

# WESTFIELD

## TRANSFER HOPPER

S08-6, S08-9, S10-6, S10-9, S13-10 / S10-6 LP, S10-9 LP, S13-10 LP  
OPERATION & ASSEMBLY MANUAL



Read this manual before using product. Failure to follow instructions and safety precautions can result in serious injury, death, or property damage. Keep manual for future reference.

Part Number: 30665 R0

Revised: Mar/10



# TABLE OF CONTENTS

<b>1. Introduction .....</b>	<b>3</b>
<b>2. Safety First.....</b>	<b>5</b>
2.1. General Safety .....	6
2.2. Assembly Safety.....	7
2.3. Operation Safety .....	7
2.4. Transport & Placement Safety .....	7
2.5. Maintenance Safety.....	8
2.6. Storage Safety.....	9
2.7. Hydraulic Safety .....	9
2.8. Tire Safety .....	10
2.9. Safety Decal Locations.....	10
2.9.1. Decal Installation .....	10
2.9.2. Decal Locations .....	10
<b>3. Assembly .....</b>	<b>13</b>
3.1. Inclined Hopper (Optional) (S08-6, S08-9, S10-6, S10-9, S13-10) .....	13
3.2. Low Profile Hopper Assembly (Optional) (S10-6, S10-9, S13-10) .....	14
3.3. Wheel Kit Assembly (Optional) (H08-4, H10-4, H13-4).....	16
3.4. Hydraulic Drive Assembly (H08-2 & H10-2) .....	17
3.5. Electric Drive Assembly (H08-3, H10-3, & H13-3 Intake Hoppers) .....	18
3.5.1. Head Drive Assembly .....	18
3.5.2. Motor Mount Assembly .....	19
3.5.3. Electric Motor Installation / Alignment .....	20
<b>4. Transport &amp; Placement .....</b>	<b>23</b>
4.1. Transport .....	23
4.2. Placement .....	23
<b>5. Operation .....</b>	<b>25</b>
5.1. Operator Controls .....	25
5.2. Drives and Lockouts .....	25
5.3. Operating Procedures .....	26
5.3.1. Break-In .....	26
5.3.2. Operation .....	27
5.3.3. Emergency Shutdown .....	28
5.3.4. Restarting With a Full Tube .....	28
5.3.5. Shutdown.....	29
5.3.6. Cleanout .....	29

# TABLE OF CONTENTS

<b>6. Maintenance</b> .....	<b>31</b>
6.1. Maintenance Intervals .....	31
6.2. Maintenance Procedures.....	31
6.2.1. Visual Inspection.....	31
6.2.2. Grease Machine .....	32
6.2.3. Clean Machine.....	33
6.2.4. Inspect Hydraulic Hose and Coupler .....	33
6.2.5. Replacing Belts (Electric Drives) .....	33
6.2.6. Tightening Belts (Electric Drives).....	34
<b>7. Storage</b> .....	<b>35</b>
<b>8. Troubleshooting</b> .....	<b>37</b>
Warranty.....	39

# 1. Introduction

Congratulations. As the new owner of a Westfield Transfer Hopper, you will be working with equipment especially designed to complement and improve your farming operation. Please read this manual to familiarize yourself with the various features of the machine, and the necessary precautions for efficient and safe operation. Anyone else who will be using this auger should also be familiar with all safety precautions. A sign-off form is supplied on the inside cover for your convenience and permanent records.

Keep this manual handy for frequent reference and to review with new personnel. Call your Westfield distributor or dealer if you need assistance, information, or additional copies of the manual.

<b>Serial Number:</b>	
*Serial number is located at top of tube.	



Equipment is available in various combinations. In most cases, the following instructions will apply to all machines. Where the assembly information varies, additional instructions will be included and will be indicated with an arrow.



## 2. Safety First



The Safety Alert symbol to the left identifies important safety messages on the product and in the manual. When you see this symbol, be alert to the possibility of personal injury or death. Follow the instructions in the safety messages. Why is SAFETY important to you?

Three big reasons:

- Accidents disable and kill.
- Accidents cost.
- Accidents can be avoided.

### SIGNAL WORDS

Note the use of the signal words **DANGER**, **WARNING**, **CAUTION**, and **NOTICE** with the safety messages. The appropriate signal word for each message has been selected using the definitions below as a guideline.

The Safety Alert symbol means ATTENTION, BE ALERT!, YOUR SAFETY IS INVOLVED.

<b>DANGER</b>	
	Indicates an imminently hazardous situation that, if not avoided, will result in serious injury or death.

<b>WARNING</b>	
	Indicates a hazardous situation that, if not avoided, could result in serious injury or death.

<b>CAUTION</b>	
	Indicates a hazardous situation that, if not avoided, may result in minor or moderate injury.

<b>NOTICE</b>	
	Indicates a potentially hazardous situation that, if not avoided, may result in property damage.

## 2.1. GENERAL SAFETY

**Important:** *The general safety section includes instructions that apply to all safety practices. Any instructions specific to a certain safety practice (e.g., assembly safety), can be found in the appropriate section. Always read the complete instructional sections and not just these safety summaries before doing anything with the equipment.*

**YOU** are responsible for the **SAFE** use and maintenance of your equipment. **YOU** must ensure that you and anyone else who is going to work around the equipment understands all procedures and related **SAFETY** information contained in this manual.

Remember, **YOU** are the key to safety. Good safety practices not only protect you, but also the people around you. Make these practices a working part of your safety program.

- It is the equipment owner and the operator's responsibility to read and understand **ALL** safety instructions, safety decals, and manuals and follow them before assembling, operating, or maintaining the equipment. All accidents can be avoided.
- Equipment owners must give instructions and review the information initially and annually with all personnel before allowing them to operate this product. Untrained users/operators expose themselves and bystanders to possible serious injury or death.
- Use this equipment for its intended purposes only.
- Do not modify the equipment in any way. Unauthorized modification may impair the function and/or safety, and could affect the life of the equipment. Any modification to the equipment voids the warranty.
- Do not allow children, spectators, or bystanders within the work area.
- Have a first-aid kit available for use should the need arise, and know how to use it.
- Provide a fire extinguisher for use in case of an accident. Store in a highly visible place.
- Wear appropriate protective gear. This list includes, but is not limited to:
  - a hard hat
  - gloves
  - protective shoes with slip-resistant soles
  - protective goggles
  - hearing protection
- For Powered Equipment: before servicing, adjusting, or repairing powered equipment, unplug, place all controls in neutral or off position, stop the engine or motor, remove ignition key or lock out power source, and wait for all moving parts to stop.



- Follow good shop practices:
  - keep service area clean and dry
  - be sure electrical outlets and tools are properly grounded
  - use adequate light for the job at hand
  - Think SAFETY! Work SAFELY!



## 2.2. ASSEMBLY SAFETY

---

- Read the instructions and familiarize yourself with the subassemblies and hardware making up the equipment.
- The components are large, heavy, and can be hard to handle. Be sure to use the proper tools, stands, jacks, and hoists for the job.
- Have 2 people handle the heavy bulky components.
- Place safety stands or large blocks under the machine or components before going beneath the component for assembly.
- Stay away from overhead power lines and obstructions when lifting the machine during assembly. Electrocutation can occur without direct contact. Contact with obstructions can damage components or cause them to fail.
- Tighten all fasteners to their specified torque before using the machine.

## 2.3. OPERATION SAFETY

---

- Have another person nearby who can shut down the equipment in case of accident.
- Do not operate with any of the safety guards removed.
- Keep body, hair, and clothing away from moving parts. Stay away from intake during operation.

## 2.4. TRANSPORT & PLACEMENT SAFETY

---

- Check with local authorities regarding transport on public roads. Obey all applicable laws and regulations.
- Always travel at a safe speed. Use caution when turning corners or meeting traffic.
- Use extreme care and minimum ground speed when operating or transporting on hillsides, over rough ground, or near ditches or fences.
- Review the work safety area diagram before starting work.

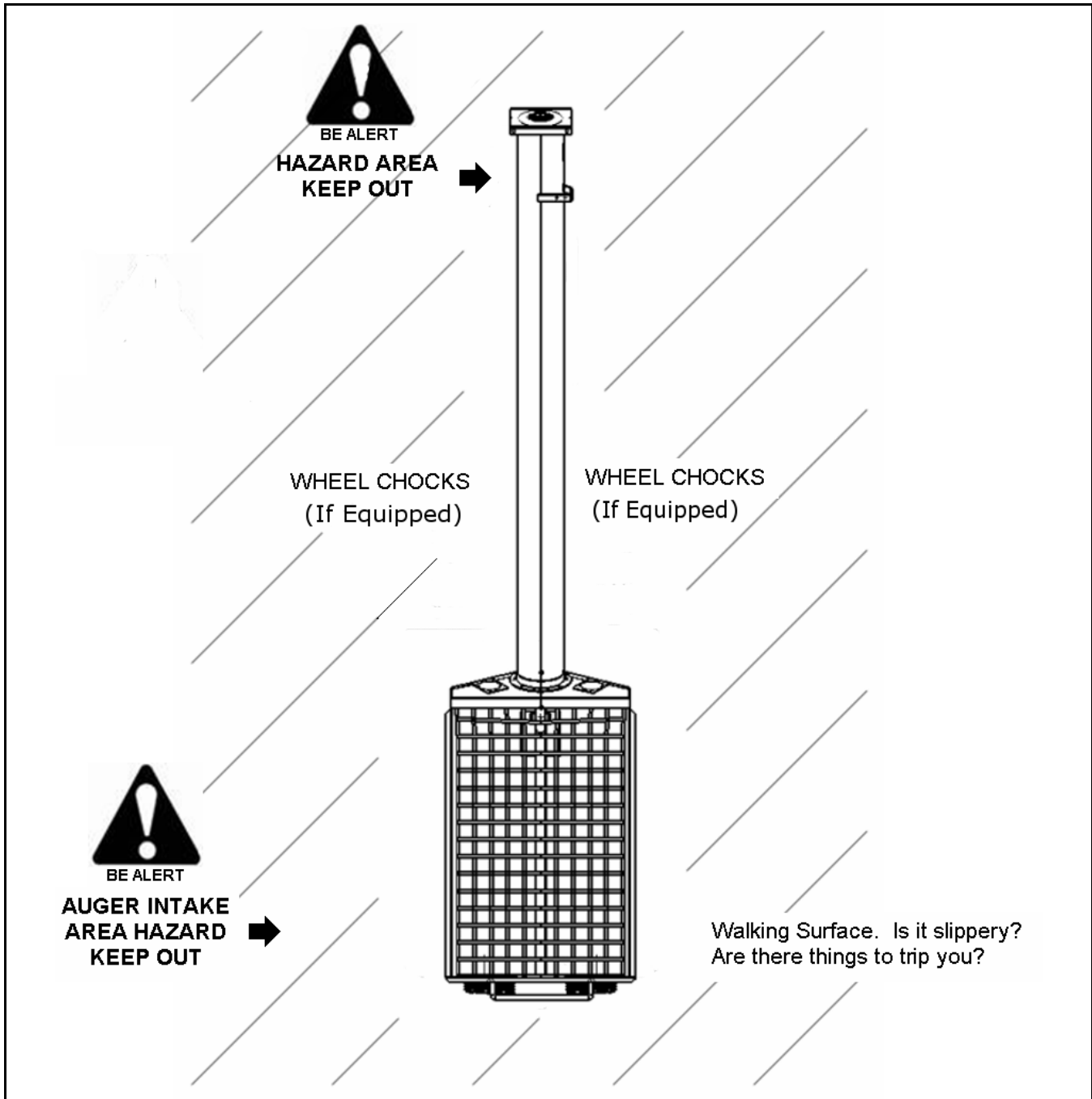

Figure 2.1 Work Area - Authorized Personnel Only

## 2.5. MAINTENANCE SAFETY

- Place stands or blocks under the frame before working beneath the machine.
- After maintenance is complete, replace and secure all safety guards and safety devices, and if applicable, service doors and cleanout covers.

- Remove all tools and unused parts from machine before operation.
- Remove buildup of grease, oil, and debris.
- Inspect all parts. Ensure parts are in good condition and installed properly.
- Use extra caution when cleaning and servicing auger because flighting edges can be sharp.

*Use only genuine Westfield replacement parts or equivalent. Replacement parts must meet ASAE standards or serious injury may result. Use of unauthorized parts will void the warranty. If in doubt, contact Westfield or your Westfield dealer.*

## 2.6. STORAGE SAFETY

---

- Store in an area away from human activity.
- Do not permit children to play on or around the stored machine.

## 2.7. HYDRAULIC SAFETY

---

- Always place all hydraulic controls in neutral and relieve system pressure before disconnecting or working on hydraulic system.
- Keep all components in the hydraulic system tightly secured and in good condition and clean.
- Replace any worn, cut, abraded, flattened, or crimped hoses.
- Do not attempt any makeshift repairs to the hydraulic fittings or hoses with tape, clamps, or concrete. The hydraulic system operates under extremely high pressure; such repairs will fail suddenly and create a hazardous and unsafe condition..

<b>WARNING</b>	
	<p>Hydraulic fluid can cause serious injury if it penetrates the skin. If it does, see a doctor immediately.</p> <ul style="list-style-type: none"><li>• Relieve pressure before disconnecting hydraulic line.</li><li>• Wear proper hand and eye protection and use wood, or cardboard, not hands when searching for leaks.</li></ul>

## 2.8. TIRE SAFETY

---

- When replacing worn tires, ensure that they meet the original tire specifications. Never undersize the replacement tire.
- Let a qualified tire repair shop perform all required tire replacements.
- Ensure that the tires are inflated to the manufacturers's recommended pressure.

## 2.9. SAFETY DECAL LOCATIONS

---

- Keep safety decals clean and legible at all times.
- Replace safety decals that are missing or have become illegible. See decal location figures below.
- Replaced parts must display the same decal(s) as the original part.
- Safety decals are available from your distributor, dealer, or factory.

### 2.9.1. DECAL INSTALLATION

---

1. Decal area must be clean and dry, with a temperature above 10°C (50°F).
2. Decide on the exact position before you remove the backing paper.
3. Align the decal over the specified area and carefully press the small portion with the exposed sticky backing in place.
4. Slowly peel back the remaining paper and carefully smooth the remaining portion of the decal in place.
5. Small air pockets can be pierced with a pin and smoothed out using the sign backing paper.

### 2.9.2. DECAL LOCATIONS

---

Replicas of the safety decals that are attached to the equipment are shown in the figure(s) that follow. Good safety requires that you familiarize yourself with the various safety decals and the areas or particular functions that the decals apply to as well as the safety precautions that must be taken to avoid serious, injury, death, or damage.

*\* Westfield reserves the right to update safety decals without notice. Safety decals may not be exactly as shown.*

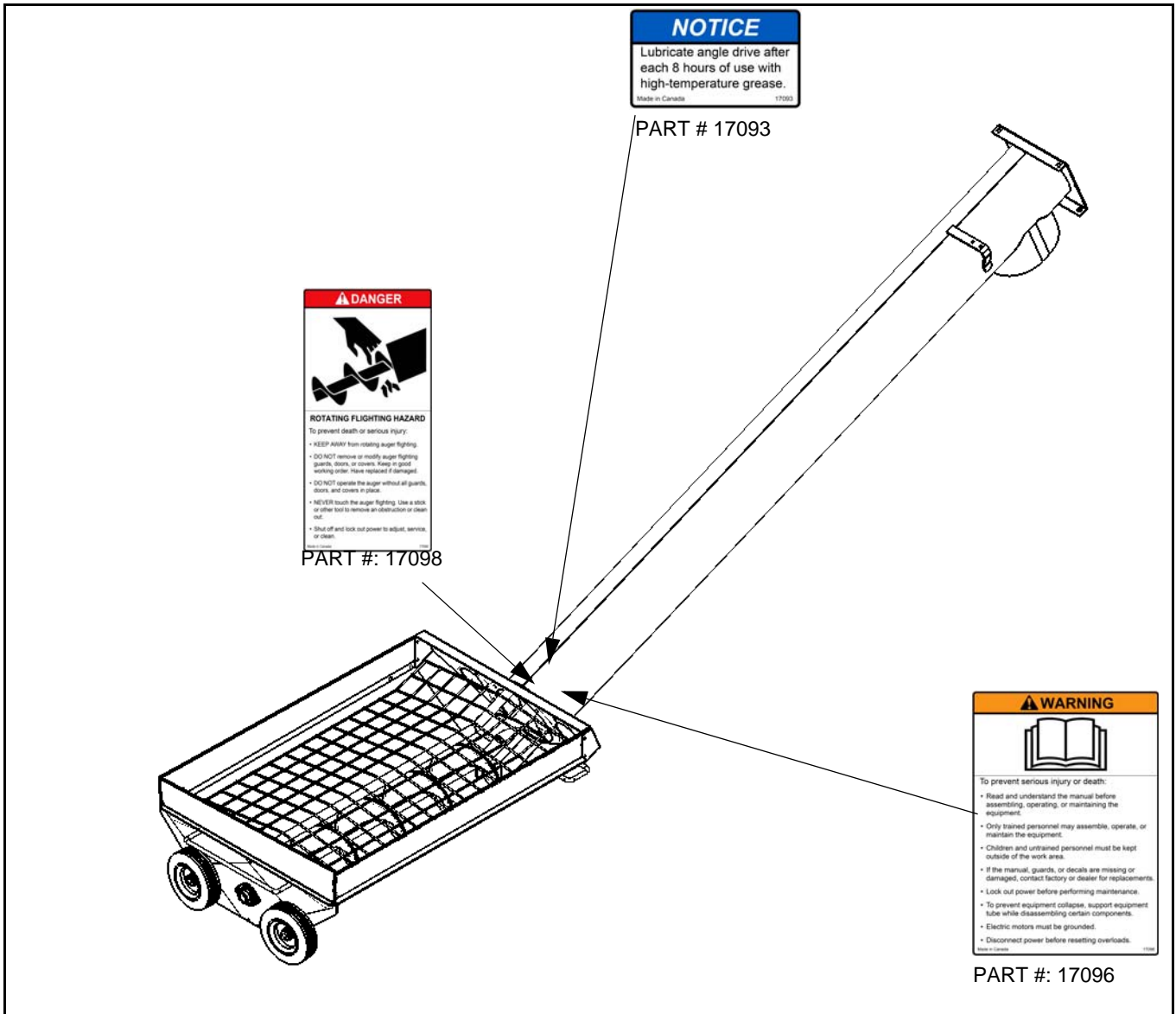

Figure 2.2 Safety Decals Inclined Hopper

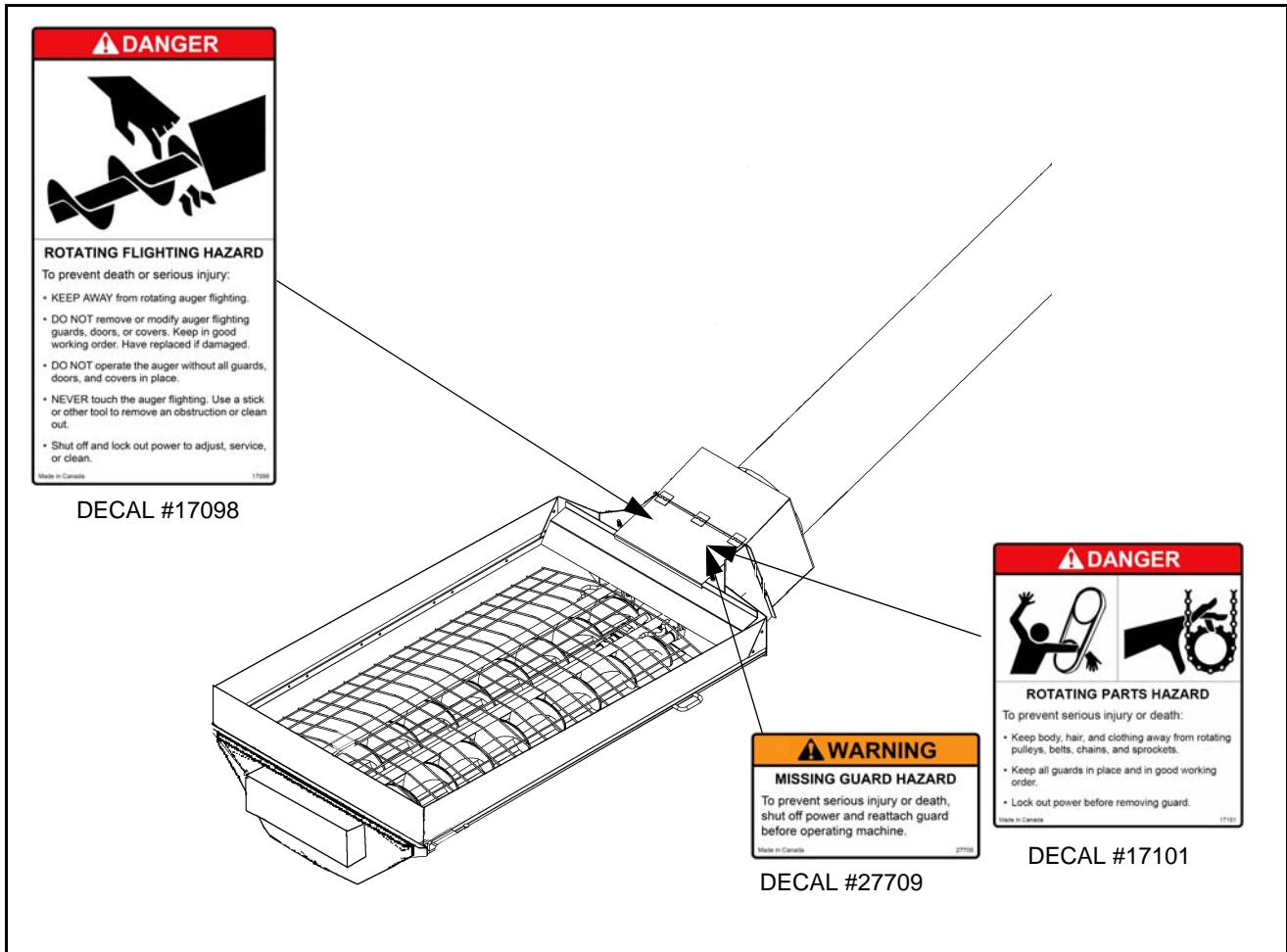

Figure 2.3 Safety Decals Low Profile Hopper

# 3. Assembly

**Warning:** Before continuing, please reread the safety information relevant to this section at the beginning of this manual. Failure to follow the safety instructions can result in serious injury, death, or property damage.

## 3.1. INCLINED HOPPER (OPTIONAL) (S08-6, S08-9, S10-6, S10-9, S13-10)

1. Remove access covers and clean paint and dirt from flightshaft end. Insert Woodruff key as shown in Figure 3.1.
2. Raise tube to correct angle<sup>1</sup>, then bring hopper and tube sections together, carefully sliding the flightshaft end with Woodruff key into the angle drive. Connect the hopper and tube section with eight 7/16" x 1" bolts (for the **8" & 10" models**) and locknuts. **13" Models** use 12 bolts and locknuts. See Figure 3.1. **Reinstall access covers.**

### NOTICE

To prevent damage, you must maintain the correct angle when inserting flightshaft end into angle drive until tube is secured to the hopper section. Allowing tube or hopper to drop will bend the flightshaft end, causing it to bind in the angle drive.

3. Thoroughly lubricate the angle drive and keep it well lubricated.

**Note:** *After connecting the hopper and tube sections, check whether the angle drive is properly aligned. You should be able to rotate the hopper flight by hand if the angle drive is aligned.*

4. Clean wheel axles on hopper bottom of any paint and dirt.

---

<sup>1</sup>.Correct angle is achieved when the flight shaft end is inserted in the angle drive and its weight is fully supported by the block and stand.

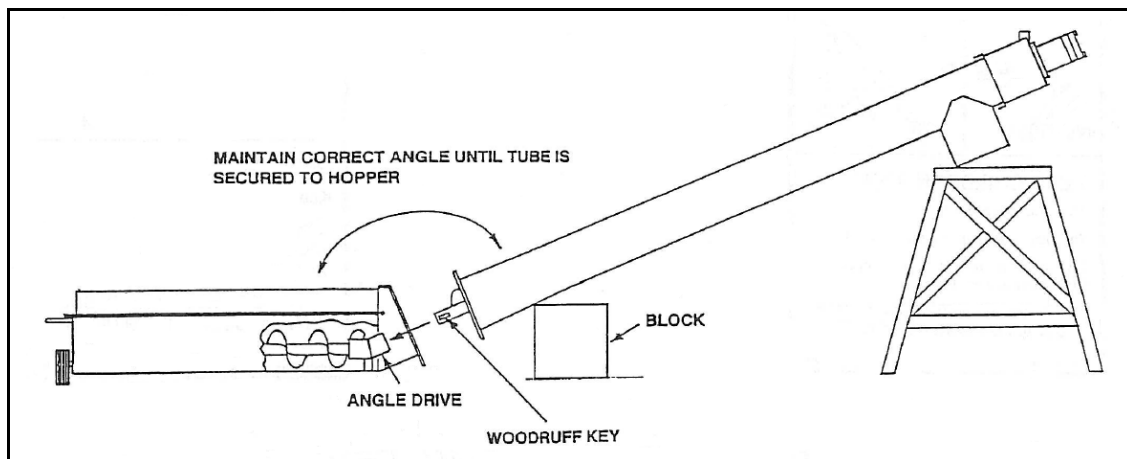

Figure 3.1

5. Install the 2 wheels to hopper with a washer and cotter pin. The washer should be between wheel and cotter pin (Figure 3.2).
- ➔ 6. **8" & 10" Only:** Install rubber extension on inside hopper lip with twenty 5/16" x 3/4" bolts and washer locknuts, and 8 long and 2 short flat iron straps (Figure 3.2).
- ➔ 7. **13" Only:** Install the 2-piece rubber extension on inside hopper lip with twenty-eight 5/16" x 3/4" bolts and washer locknuts, ten long and two short flat iron straps. (Figure 3.2)

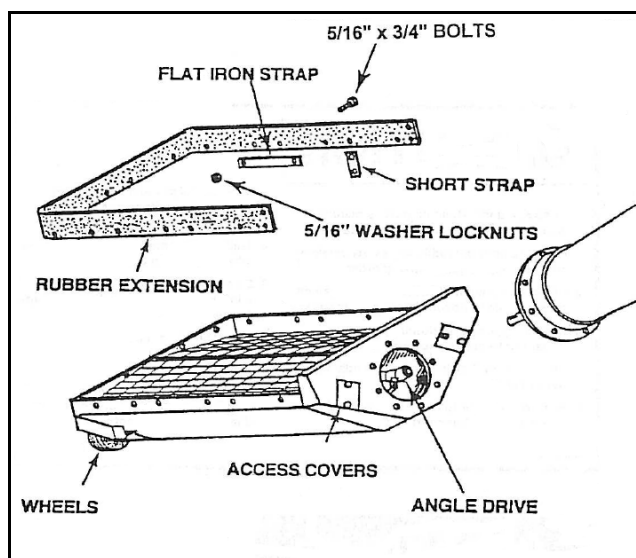

Figure 3.2

## 3.2. LOW PROFILE HOPPER ASSEMBLY (OPTIONAL) (S10-6, S10-9, S13-10)

See Figure 3.3–3.4

1. Attach the pivot-connector to the appropriate holes in hopper with two 5/8" x 1-1/2" bolts and locknuts. **Do not over-tighten.** Tighten snug only; these bolts act as pivot points.
2. Loosely secure the service door with the 2 square latch-washers and 3/8" locknuts.

**Note:** *These must be tightened securely after hopper assembly is completed.*

3. Clean dirt from inside u-joint and flight shaft end, then insert Woodruff key.
4. Raise and support hopper tube at about 50" under spout.
5. Open service door on hopper, then bring tube and hopper together guiding flight shaft into u-joint.
6. Secure tube to pivot-connector on hopper using 7/16" x 1" bolts and locknuts.

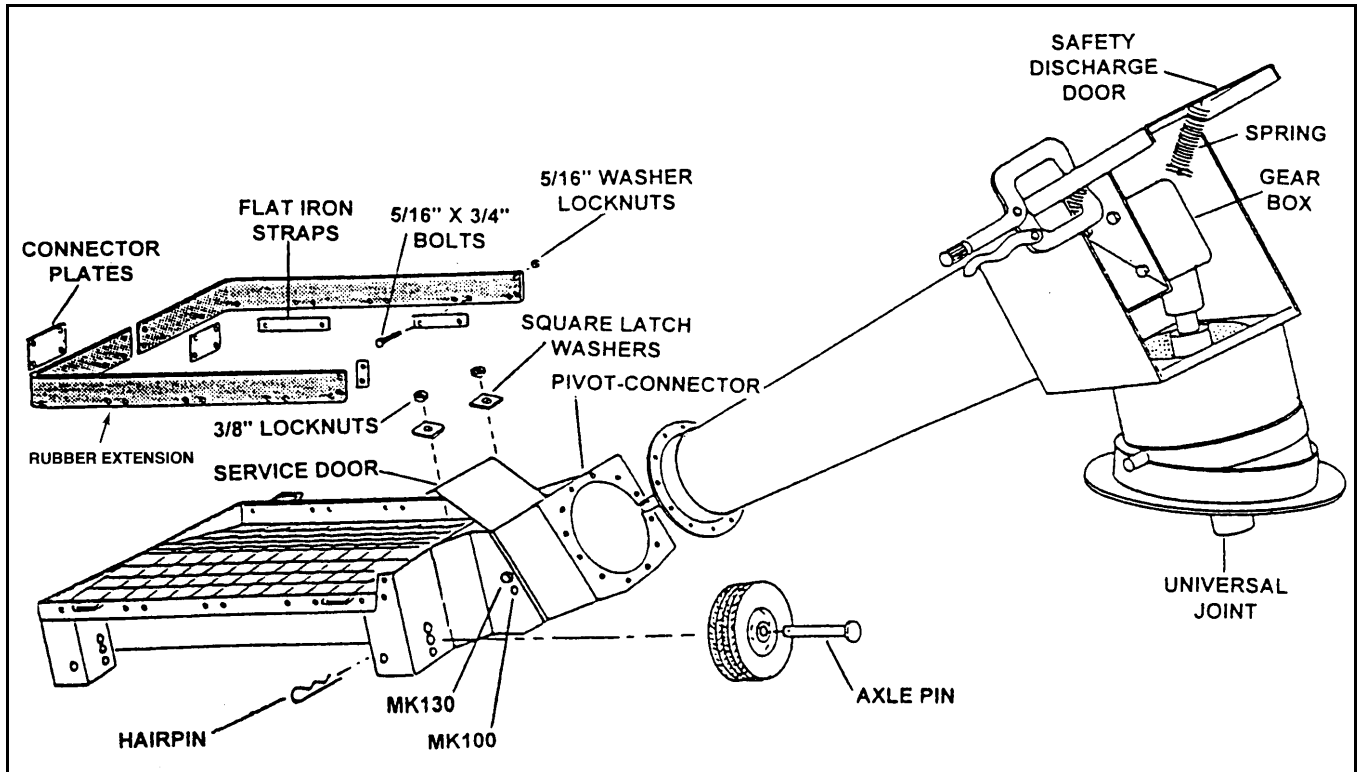

Figure 3.3

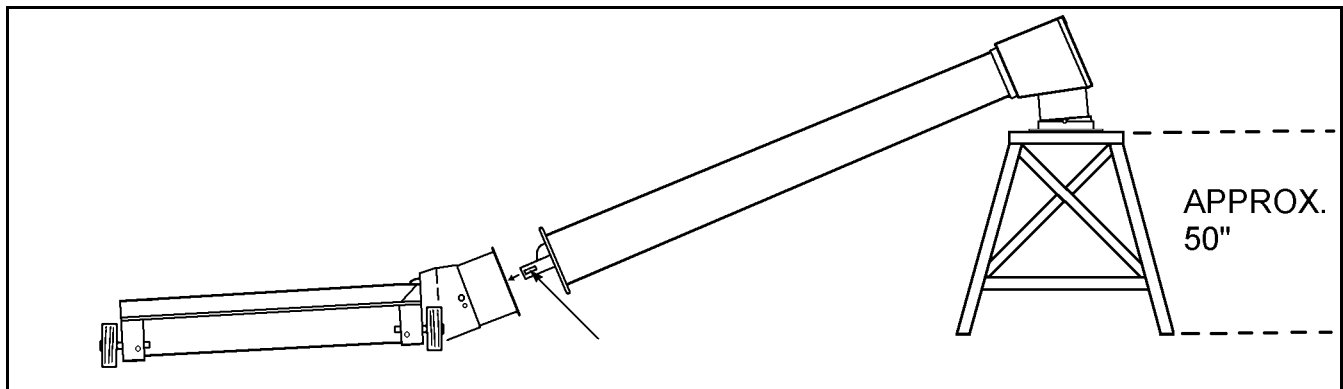

Figure 3.4

7. Tighten set screws on u-joints, then close and secure the service door.

8. Remove the two 5/16" washer locknuts that secure the chain drive guard. Attach the 2-piece rubber extension to inside of hopper lip with 5/16" x 3/4" bolts and washer locknuts and the flat iron straps provided, plus the 2-piece extension connector plates.
9. Attach the 4 pneumatic wheels to the 4 hopper corners with the axle pins and hairpins. The offset portion of the wheel must rest against the hopper.
  - You have a choice of 3 height settings.

### 3.3. WHEEL KIT ASSEMBLY (OPTIONAL) (H08-4, H10-4, H13-4)

**Note:** Do not tighten bolts until step 6.

1. Attach the 2 braces to inside of each lug on the axle using two 7/16" x 1" bolts and locknuts (see Figure 3.5).

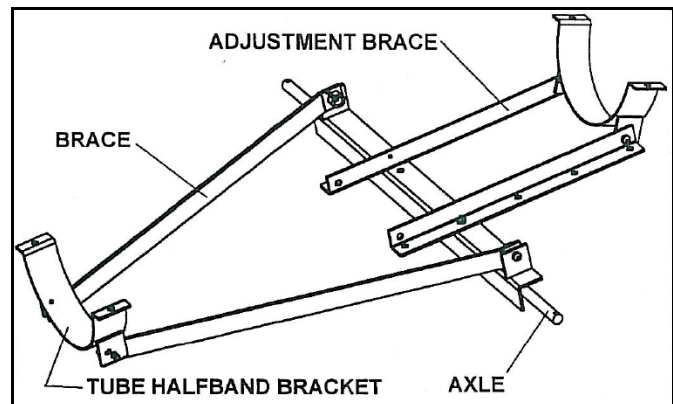

Figure 3.5

- ➔ 2. Mount adjustment braces on top of axle with two 7/16" x 1" bolts and locknuts. Use the set of holes in adjustment braces best suited for desired tube angle. **8" tube:** inner set of holes on axles, **10" tube:** middle set, and **13" tube:** outer set. Mount tube halfband bracket to adjustment braces as shown (see Figure 3.5) with two 7/16" x 1" bolts and locknuts.

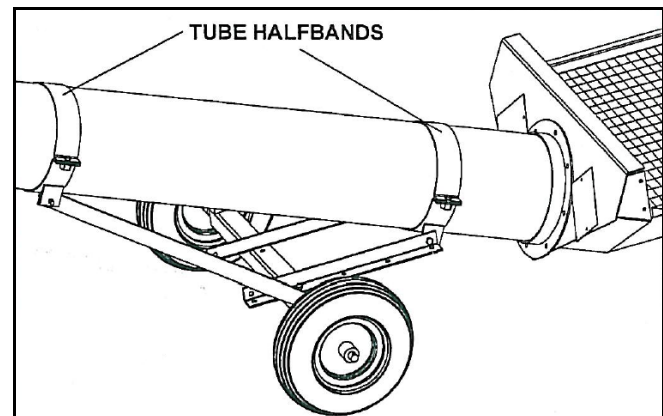

Figure 3.6

3. Mount second tube halfband bracket to braces with two 7/16" x 1" bolts and locknuts.
4. Remove dirt and paint from axle stubs then slip wheels onto axle stubs and secure with cotter pins.

5. Now place the hopper tube in the halfband brackets and secure with 2 halfbands and four 7/16" x 1" bolts and locknuts, but do not tighten (see Figure 3.6).
6. Adjust braces and tube halfbands as needed to achieve desired weight balance and tube height. Maintain enough weight at intake to prevent upending. Tighten all bolts and this stage.

### 3.4. HYDRAULIC DRIVE ASSEMBLY (H08-2 & H10-2)

The hydraulic motor drive for the intake feed hopper is partially pre-assembled. This assembly includes the motor mount, the hydraulic motor, and the chain connector. To complete assembly:

1. Remove chain connector (with 1 sprocket) from motor mount assembly (Figure 3.7). Clean paint and dirt from flight stub and inside sprocket hub.

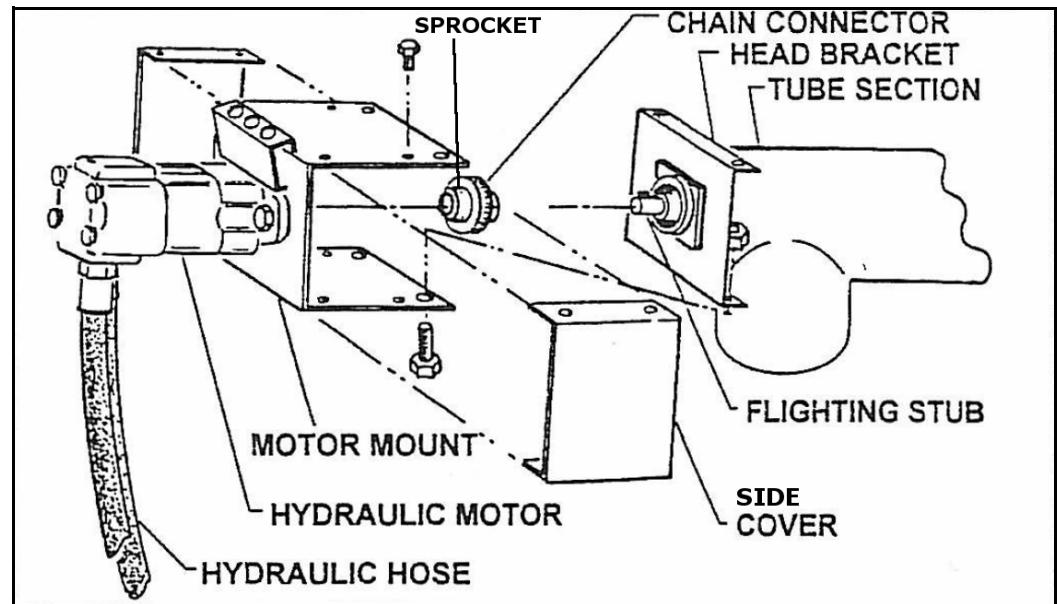

**Figure 3.7**

2. Slide connector sprocket onto flighting stub with a 1/4" x 1-1/2" square key.
3. Place the hydraulic motor mount assembly with ports down to the head bracket on the tube section, and attach four 1/2" x 1-3/4" bolts and locknuts.
4. Re-install chain on connector sprockets making sure to keep clearance of approximately 1/16." Tighten set screws.
5. Attach the 2 side covers with four 1/4" x 1/2" bolts.
6. Securely attach 2 hydraulic hoses to the hydraulic motor. Use 1/2" hoses and 7/8" ORB thread with a rating of 2500 psi (not supplied).

- Before connecting the auger hydraulic hoses to the tractor, ensure that all safety precautions and correct operational procedures are fully understood. Ensure that the quick connect couplers on tractor are clean and free of dirt by wiping them with a clean cloth.

**Important:** *Dirt in the hydraulic system can damage the hydraulic motor, causing possible failure.*

- After connecting the hoses, visually check them for leaks, binding, flattening, kinks, or wear.

<b>CAUTION</b>	
	To prevent injury do not disconnect hydraulic coupler when system is pressurized.

## 3.5. ELECTRIC DRIVE ASSEMBLY (H08-3, H10-3, & H13-3 INTAKE HOPPERS)

---

### 3.5.1. HEAD DRIVE ASSEMBLY

---

- Remove dirt and paint from upper end of flight shaft.
- Install the Woodruff key provided (or a square key) and slide the larger pulley onto the flight shaft with the hub facing away from the auger. **DO NOT** tighten set screws at this time (see Table 3.1 for proper pulley size).

**Table 3.1 Pulley Sizes & Combinations**

Auger Size	RECOMMENDED SIZES		
	Auger Pulley	Motor Pulley	Flight Speed (RPM) <sup>a</sup>
8" Hopper	12.7"	3-1/4"	440
	12.7"	3-1/2"	475
10" Hopper	15"	3-1/4"	375
	15"	3-1/2"	402
13" Hopper	16"	3-1/4"	350
	16"	3-1/2"	378

To determine flight speed (rpm):<sup>b</sup>  
 Divide the speed (rpm) of the motor by the outside diameter of the large auger pulley, then multiply by the outside diameter of the small motor pulley:  $1725 \text{ (rpm)} = 15" \times 3.5" = 402 \text{ rpm}$

- a. Speed is calculated using a 1725 rpm electric motor.
- b. If a slower flight speed is desired, install a smaller motor pulley.

### 3.5.2. MOTOR MOUNT ASSEMBLY

1. Attach front mount plate onto head plate using two 1/2" x 1-1/2" bolts, locknuts, and 1/2" flat washers as shown in Figure 3.8. Tighten securely.
2. Place 5/8" adjust bolt through available hole in front mount plate and secure in place using two 5/8" hex nuts (1 top, 1 bottom). Leave adjust bolt loose to allow for later adjustment (Figure 3.8).

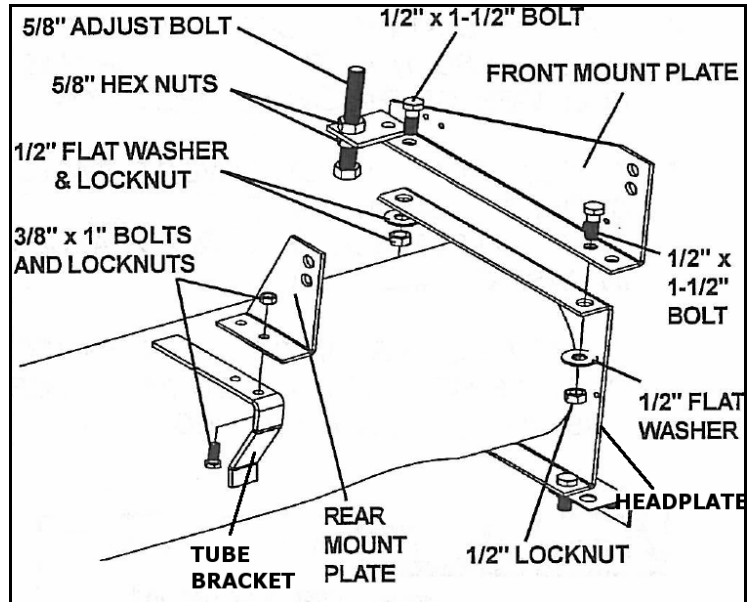

Figure 3.8

**Note:** The 5/8" nuts and adjust bolt are used to adjust belt tension.

3. Assemble rear mount plate onto tube bracket as shown in Figure 3.8 with two 3/8" x 1" bolts and locknuts; tighten securely.
4. Place motor mount assembly in between the 2 mount plates and insert hinge rod as shown in Figure 3.9. Secure hinge rod with a 1/8" x 1-1/2" cotter pin.

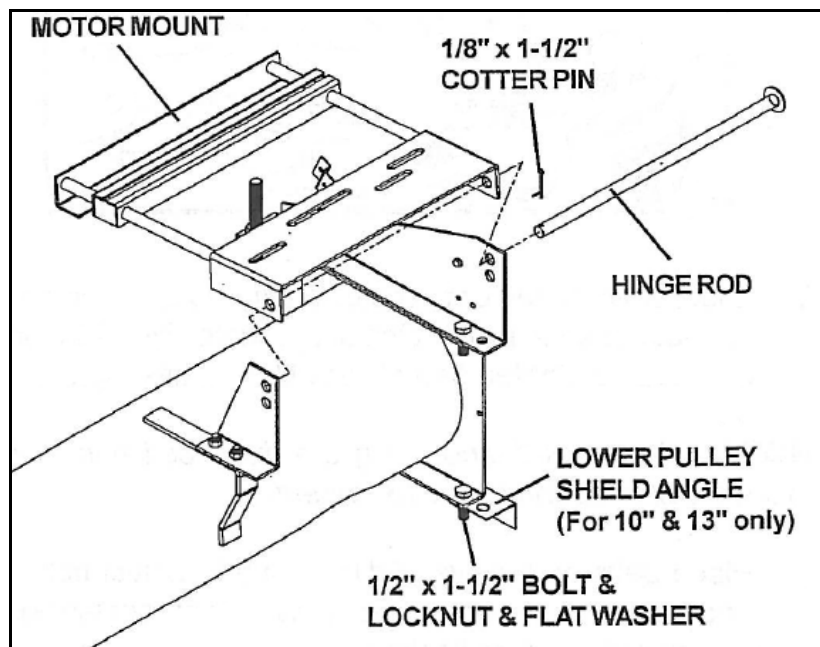

Figure 3.9

- ➡ 5. **For 10" and 13"** augers, attach lower pulley shield angle to the head plate with two 1/2" X 1-1/2" bolts and locknuts and 1/2" flat washers (Figure 3.9). Tighten securely.

### 3.5.3. ELECTRIC MOTOR INSTALLATION / ALIGNMENT

---

1. Place electric motor (see Table 3.2 for proper horsepower requirements) onto motor mount and secure. Ensure that motor shaft is parallel to and centered on discharge tube before tightening adjust bolt.

**Note:** *We recommend using the 3 belt and triple groove pulley option on all 13" augers.*

#### When using an electric motor:

- The motor and controls should be installed by a qualified electrician in accordance with all local and national codes.
- Incorporate a magnetic starter to protect the motor.
- The motor must have a manual reset button.
- Locate reset and starter controls so that the operator has full view of the entire operation.
- Locate main power disconnect switch within reach from ground level to permit ready access in case of an emergency.
- A main power disconnect switch capable of being locked (in the off position only) must be provided.

2. Slide drive pulley onto motor shaft (see Table 3.1 for suggested sizes). Insert the appropriate square key. Do not tighten set screw until belts are aligned (after Step 4.)

**Note:** 3. Place belts on pulleys. Adjust the 5/8" adjust bolt on front mount plate until the belts have the proper tension with about a 1/8" deflection.

**Table 3.2 Horsepower Requirements**

Hopper	Horsepower (HP) <sup>a</sup>
8" Hopper	3-5
10" Hopper	5-7
10" Hopper LP	5-7
13" Hopper	10-15
13" Hopper LP	10-15

a. Approximate electric motor horsepower requirements under normal conditions. When augering full tube of high moisture grain, additional horsepower will be needed.

**Note:** *The correct operating tension is the lowest tension at which the belts will not slip under peak load conditions.*

4. Align the two pulleys (use a straight edge). Once belts are aligned and under tension, lock the 5/8" hex nuts and tighten pulley set screws.

**Important:** *Once all bolts and set screws are tightened, re-check alignment. Proper alignment will prolong belt life.*

➔ 5. **For 8" systems**, assemble the adjustable two-piece pulley shield with two 1/4" x 1/2" bolts and washer locknuts.

➔ 6. **For 10" and 13" systems**, assemble the adjustable three-piece pulley shield with four 1/4" x 1/2" bolts and washer locknuts (see Figure 3.10).

**Note:** *A shield extension is required on all powerheads using a 15" pulley.*

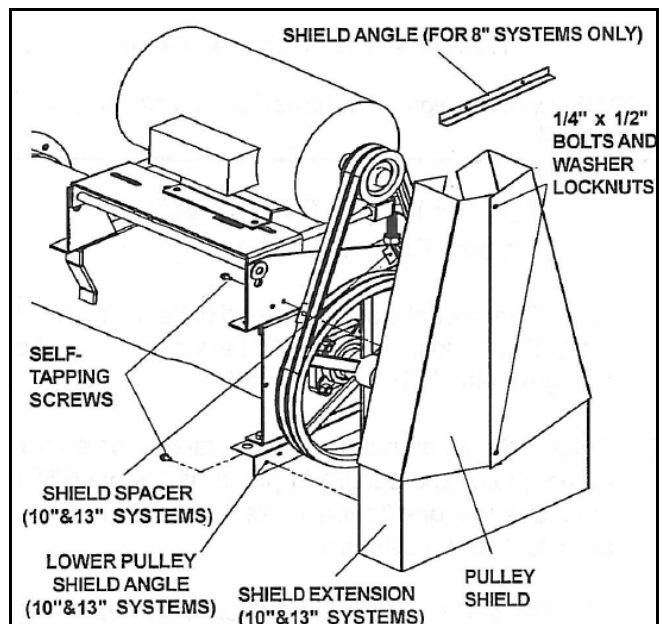

**Figure 3.10**

- ➡ 7. **For 8"** systems, attach the pulley shield to the front mount plate and the end plate with 4 self-tapping screws. The shield is attached to front mount plate using a single shield angle attached with self-tapping screws.
- ➡ 8. **For 10" and 13"** systems, attach the pulley shield to the lower pulley shield angle and the end plate with 4 self-tapping screws. The shield is mounted to the end plate using 2 shield spacers attached with self-tapping screws (Figure 3.10).

# 4. Transport & Placement

**Warning:** Before continuing, please reread the safety information relevant to this section at the beginning of this manual. Failure to follow the safety instructions can result in serious injury, death, or property damage.

## 4.1. TRANSPORT

---

1. When moving the transfer auger from location to location, place the unit on a transport vehicle and tie down securely. DO NOT tow behind a vehicle.

### NOTICE

DO NOT tow transfer auger behind a vehicle. Wheels are not rated for road use and serious damage to the equipment could occur.

## 4.2. PLACEMENT

---

When placing the auger, follow these guidelines:

- Ensure there is enough clearance from other equipment to move the machine into its working position.
- Move the machine under the truck or storage facility.
- Place the auger on a firm, level surface.
- Chock the wheels before augering any products.

**Note:** *The machine is almost evenly balanced. Pushing down a little on the discharge end will raise the intake end off the ground and allow easy maneuvering.*



# 5. Operation

**Warning:** Before continuing, please reread the safety information relevant to this section at the beginning of this manual. Failure to follow the safety instructions can result in serious injury, death, or property damage.

## 5.1. OPERATOR CONTROLS

---

Please refer to engine manual for engine controls.

## 5.2. DRIVES AND LOCKOUTS

---

Correct operation of this unit requires pre-inspection of the drive system, operator knowledge on how to shut down the system, and a general monitoring of the system during operation.

### ➡ **Electric Motor**

Before starting the motor, ensure that:

#### DRIVE SYSTEM

- The motor is properly grounded.
- All electrical connections/wiring have been performed by a licensed electrician.
- Pulley guards are in place and secure.

#### LOCKOUT

- The electric motor is equipped with a main power disconnect switch capable of being locked in the “off” position only. Lock the switch in the “off” position during shutdown or when maintenance is performed on the auger.
- If reset is required, disconnect all power before resetting motor.

### ➡ **Hydraulic Motor**

Before starting the motor, ensure that:

#### DRIVE SYSTEM

- Hoses are not leaking and are free of cracks.
- Hose connections are free of dirt and debris.

#### LOCKOUT

- Shut down power source and disconnect hydraulic hoses from power source.

WARNING	
	<p>Hydraulic fluid can cause serious injury if it penetrates the skin. If it does, see a doctor immediately.</p> <ul style="list-style-type: none"><li>• Relieve pressure before disconnecting the hydraulic line.</li><li>• Wear proper hand and eye protection and use wood or cardboard, not hands, when searching for leaks.</li></ul>

## 5.3. OPERATING PROCEDURES

---

### 5.3.1. BREAK-IN

---

Your auger does not require an elaborate break-in. However, following a few simple tips during the first 15 minutes of operation can add to the reliability and life of your machine.

The angle drive will require a break-in period of at least 2 to 3 loads.

**Note:** *If the angle drive in hopper runs hot after an appropriate break-in period, this may mean the angle drive is not properly aligned. To correct, first lock out power, then loosen bolts securing the angle drive, and adjust or shim up until the flight can be more easily rotated by hand.*

Prior to operating make sure to read the power source operation manual.

During the break-in period:

- Inspect motor mounting bolts for tightness.
- ➔
- **Electric Drives:** Inspect all belts for alignment, tightness, and abnormal wear. Adjust or replace as required.
  - Inspect components for damage and abnormal wear. Replace as required.
  - Check that safety decals are installed and legible. Apply new decals if required.
- ➔
- **Low Profile Hopper:** Check chain drive tension and alignment, apply or adjust grease.

Please refer to “Maintenance Procedures” on page 31 for recommended service intervals after the break-in period.

## 5.3.2. OPERATION

---

### PRE-OPERATION CHECKLIST

Check the following items before operating the machine **each time**:

- All guards are in place, and secure.
- ➔ • **ELECTRIC DRIVES:** Drive belts are not frayed or damaged, and are properly tightened and aligned.
- Discharge spout and intake area are free of obstructions.

### NORMAL START-UP

- ➔ 1. **Hydraulic Drives:** Ensure that the quick connect couplers on tractor are clean and free of dirt by wiping them with a clean cloth.

**Important:** *Dirt in the hydraulic system can damage the hydraulic motor, causing possible failure.*

- 2. Start the power source.

- ➔ 3. **Hydraulic Drives:** Increase the augering speed to achieve the desired speed.

**Note:** *The flighting rpm on augers equipped with **electric motors** is not adjustable.*

- 4. If everything is operating normally, start running grain through the auger.

If any unusual noises or vibrations are encountered, determine the source, shut the auger off, lock out the power source, and adjust. If unsure of the problem, or the procedure to fix it, contact your local Westfield dealer.

### NOTICE

Foreign objects can damage the auger.

Lock out power and remove any obstructions from the intake and discharge areas before operating the unit.

<b>DANGER</b>	
	<p>Contact with rotating flighting will result in amputation or severe laceration.</p> <ul style="list-style-type: none"><li>• Keep away from rotating auger flighting.</li><li>• Do not remove or modify auger flighting guards, doors, or covers. Keep in good working order. Have replaced if damaged.</li><li>• Do not operate the auger without all guards, doors and covers in place.</li><li>• Never touch the auger flighting. Use a stick or other tool to remove an obstruction or clean out.</li><li>• Shut off and lock out power to adjust, service, or clean.</li></ul>

### 5.3.3. EMERGENCY SHUTDOWN

---

Although it is recommended that the machine be emptied before stopping, in an emergency situation:

1. Stop or shut down the power source immediately.
2. Stop the flow of material (if applicable).
3. Lock out power, and correct the emergency before resuming work.

<b>WARNING</b>	
	<p>To prevent serious injury, lock out all power before attempting repairs or removing obstructions.</p>

### 5.3.4. RESTARTING WITH A FULL TUBE

---

The tube may be filled with material if the machine is shut down inadvertently or for an emergency. It is recommended that you restart with the following procedure:

1. Lock out power and remove as much of the grain as possible from the tube and intake using a piece of wood, vacuum cleaner, or other tool before restarting auger. **Do not reach in and use your hands** (see Section 5.2. Drives and Lockouts on page 25).

- ➡ 2. **Hydraulic Drive:** Increase the hydraulic flow to achieve the desired augering speed.
- ➡ 3. **Electric Drive:** Start the electric motor and run to clear the full tube.
- 4. Proceed to run grain through auger.

### 5.3.5. SHUTDOWN

---

#### NORMAL SHUTDOWN

- 1. Near the end of the load, reduce the feed of grain.
- ➡ 2. **Hydraulic Drive:** Decrease the auger speed.
- 3. Stop motor when the auger is clear of grain.
- ➡ 4. **Hydraulic Drive:** Place hydraulic lever in neutral.
- ➡ 5. **Electric Drive:** Shut down motor.
- 6. Lock out power source.

**Important:** *Prolonged operation of an empty auger will cause unnecessary wear.*

### 5.3.6. CLEANOUT

---

- 1. Run the unit to clean out the majority of the grain.
- 2. Shut down and lock out the power source.
- 3. Clean grain from the auger and hopper, and dump it into a container.

**Note:** *Transfer can be tipped sideways to assist in fully cleaning unit.*



# 6. Maintenance

**Warning:** Before continuing, please reread the safety information relevant to this section at the beginning of this manual. Failure to follow the safety instructions can result in serious injury, death, or property damage.

This unit has been designed and manufactured to meet the highest standards while requiring minimal maintenance. Following a careful service and maintenance program will provide many years of trouble-free service.

## 6.1. MAINTENANCE INTERVALS

Refer to Section 6.2., for details of service.

**Table 6.1**

Maintenance Procedure	Time Period		
	Daily (8000 BU)	Periodically (40,000 BU)	Annually (Before Storage)
Visually inspect the unit.	√	-	-
Grease machine.	-	√	-
Clean machine.	-	-	√
Service belts (Electric Models Only).	-	√	-

## 6.2. MAINTENANCE PROCEDURES

### 6.2.1. VISUAL INSPECTION

Before beginning the visual inspection, chock auger wheels and ensure that all operators are aware of safety precautions. When inspecting:

- Lubricate the angle drive after every 8 hours of operation. Use high-temperature grease.
- Ensure all guards are in place, and in good working order.
- Examine the auger for damage or unusual wear.
- **Hydraulic Models:** Examine hydraulic hoses and fittings for leaks and cracks.





- Be sure all safety decals are in place and are legible.
- **Electric Drive Models:** Check that drive belts are not frayed or damaged. Ensure they are properly adjusted and aligned.
- Check that the discharge spout and intake area are free of obstructions.
- Examine all flighting for damage or unusual wear.
- Examine tires for gashes, uneven wear, or loss of air pressure.
- Inspect auger shaft bushing for unusual wear or discoloration.

## 6.2.2. GREASE MACHINE

### FLUIDS AND LUBRICANTS

#### Grease

Use SAE multi-purpose, high-temperature grease with extreme pressure (EP) performance, or SAE multi-purpose lithium-based grease.

#### Storage and Handling

Always follow manufacturer's guidelines for safe and effective storage and handling of lubricants.

Your machine can operate at top efficiency only if clean lubricants are used. Use clean containers to handle all lubricants. Store them in an area protected from dust, moisture, and other contaminants.

**Note:** *Original flange bearings used by Westfield are sealed units and will not accept grease. (S08-6 and S08-9 Models Only)*

1. Lock out all power.
2. Wipe grease fitting with a clean cloth before greasing to avoid injecting dirt and grit.
3. Using the grease recommended in Section 6.1., grease points on the machine (shown by arrows in Figure 6.1.)

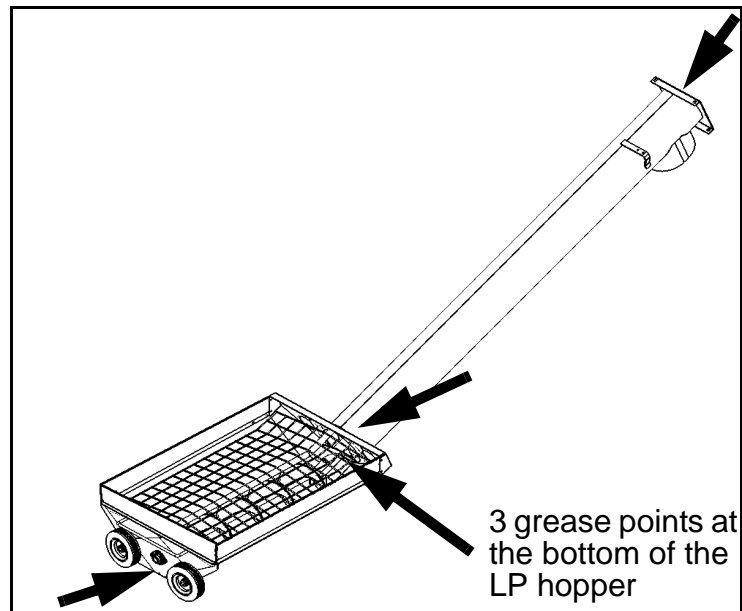

Figure 6.1

If a fitting will not take grease, remove and clean thoroughly. Also clean lubricant passageway. Replace fitting if necessary.

4. Replace or repair broken or missing fittings immediately.

### 6.2.3. CLEAN MACHINE

---

1. Lock out all power.
2. Clean out excess grain from auger tube and intake.
3. Make sure nothing is obstructing the auger intake so water can run out.
4. Wash the tube with a water hose or pressure washer until all dirt, mud, debris, or residue is washed from the auger.
5. Provide sufficient time for the water to drain from the auger.

### 6.2.4. INSPECT HYDRAULIC HOSE AND COUPLER

---

1. Pressurize the system.
2. Using a piece of cardboard or wood, run it along the length of the hose and around all fittings. Replace the hose or tighten/replace the fitting if a leak is found.

<b>WARNING</b>	
	<p>Hydraulic fluid can cause serious injury if it penetrates the skin. If it does, see a doctor immediately.</p> <ul style="list-style-type: none"><li>• Relieve pressure before disconnecting hydraulic line.</li><li>• Wear proper hand and eye protection and use wood or cardboard, not hands, when searching for leaks.</li></ul>

### 6.2.5. REPLACING BELTS (ELECTRIC DRIVES)

---

1. Lock out all power.
2. Remove guard to allow access to belts.
3. Remove belts.
4. Place new belts around pulleys.
5. Tighten belts as described in Tightening Belts (Electric Drives) on page 34.
6. Re-attach guards.

### 6.2.6. TIGHTENING BELTS (ELECTRIC DRIVES)

If the **drive belts are slipping**, the belt should be tightened by turning the adjustment nuts clockwise (see Figure 6.2) until the belt is tight enough so that it does not slip.

If the **drive belts have been over-tightened**, the belts will wear quickly and extra stress will be placed on the pulleys. In this case, the belt tension should be lessened by turning the adjustment nuts counter-clockwise (see Figure 6.2).

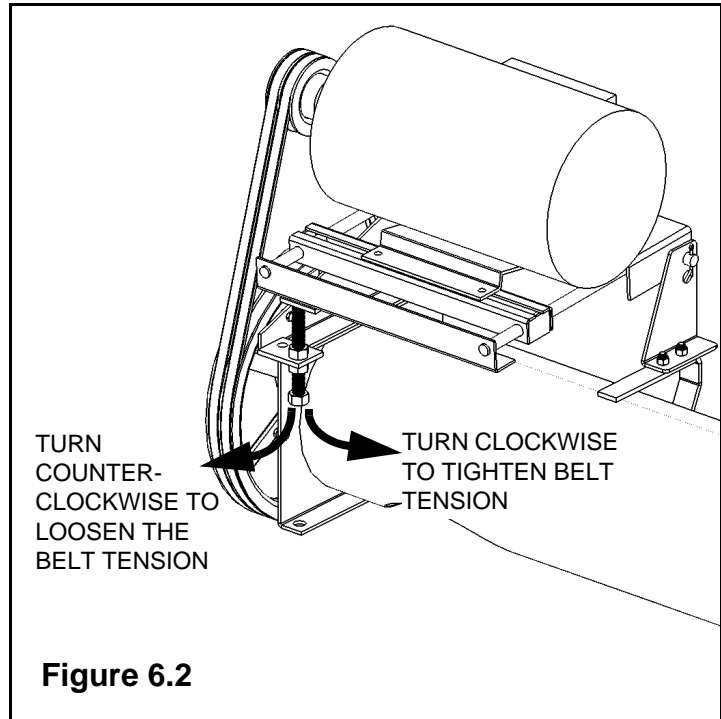

# 7. Storage

**Warning:** Before continuing, please reread the safety information relevant to this section at the beginning of this manual. Failure to follow the safety instructions can result in serious injury, death, or property damage.

To ensure a long, trouble-free life, follow this procedure when preparing the unit for storage after the season's use.

- Lock out all power:
- Follow maintenance procedures. See "Maintenance" on page 31.
- Store the machine on a level surface, free of debris, and in an area away from human activity. Store in a dry place, or use a tightly secured tarp to protect the equipment from the weather.
- Inspect the unit at stress points for cracks.
- Repair or replace any worn or damaged components to prevent any unnecessary downtime at the start of the next season.
- Touch up paint nicks and scratches to prevent rusting.
- Inspect and tighten all fasteners; replace fasteners if required.
- Support intake on blocks to eliminate prolonged contact with the ground.
- Cover motor to protect from weather.
- Chock wheels.



# 8. Troubleshooting

The following table lists the causes and solutions to some potential problems you may encounter in operating your machine.

**Table 8.1**

PROBLEM	CAUSED BY	SOLUTION
The auger does not turn.	• auger is plugged or obstructed	• identify and remove obstruction
	• drive belt is slipping (Electric Model)	• adjust the tension of the belt
	• a bearing is seized	• identify the bearing and replace
	• a chain is broke (Low Profile Model)	• identify the chain and repair or replace
Auger is noisy.	• obstruction in the auger	• identify and remove obstruction
	• auger shaft is bent	• repair or replace auger
	• flighting is damaged	
	• worn bearing	• repair or replace bearing
Low material augering rate.	• inadequate material flow from truck or hopper	• increase flow of material
	• flow into the auger intake is restricted	• clear grating of obstructions
	• material too wet or heavy	• unloading rates are for dry grain
	• flighting is worn	• repair or replace as required
	• belt slipping (Electric Model)	• identify the belt; adjust or replace as required



# WARRANTY

Westfield Industries Ltd. warrants products of its manufacture against defects in materials or workmanship under normal and reasonable use for a period of one year after date of delivery to the original purchaser.

Our obligation under this warranty is limited to repairing, replacing, or refunding defective part or parts which shall be returned to a distributor or a dealer of our Company, or to our factory, with transportation charges prepaid. This warranty does not obligate Westfield Industries Ltd. to bear the cost of labor in replacing defective parts. Any defects must be reported to the Company before the end of the one year period.

This warranty shall not apply to equipment which has been altered, improperly assembled, improperly maintained, or improperly repaired so as to adversely affect its performance. Westfield Industries Ltd. makes no express warranty of any character with respect to parts not of its manufacture.

The foregoing is in lieu of all other warranties, expressed or implied, including any warranties that extend beyond the description of the product, and the IMPLIED WARRANTY of MERCHANTABILITY is expressly excluded.

WESTFIELD INDUSTRIES LTD.

ROSENORT, MANITOBA

CANADA

ROG 1W0

***WESTFIELD***<sup>®</sup>

Westfield Industries is a Division of Ag Growth Industries LP

Part of the Ag Growth International Inc. Group

P.O. Box 39

Rosenort, Manitoba, Canada R0G 1W0

Phone: (866) 467-7207 (Canada & USA)

Fax: (866) 768-4852

website: [www.grainaugers.com](http://www.grainaugers.com)

email: [sales@grainaugers.com](mailto:sales@grainaugers.com)

© Ag Growth Industries Limited Partnership 2010

Printed in Canada