

WESTFIELD[®]

GRAIN AUGERS

MK 80/100 x 51'-81'

ASSEMBLY & OPERATOR MANUAL

Read and understand these instructions before assembling or operating.



MK-02-06



Watch for this symbol. It identifies potential hazards to health or personal safety. It points out safety precautions. It means: **ATTENTION - Be alert. Your safety is involved.**

Failure to read this auger manual before operating the auger is a misuse of the equipment and a needless risk of life and limb.



Table of Contents

1. Introduction	Page 2
2. Safety	3
3. Assembly	11
4. Transport	33
5. Placement	35
6. Operation	38
7. Hydraulics	43
8. Maintenance & Storage	47
9. Index	51
Sign-Off Form	Inside Front Cover
Warranty	Inside Back Cover

1. Introduction

Congratulations. As the new owner of a WESTFIELD MK Series Grain Auger, you will be working with equipment especially designed to complement and improve your farming operation. Before using this auger, we recommend that you read this manual and familiarize yourself with the various features of the machine and the necessary precautions for an efficient and safe operation.

In addition, we suggest that anyone using this auger be required as a matter of record to be familiar with all safety precautions. A sign-off form is supplied on the inside front cover to record your safety reviews.

Thank you.



2. Safety First

Safety First. Everyone knows about it. Most people practice it. Sadly, a few choose to ignore it. Safety should be a habit, something you practice every time you work with machinery. Safe working habits prevent needless injuries or deaths.

Whether you are the owner, a supervisor, or an operator, it is **your** responsibility to know the operational requirements, the safety precautions, and

the potential hazards of portable grain augers. Further more, you must ensure that anyone working with or around the auger, is familiar with them. Failure to read this manual and/or non-compliance with correct safety procedures is a misuse of the equipment. Remember, a lack of knowledge serves only to endanger yourself and those around you.

TAKE THE TIME - BE ALERT - BE SAFE.

2-1. OPERATIONAL SAFETY

Operational safety means using common sense and knowing and observing proper precautions. Always remember to:

- Keep children and untrained people away from auger work area (see **Figure No. 1**). The area around the auger is not safe for untrained personnel and especially not safe for children.
- Have another person nearby who can shut down the auger in case of accident. It is good practice to always work with a second person around augers.
- Inspect the lift cable before using auger. Replace if frayed or damaged.
- Make certain lift cable is properly seated in cable-sheaves and cable clamps are secure.
- Check for breaks or leaks in the hydraulic system. Repair if damaged.
- Ensure that auger is empty before raising or lowering.
- Remember that the hydraulic lift is faster than a conventional hand crank. Extra caution must be taken to clear area of personnel before raising or lowering.
- Augers are not insulated. Keep away from all electric lines. Electrocutation can occur without direct contact.
- Wear hearing protection when operating auger.
- Do not operate with **any** safety shield removed.
- **Never use a PTO driveline without a rotating shield in good working order. Also ensure shields on auger boot and tractor are in place.**
- **Be certain the PTO driveline is securely attached to the flying shaft and to the tractor before operating.**
- Before starting tractor, be certain that power to the PTO and to the hydraulic system is in the off position.
- Keep body, hair and clothing away from moving parts.
- Operate auger on level ground. Even though the auger is connected to the tractor during operation, tipping can occur.
- Do not disconnect hydraulic couplers when hydraulic system is pressurized.
- Anchor or support discharge end to further stabilize auger and prevent tipping.
- Keep away from the intake hopper during operation.
- Do not operate auger with the service or cleanout doors open or unlatched.
- Shut off and lock out all power to auger before servicing, cleaning or adjusting.

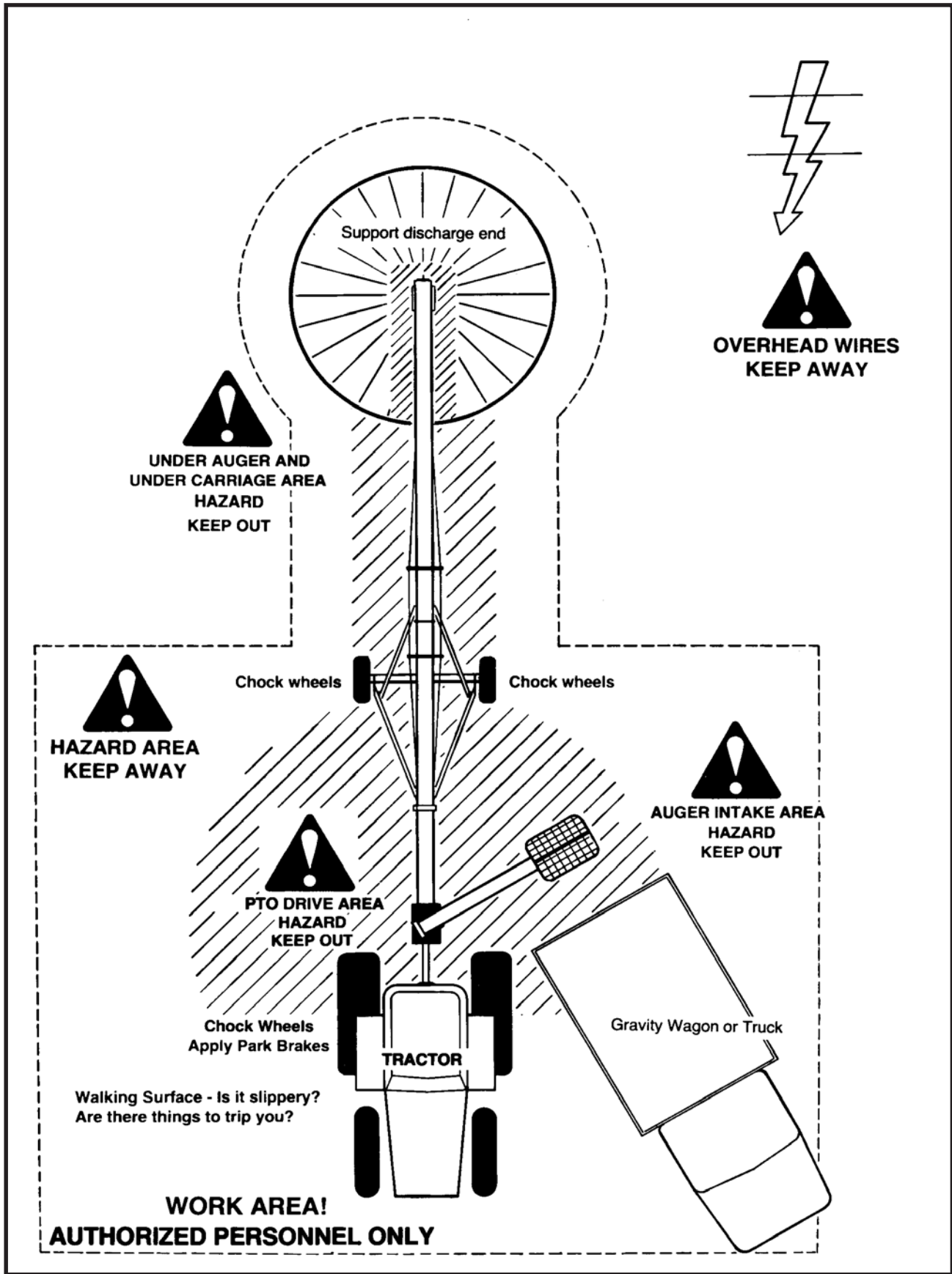

Figure No. 1

- Lower auger at completion of operation, or when not in use. Auger could drop rapidly in case of cable break or hydraulic failure.
- Do not get on or beneath auger when raising or lowering intake hitch jack, or when auger is supported by hitch jack.

2-2. TRANSPORT AND PLACEMENT SAFETY.

The approach to transport and placement safety is no different from that of operational safety. Follow the basic rules of good sense and know the limitations of your machinery. While a few of the precautions are the same, they bear repeating. Remember to:

- Keep children and unauthorized personnel away from the hazard area surrounding the auger.
- Transport auger in the full down position with slight tension on the cable.
- Check the liftcable before each use and replace it if frayed or damaged. Also check cable clamps.
- Make certain that the hitch pin is in place and the safety chain is properly attached. Use a type of hitch pin that will not permit auger to separate from the tractor.
- Always attach a SMV (Slow Moving Vehicle) sign before transporting auger.
- Equip the auger with the necessary lights for transportation where required by law.
- Raise intake feed hopper into transport position and lock hopper lift winch before transporting or moving auger. Intake feed side of hopper must face main auger when in transport position (see **Figure No. 30, page 27**).
- Before moving auger, make sure the area around the auger is clear of obstructions and/or unauthorized personnel. (See **Figure No. 2**).
- Use extreme caution in turning and cornering.
- Do not raise or lower auger until hazard area is clear.

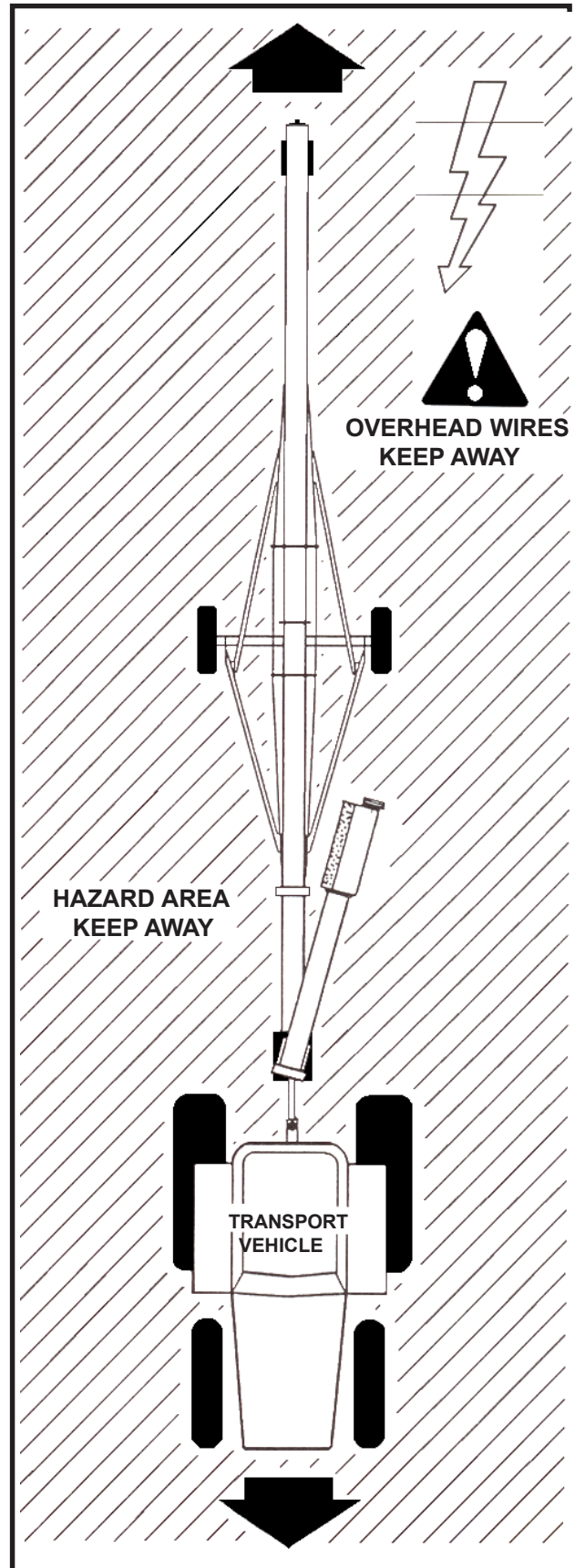

Figure No. 2

- Do not permit anyone to stand on or beneath auger when raising or lowering.
- Wheels must be free to move when raising or lowering auger.
- Do not use auger as a hoist.
- Before moving auger, check and double check for overhead obstructions and/or electrical wires. Electrocutation can occur without direct contact.
- Do not transport auger faster than 15 mph (24 km/h).
- Do not operate auger with intake hopper in transport position. This will cause damage to u-joint.
- Do not transport auger on a slope greater than 20 degrees.
- Disconnect PTO driveline from tractor for transport or placement. Secure in transport saddle.

2-3. HYDRAULIC SAFETY

Hydraulic safety precautions are few in number, but because of the inherent dangers created by the pressures within the system, these precautions are of great importance. Always remember to:

- Keep children and unauthorized personnel away.
- Clean connections before attaching to tractor.
- Inspect hydraulic hose and fittings for damage on a daily basis. Repair if necessary.
- Fluid leaks in the hydraulic lift cylinder or hose will allow the auger to lower inadvertently. Repair all leaks and breaks immediately. The required operating pressure is approximately 1500 PSI

(10335 kPa). Rupture could cause damage and/or personal injury.

NOTE: *On models with hydraulic drive on the intake hopper, the operating pressure is approximately 1800 PSI (12410 kPa).*

- Do not disconnect hydraulic coupler when system is under pressure. Relieve all pressure and then disconnect.
- Wear proper hand and face protection when searching for hydraulic leaks. Escaping fluid under pressure can penetrate the skin, causing infection and/or toxic reaction. In case of accident, see a doctor immediately.

2-4. MAINTENANCE SAFETY

When performing maintenance on the MK auger, understand and observe the following precautions.

- Shut down and lock out all power before attempting maintenance of any kind. If lock-out is impossible, disconnect the PTO driveline from tractor (also hydraulic hoses on units with hydraulic drive hoppers).
- Support auger tube before attempting maintenance on the undercarriage. Auger should be in full down position for maintenance.
- After maintenance is completed, replace and secure all safety shields, safety devices, service doors and cleanout covers.
- Keep decals clean. Replace any decal that is damaged or not clearly visible.
- Use only genuine WESTFIELD replacement parts or equivalent. Replacement parts such as intake shields, pulley shields, PTO driveline shields, winches and lift cables MUST MEET ASAE Standards or serious injury may result. Use of unauthorized parts will void warranty. If in doubt, contact WESTFIELD or your WESTFIELD dealer. Do not modify any auger components.

⚠ CAUTION

1. Read and understand operator's manual before assembling or operating this auger.
2. Do not remove or modify any safety shield or device. Keep in good working order.
3. Clear work area of CHILDREN and untrained personnel before operating or moving auger.
4. Keep body, hair and clothing away from auger intake and all moving parts.
5. Stop auger and lockout power to adjust, service or clean.
6. Fully lower auger to move or service. Use safety chain to transport.
7. Stay clear of power lines when positioning or moving auger. Once positioned, chock all wheels.
8. Trained personnel must be in attendance when auger is in operation.
9. Disassembling certain components will allow auger to collapse. Support auger tube to prevent this.
10. Electric motors must be grounded. Disconnect power before resetting overloads.
11. If the manual, safety shields or decals are missing or damaged, contact factory or your dealer for replacements.

MADE IN CANADA 17119

⚠ WARNING

ROTATING FLIGHTING INSIDE

Do not operate auger with assembly access plates on swing-hopper removed.
FAILURE TO HEED WILL RESULT IN SERIOUS INJURY.

MADE IN CANADA 17112

⚠ DANGER

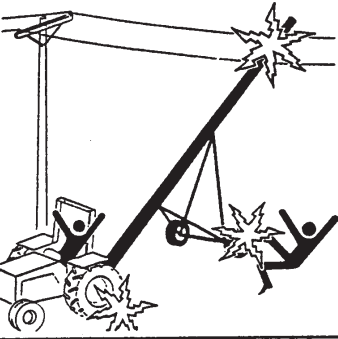

ELECTROCUTION HAZARD

This auger is not insulated.
 Keep auger away from overhead power lines and devices.
 Electrocution can occur without direct contact.
 Fully lower auger before moving.
FAILURE TO KEEP AWAY WILL RESULT IN SERIOUS INJURY OR DEATH.

MADE IN CANADA 17388

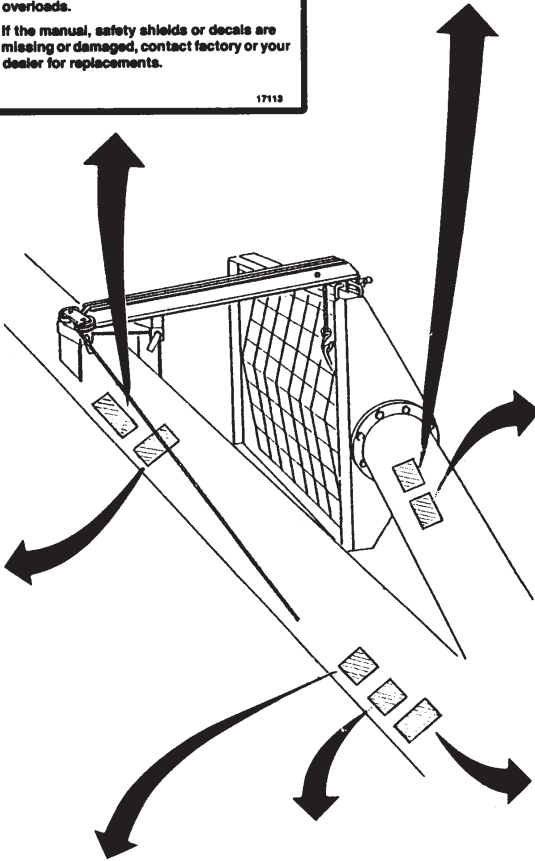

⚠ DANGER



ROTATING FLIGHTING HAZARD

Keep away from auger intake.
 Keep intake shield in place and in good working order. Do not modify.
FAILURE TO HEED WILL RESULT IN SERIOUS INJURY OR DEATH.

MADE IN CANADA 17098

⚠ DANGER

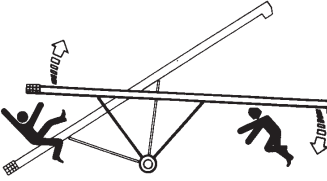

UPENDING HAZARD

Anchor intake end and/or support discharge end to prevent upending.
 Auger intake must always have downward weight. Do not release until attached to tow bar or resting on ground.
 Do not raise auger intake above tow bar height.
 Use a tow vehicle to move auger.
 Empty auger and lower fully before moving.
FAILURE TO HEED WILL RESULT IN SERIOUS INJURY OR DEATH.

MADE IN CANADA 17097

⚠ DANGER



KEEP CHILDREN AWAY.

This auger is not a toy.
 The work area is not a playground.
 Do not allow children to play on or near this auger at any time.
FAILURE TO HEED WILL CAUSE SERIOUS INJURY OR DEATH.

MADE IN CANADA 17095

⚠ WARNING

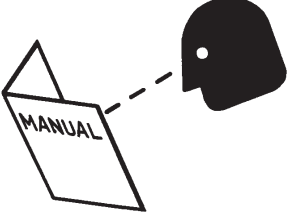

DO NOT OPERATE THIS AUGER unless

1. You are trained to operate it safely.
2. You have read and understand the operator's manual.
3. You know and follow all safe operating procedures and work rules.
4. Children and untrained personnel are removed from work area.

FAILURE TO FOLLOW SAFETY INSTRUCTIONS IN MANUAL WILL SUBJECT OPERATOR AND OTHERS TO SERIOUS INJURY OR DEATH.

MADE IN CANADA 17096

Figure No. 3

⚠ DANGER



ROTATING PTO DRIVELINE HAZARD

Keep your body, hair, clothing and others away from rotating PTO driveline.

Do not operate auger unless all driveline, tractor and equipment shields are in place and in good working order.

Make certain the driveline shields turn freely on driveline.

Make certain the driveline is securely attached at both ends.

Do not exceed operating speed of 540 RPM.

Keep u-joints angles small and equal. Do not exceed maximum recommended length.

FAILURE TO HEED WILL RESULT IN SERIOUS INJURY OR DEATH.

MADE IN CANADA 17103

⚠ WARNING

ROTATING FLIGHTING INSIDE

Do not operate auger with safety discharge door not in place.

FAILURE TO HEED WILL RESULT IN SERIOUS INJURY

NOTE: Should grain overflow through safety discharge door, reduce volume of feed to hopper.

MADE IN CANADA 17111

⚠ CAUTION

Do not exceed operating speed of 540 RPM.

MADE IN CANADA 17110

⚠ CAUTION

Close valve in lift cylinder hydraulic line after having raised auger into position.

MADE IN CANADA 17107

⚠ DANGER



ROTATING FLIGHTING INSIDE

Do not operate auger unless swing-hopper is securely attached to boot.

FAILURE TO HEED WILL RESULT IN SERIOUS INJURY OR DEATH.

IMPORTANT: Do not operate auger with swing-hopper in transport position. This will damage the u-joint.

MADE IN CANADA 17094

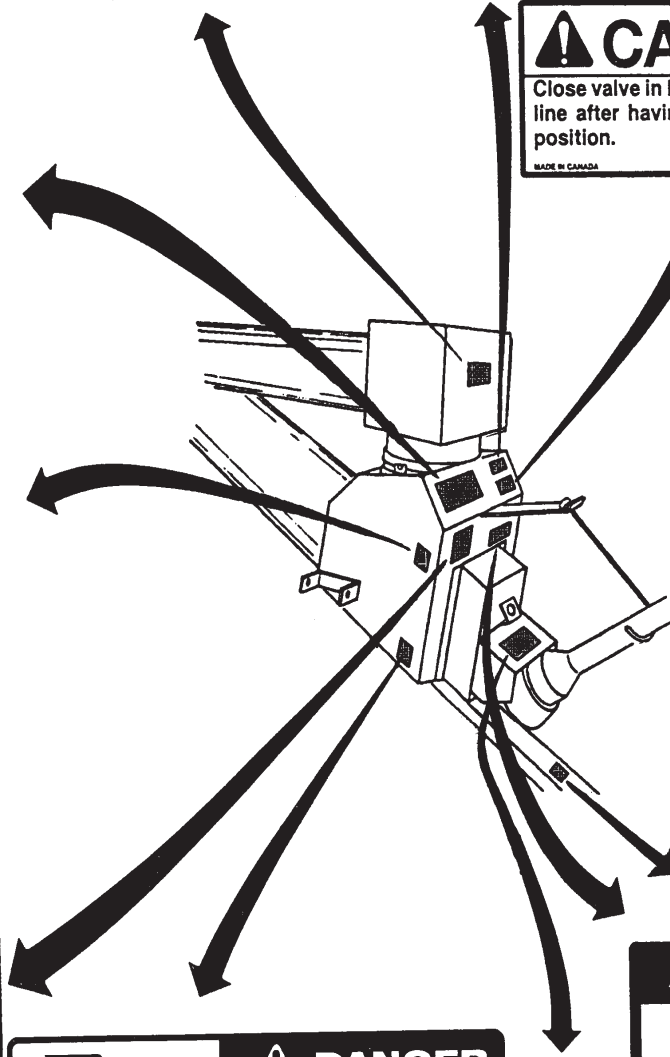

⚠ IMPORTANT

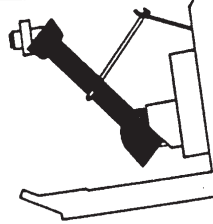

Disconnect PTO driveline from tractor to position or transport auger OR driveline will bottom out severely damaging the CV u-joint and lower flight shaft.

See manual for maintenance.

MADE IN CANADA 18559

⚠ DANGER



ROTATING DRIVE HAZARD

Do not operate auger with shield removed.

FAILURE TO HEED WILL CAUSE SERIOUS INJURY

MADE IN CANADA 17114

⚠ DANGER

ROTATING FLIGHTING INSIDE

Do not operate auger with the service or cleanout door open or unlatched.

SHUT OFF and LOCKOUT power to adjust, service or clean.

Use stick or other tool to clean out.

FAILURE TO HEED WILL RESULT IN SERIOUS INJURY OR DEATH.

MADE IN CANADA 17342

IMPORTANT !

WHEELS MUST BE FREE TO MOVE WHEN RAISING OR LOWERING AUGER

MADE IN CANADA 1990

IMPORTANT CORRECT AUGER TO TRACTOR HOOKUP.

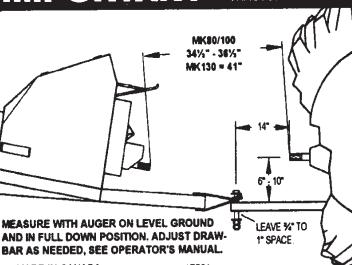

MK80/100 34 1/2" - 35 1/2"
MK130 = 41"

14"
6" - 10"
LEAVE 3/4" TO 1" SPACE

MEASURE WITH AUGER ON LEVEL GROUND AND IN FULL DOWN POSITION. ADJUST DRAWBAR AS NEEDED, SEE OPERATOR'S MANUAL.

MADE IN CANADA 17531

Figure No. 4

! WARNING



ESCAPING HYDRAULIC OIL
 under pressure will cause serious injury if it penetrates the skin. See a doctor immediately if injured.

Relieve pressure before disconnecting hydraulic line.

Use cardboard as a backstop when searching for leaks. Wear proper hand and eye protection.

Inspect frequently. Keep in good repair.

FAILURE TO HEED WILL CAUSE SERIOUS INJURY.

MADE IN CANADA 17100

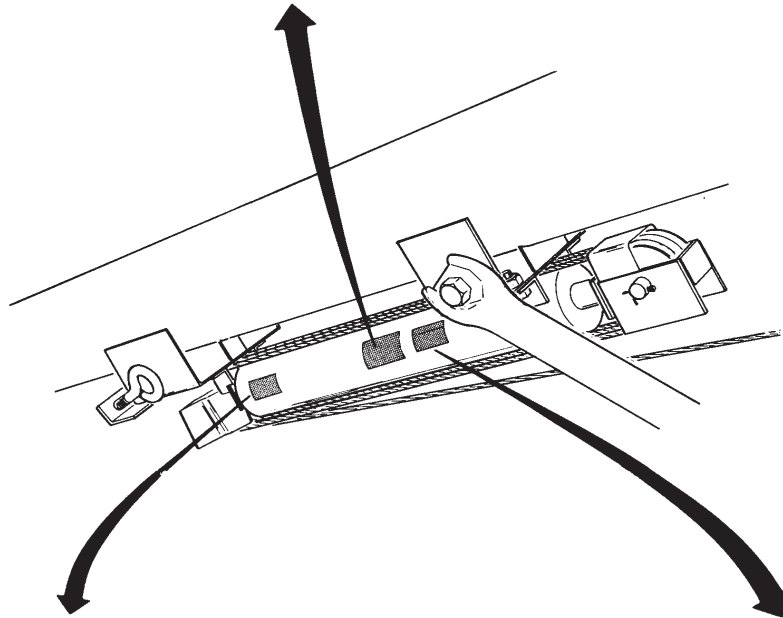

! WARNING

Inspect lift cable frequently.
 If damaged, replace immediately.
 Make certain cable clamps are securely tightened.
FAILURE TO HEED WILL CAUSE SERIOUS INJURY OR DEATH.

MADE IN CANADA 17108

! WARNING

ROTATING CABLE SHEAVES
 Keep away from rotating cable sheaves and cables.
 Do not touch or grab cable while auger is being raised or lowered.
FAILURE TO HEED WILL RESULT IN SERIOUS INJURY.

MADE IN CANADA 17105

Figure No. 5

Note: On MK augers with hydraulic drive hoppers, decals no. 17100 and 17112 are also placed on the hopper powerhead.

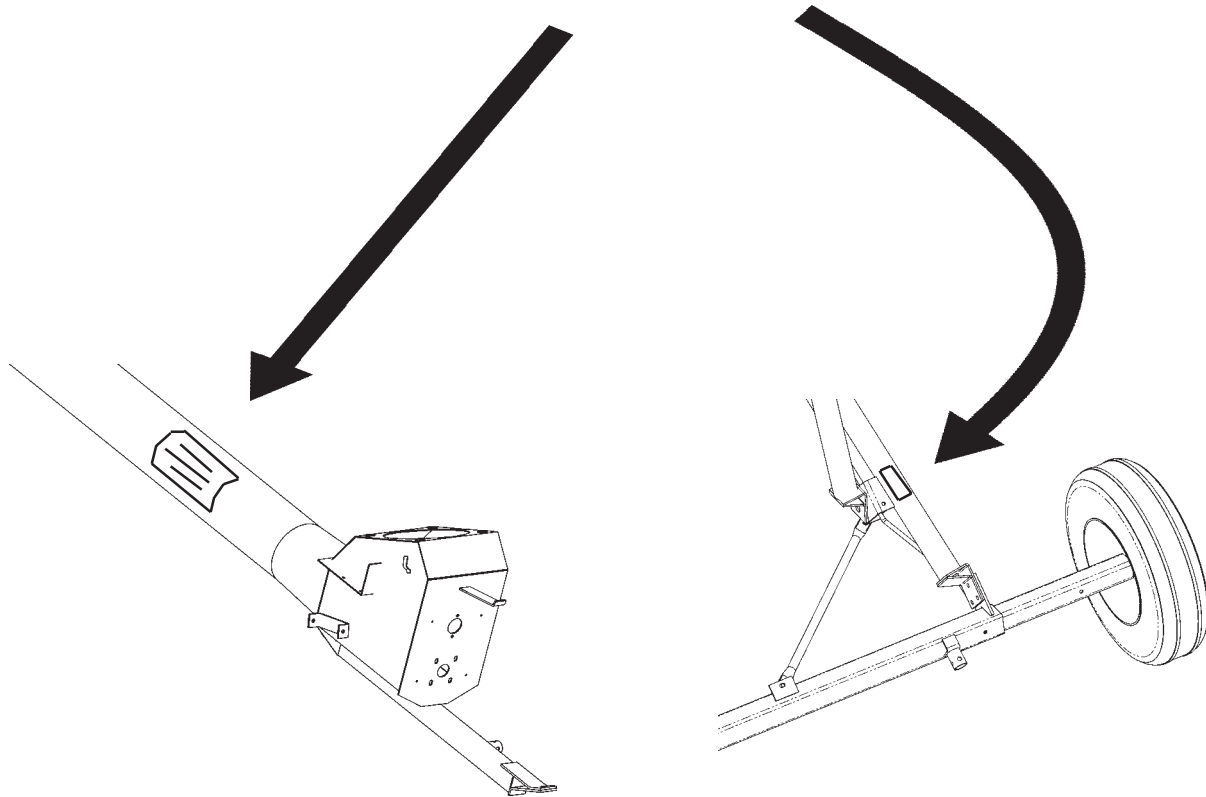
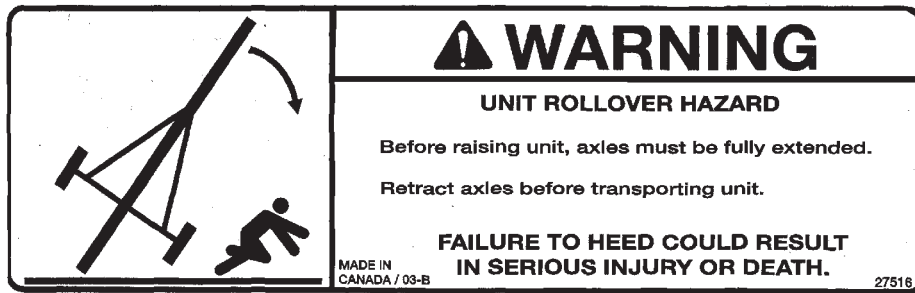

NOTE: This warning decal is included on all MK100-81 grain augers. The decal is found on the lower reach arms and lower tube.

Figure No. 5A

4. Transport

The MK80 / MK100 Grain Augers are designed to be transported and/or operated without unhitching unit from tractor. We strongly advise that all safety precautions be observed before transporting auger.

CAUTION



KEEP CHILDREN AND ALL UNAUTHORIZED PERSONNEL AWAY.

ATTACH A SMV SIGN BEFORE TRANSPORTING AUGER ON A PUBLIC ROAD.

DO NOT TOW FASTER THAN 15 MPH (24KM/H).

USE EXTREME CAUTION IN TURNING AND CORNERING.

DO NOT TOW AUGER ON SLOPES GREATER THAN 20 DEGREES.

DO NOT ALLOW PERSONS TO RIDE ON THE AUGER WHEN IT IS BEING TRANSPORTED. (See Figure No. 2)

ALWAYS TOW AUGER IN THE LOWERED POSITION.

DISCONNECT PTO DRIVELINE FROM TRACTOR FOR TRANSPORT AND PLACEMENT.

2. Make certain that the hitch pin and safety chain are in place and secure. Place safety chain through clevis welded to auger hitch tube and bolt together before attaching to tractor (see **Figure No. 36**).

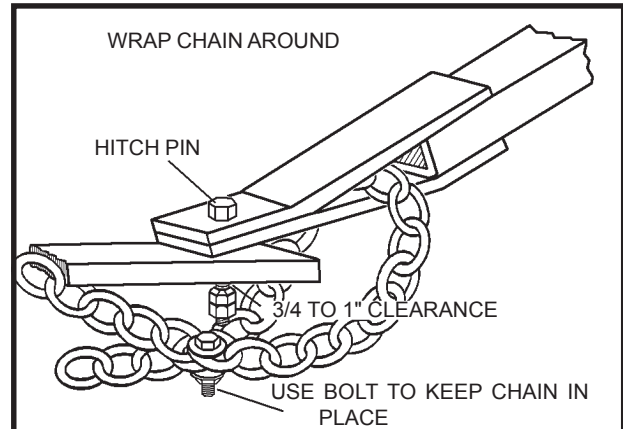

Figure No. 36

3. Ensure that the intake feed hopper is raised into transport position and secured with saddle pin and hairpin (see **Figure No. 37**). DO NOT OPERATE AUGER WITH INTAKE HOPPER IN TRANSPORT POSITION. THIS WILL DAMAGE THE U-JOINT.
4. Ensure that the swivel jack (on side of hitch) is in transport position and locked.

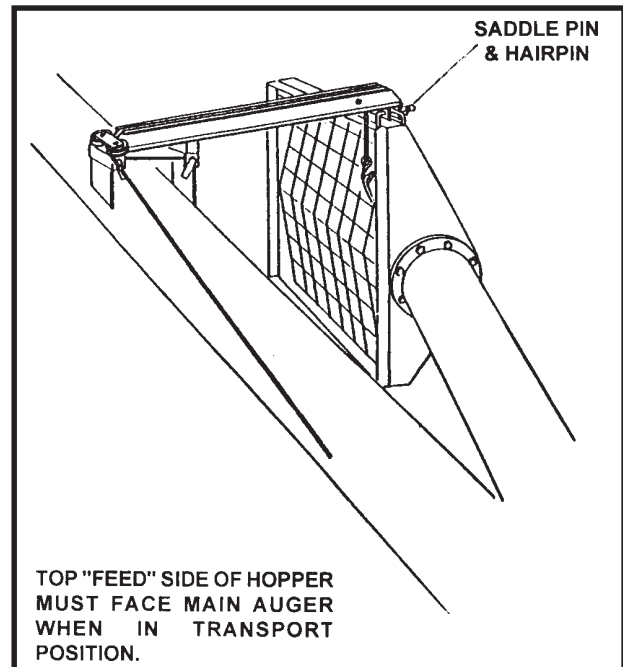

Figure No. 37

4-1. PRE-TRANSPORT CHECKLIST

Before transporting auger, ensure that:

1. Auger is in full down-position with PTO driveline disconnected from tractor. The lift-assist arm must be seated against the track and the trackshoe against the trackstop with slight tension on the lift cable (see **Figure No. 24** on page 23).

IMPORTANT

CHECK LIFT CABLE BEFORE EACH USE. REPLACE IF FRAYED OR DAMAGED.

NOTE: *If auger wheels are partially or fully buried in snow or grain, do not attempt to move auger until snow or grain has been cleared away from auger wheels. Failure to heed may cause damage to auger and/or serious injury.*

IMPORTANT

INTAKE FEED SIDE OF HOPPER MUST FACE MAIN AUGER WHEN IN TRANSPORT (see **Figure No. 37**).

4-2. TRANSPORT PROCEDURE

When transporting the auger, remember to:

1. Ensure that all unauthorized personnel are clear of transport zone. (See **Figure No. 2** on page 5)
2. Be alert to overhead obstructions and electrical wires and devices. The MK80/MK100 augers have minimum clearances from 12'0" to 14'0" (3.66 m to 4.30 m), with auger hitch at 20".

DANGER



ELECTROCUTION HAZARD.

THIS MACHINE IS NOT INSULATED. KEEP AWAY FROM OVERHEAD WIRES AND DEVICES. ELECTROCUTION CAN OCCUR WITHOUT DIRECT CONTACT.

FAILURE TO MAINTAIN PROPER CLEARANCE WILL RESULT IN SERIOUS INJURY OR DEATH.

3. Do not transport auger at speeds greater than 15 mph (24 km/h).
4. Observe all regulations concerning marking, towing, and maximum width.
5. Equip the auger with the necessary lights where required by law.
6. Do not transport auger on slopes greater than 20 degrees.
7. Use extreme caution in turning and cornering when towing auger.

! IMPORTANT

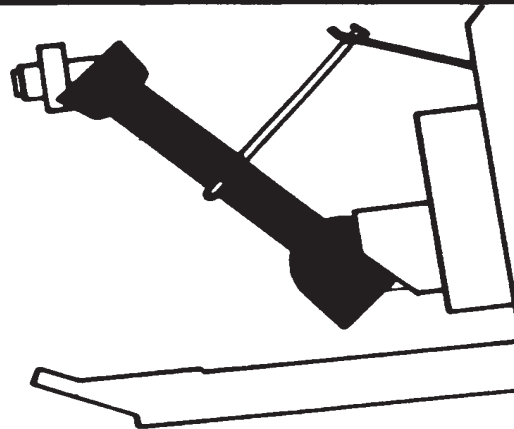

Disconnect PTO driveline from tractor to position or transport auger OR driveline will bottom out severely damaging the CV u-joint and lower flight shaft.

See manual for maintenance.

MADE IN CANADA

18859

5. Placement

Before moving auger into position for operation, ensure that all safety precautions and placement procedures are observed.

CAUTION



KEEP CHILDREN AND ALL UN-AUTHORIZED PERSONNEL AWAY.

ENSURE THAT AREA IS CLEAR BEFORE RAISING OR LOWERING AUGER.

DO NOT ATTEMPT TO MOVE AUGER BY HAND.

ALWAYS CHOCK WHEELS AFTER POSITIONING AUGER FOR OPERATION.

5-1. PRE-PLACEMENT PROCEDURE

Before positioning the auger for operation, the following steps are recommended:

1. Ensure that the towing hitch is in place and secured.

PTO driveline must be disconnected from tractor for placement.

NOTE: *We recommend that a type of hitch pin be used that will not allow auger to separate from tractor (see Figure No. 35). Hitch pin must have proper clearance.*

2. Check that hydraulic connections are tight. If there are leaks, or damage to the hose, replace before proceeding. Replacement hose and hose ends must have a minimum strength of 2750 PSI (18961 kPa) working pressure.

WARNING



AUGER MUST BE HOOKED UP TO TRACTOR FOR ALL OPERATIONS, INCLUDING TRANSPORT, RAISING, PLACEMENT, AND AUGERING GRAIN.

NEVER ATTEMPT TO MOVE AUGER MANUALLY. TO DO SO WILL RESULT IN SERIOUS INJURY.

3. Ensure that the auger is on reasonably level ground when raising or lowering or when positioning.

IMPORTANT

AUGER COULD TOPPLE IF GROUND IS TOO UNEVEN, DAMAGING EQUIPMENT AND/OR CAUSING INJURY.

4. Before raising or positioning auger, make sure that entire area in line of travel, both on the ground and overhead, is clear of any obstructions or electrical wires.

DANGER



WATCH FOR OVERHEAD ELECTRICAL WIRES. ELECTROCUTION CAN OCCUR WITHOUT DIRECT CONTACT. FAILURE TO HEED THIS WARNING WILL RESULT IN SERIOUS INJURY OR DEATH.

5. Disconnect PTO driveline from tractor and secure in transport saddle.

If the auger must be raised for positioning, the procedure is as follows:

IMPORTANT

WHEELS MUST BE FREE TO MOVE WHEN RAISING OR LOWERING AUGER.

NOTE: *If auger wheels are partially or fully buried in snow or grain, do not attempt to move auger until snow or grain has been cleared away from auger wheels. Failure to heed may cause damage to auger and/or serious injury.*

1. Check that valve on hose to lift cylinder is open.
2. Check that the area above and around auger is clear.
3. Raise auger to the desired height.
4. Close hose valve (after auger is positioned).

IMPORTANT

IF HOSE VALVE REMAINS OPEN, A LOSS OF HYDRAULIC PRESSURE WITHIN THE TRACTOR SYSTEM WILL ALLOW THE AUGER TO LOWER INADVERTENTLY, DAMAGING EQUIPMENT AND/OR CAUSING PERSONAL INJURY.

NOTE: *For MK AUGERS WITH HYDRAULIC DRIVE INTAKE HOPPERS: If your tractor is equipped with a single hydraulic system, relieve pressure and disconnect lift hose to connect hydraulic motor hoses.*

WARNING



DO NOT DISCONNECT COUPLER UNDER PRESSURE. RELIEVE PRESSURE AND THEN DISCONNECT.

5-2. PLACEMENT PROCEDURE

1. Move the auger into working position slowly, making sure that all persons are clear of the hazard zone (see **Figure No. 1** on page 4). **DO NOT UNHITCH AND ATTEMPT TO MOVE THE AUGER BY HAND.**

IMPORTANT

WHEN POSITIONING THE MK AUGER, THE PTO DRIVELINE MUST BE DISCONNECTED FROM THE TRACTOR AND PLACED IN THE TRANSPORT SADDLE TO PREVENT DAMAGE TO AUGER AND PTO DRIVELINE. (See **Figure No. 33** on page 28)

2. Once auger is in position, wheels should be chocked on both sides as well as applying the park brake on tractor (or chocking it's wheels) to prevent movement during operation.

WARNING



NEVER ATTEMPT TO INCREASE HEIGHT OF AUGER BY POSITIONING WHEELS ON LUMBER, BLOCKS, OR BY ANY OTHER MEANS. TO DO SO WILL RESULT IN DAMAGE TO EQUIPMENT AND/OR PERSONAL INJURY.

3. When operating auger in the raised position, rest the discharge end lightly on bin roof, or tie down to bin to prevent wind upsetting auger.
4. Fully lower hopper to the ground and remove lift cable from the hopper.
5. See **Section 6-7** for correct lowering procedure.

NOTE: *If auger wheels are partially or fully buried in snow or grain, do not attempt to move auger until snow or grain has been cleared away from auger wheels. Failure to heed may cause damage to auger and/or serious injury.*

CAUTION



DO NOT USE AUGER AS A HOIST TO RAISE ANY OBJECT REGARDLESS OF WEIGHT. THIS WILL CREATE AN UNSAFE CONDITION AND WILL VOID WARRANTY.

AXLE EXTENSION PROCEDURE FOR MK 100-81 AUGER ONLY

Be sure that the auger is on level ground before attempting to extend or retract the axle extensions.

AUGER MUST BE ATTACHED TO TRACTOR AT ALL TIMES

Once the auger is located you may begin the axle extension process.

1. Using the jack supplied, insert it into one of the jack lugs located on one end of the axle. See **Figure No. 37A** for jacking point. Jack must be secured to jack lug using pin (attached to jack). One side will be raised at a time. Ensure that the jack is oriented in a vertical position. Turn the crank to start raising the jack. Raise one side of the axle until the tire clears the ground.
2. Remove the axle pin from the axle as seen in the **Figure No. 37A**. Slide the axle outwards (16 inches) until the second set of holes line up. Reinsert the pin and secure with snap pin. Lower the jack.
3. Repeat the process on the other side of the axle to extend the other side.

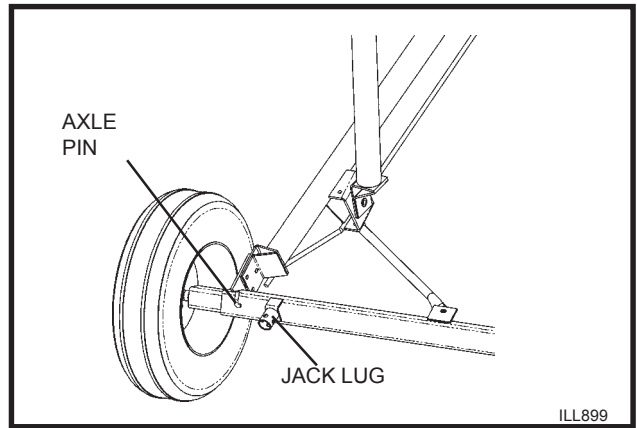



Figure No. 37A

WARNING	
	DO NOT RAISE THE AUGER UNLESS THE AXLES ARE IN THE EXTENDED POSITION.
BE ALERT	

4. Use the same procedure, in reverse, to retract the axle.

WARNING	
	DO NOT TRANSPORT THE AUGER UNLESS THE AXLES ARE IN THE RETRACTED POSITION.
BE ALERT	

6. Operation

The MK80 / MK100 augers require that operators follow the checklist before each start-up and that safety procedures are observed at all times. To do otherwise is endangering life and limb, and is a misuse of the equipment.

CAUTION

KEEP ALL CHILDREN AND UNAUTHORIZED PERSONNEL CLEAR OF WORK AREA. (See Figure No. 1)

DO NOT OPERATE AUGER WITH ANY SAFETY SHIELDS REMOVED.



DO NOT OPERATE AUGER WITH ANY SERVICE, CLEAN-OUT OR ACCESS DOOR OPEN OR UNLATCHED OR WITH SAFETY DISCHARGE DOOR OPEN.

ALWAYS HAVE ANOTHER PERSON NEARBY TO SHUT DOWN AUGER IN CASE OF ACCIDENT.

WEAR HEARING PROTECTION DURING OPERATION.

KEEP BODY, HAIR AND CLOTHING AWAY FROM ANY MOVING PARTS.

SHUT DOWN AND LOCK OUT ALL POWER BEFORE SERVICING, CLEANING, OR ADJUSTING AUGER.

6-1. PRE-OPERATIONAL CHECKLIST

Before operating auger for the first time, and each time thereafter, the operator must follow the checklist, which should confirm the following:

- All fasteners are secured as per assembly instructions.
- Lift cable is not frayed or damaged.
- Lift cable is properly seated in cable sheaves.
- Cable clamps are secure.
- Hydraulic hose is in good condition.
- Hydraulic connections are in place and secure.
- PTO driveline is connected and secure.
- PTO driveline shield rotates freely.

- Clean-out and service doors and access covers are in place and secure and safety discharge door is closed.
- All safety shields are in place and secure.
- Tube alignment is reasonably straight.
- Intake hopper and discharge spout are free of obstructions.
- Auger wheels are chocked and tractor wheels are chocked or parking brake is applied.
- A second qualified person is present during operation.
- Operators are aware of safety precautions.
- Proper maintenance is performed.
- Tractor and auger are in line or as close to being in line as possible.

6-2. AUGER DRIVE AND LOCKOUT

A: PTO Driveline

1. Ensure that the PTO driveline is securely attached to the fighting shaft and to the tractor.
2. Do not use a PTO driveline without a rotating shield that is in good working order.
3. Be certain that safety shields are in place and secure on tractor and auger.
4. The maximum operating length of the PTO driveline from end to end is 40-5/8". Do not exceed this length.

NOTE: *If shearbolt in the PTO driveline fails, shutdown and lock out tractor to replace bolt.*

MK80 uses a 5/16" x 1" grade 8 bolt — through the thread shear (as per drawing)

MK100 uses a 5/16" x 1" grade 8 bolt — through shank shear (as per drawing)

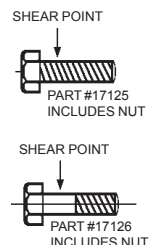

5. Be sure the PTO drive on tractor is in the OFF position (also hydraulics on units with hydraulic drive hopper) before starting the tractor.
6. Stay clear of the PTO hazard area. (See **Figure No. 1** on page 4)

B: Hydraulics

1. Ensure that the hydraulic line is properly connected and secure.
2. Keep hydraulic line away from moving parts.

WARNING



ESCAPING HYDRAULIC FLUID UNDER PRESSURE CAN CAUSE SERIOUS INJURY IF IT PENETRATES THE SKIN. WEAR PROTECTIVE CLOTHING WHEN WORKING AROUND HYDRAULIC EQUIPMENT.

3. Do not disconnect the hydraulic couplers when under pressure. Consult **Section 7** for the correct procedure, or consult the tractor manual.

Lockout and/or Shutdown

1. Shut off engine and remove ignition key or coil wire from tractor.
2. If step 1 is not possible, remove PTO driveline from tractor (and disconnect hydraulic hoses on units with hydraulic drive hopper).

6-3. START UP AND BREAK IN

Start up and break in procedure for the MK80 / MK100 auger is as follows:

NOTE: *The angle drive requires a break-in period of at least 2 or 3 loads of grain.*

1. Ensure that you have completed the pre-operational checklist in **Section 6-1**.
2. If everything is satisfactory, prepare for a 60 minute operation at half speed.
3. Ensure that the intake hopper is correctly positioned.
4. Ensure that the PTO drive on the tractor is in the OFF position (also hydraulics on units with hydraulic drive hopper).

CAUTION



BE ALERT

DO NOT START AUGER UNTIL AREA IS CLEAR OF ALL UNAUTHORIZED PERSONNEL. ALWAYS WORK WITH A SECOND PERSON DURING OPERATIONS.

AUGER MUST BE HOOKED UP TO TRACTOR FOR ALL OPERATIONS, INCLUDING TRANSPORT, RAISING, PLACEMENT AND AUGERING OF GRAIN. DISCONNECT PTO DRIVELINE FROM TRACTOR FOR TRANSPORT AND PLACEMENT.

IMPORTANT

WHEN STARTING AUGER FOR THE FIRST TIME, BE PREPARED FOR AN EMERGENCY SHUTDOWN IN CASE OF EXCESSIVE VIBRATION OR NOISE. NOTE THAT THE AUGER MAY RUN ROUGH UNTIL TUBE IS POLISHED.

5. Start tractor and **idle at low RPM**. Slowly engage PTO drive (also hydraulics on units with hydraulic drive hopper).
6. Gradually begin feeding grain into hopper bringing auger speed up to about 300 RPM. Do not overfeed the hopper on initial loads, keep feed of grain at about half capacity. After auger tube is polished and runs fairly smoothly, proceed to unload at full speed of 540 RPM.
7. Upon completion of initial run, **slow auger down** until empty of grain and stop.
8. Lock out tractor and conduct a complete inspection of auger following the checklist in **Section 6-1**.
9. After the initial start-up and inspection, auger should be shut down and inspected at least three more times during the first ten hours of operation.
10. Once auger is broken in, the checklist should be a part of the daily routine before operating the auger.
11. Do not run empty auger at high speed, as this results in excessive wear.

After Break-in: Maintain auger speed of 300 to 540 RPM under normal use for maximum efficiency and to reduce chance of plugging.

6-4. FULL LOAD PROCEDURES

For normal auger operations, the following procedure and safety precautions are strongly recommended.

1. Observe the work area hazard zone (see **Figure No. 1** on page 4).
2. When operating the auger, always work with a second person in a position to monitor the operation and initiate a shutdown in case of emergency.
3. Monitor the auger during the actual operation for abnormal noises or vibrations.
4. Shut off all power before making adjustments, servicing, or cleaning machine.

CAUTION

MAKE CERTAIN EVERYONE IS CLEAR BEFORE OPERATING MACHINE.

KEEP ALL SAFETY SHIELDS AND DEVICES IN PLACE AND SECURE.



KEEP HANDS, FEET, HAIR AND CLOTHING AWAY FROM MOVING PARTS.

BE ALERT

DO NOT EXCEED 540 RPM ON THE PTO

DO NOT REMOVE OR OPEN CLEANOUT DOORS WHILE AUGER IS IN OPERATION. DO NOT OPERATE IF CLEANOUT DOORS ARE REMOVED.

NOTE: Reduce volume of feed to intake hopper should grain overflow through safety discharge door. This indicates the main auger is loaded beyond its capacity. Auger capacity will decrease at steeper elevations.

WARNING



KEEP SAFETY DISCHARGE DOOR IN PLACE WHILE OPERATING AUGER. FAILURE TO HEED WILL RESULT IN SERIOUS INJURY OR DEATH.

BE ALERT

NOTE: Engage and disengage PTO drive with tractor engine at idle speed. This will reduce stress on drive components and on shear bolts.

USE OF GRAIN SPREADERS: Most grain spreaders can not handle the large capacity of the MK augers. As a result, the auger will plug causing damage to the flighting and other drive components. This type of damage is not covered by warranty.

Hints on how to avoid this...

- Get a larger spreader, if available
- Remove the spreader
- Make certain spreader is turned on
- Auger spout must be centered on spreader
- Do not lower auger spout into spreader
- Suspend the spreader from bin ceiling leaving lots of room for excess grain to flow over the spreader
- Some farmers have suspended a curved disc about 14" - 16" from bin ceiling which is reported to do a good job of spreading the grain

BIN LEVEL INDICATORS: The MK augers are fast and bins fill up quickly. A full bin will cause auger to plug, which will damage the flighting and other drive components.

Installing quality grain-level indicators on your bins will allow you to monitor the filling of the bin and help prevent damage to your auger.

6-5. NORMAL/EMERGENCY SHUTDOWN

The steps for a **normal shutdown** are:

1. Near the end of a load, **decrease** auger speed until all grain is clear of machine.
2. When auger is clear of grain, disengage PTO drive (also hydraulics on units with hydraulic drive hopper).
3. Shut down and lock out tractor.

In the event of an intermittent or **emergency shutdown**, restart as follows:

1. If auger is full of grain, do not restart at full speed. Engage PTO at low RPM, gradually increasing power until normal operating speed is reached.

IMPORTANT

STARTING THE AUGER UNDER LOAD MAY RESULT IN DAMAGE TO UNIT BE SURE THERE IS NO BLOCKAGE.

2. If the auger is shut down for an emergency, lock out tractor before correcting problem. If the problem is plugging, clear as much of the grain as possible, using a piece of wood, vacuum cleaner or other tool (not your hands), before restarting auger. **DO NOT REACH IN AND USE YOUR HANDS.** (See **Section 6-2** for lockout procedure)

IMPORTANT

IF CLEAN OUT COVERS OR SAFETY DOORS HAVE BEEN OPENED OR REMOVED, CLOSE OR REPLACE THEM BEFORE RESTARTING THE UNIT. OPERATING THE AUGER WITH COVERS REMOVED OR DOORS OPEN IS DANGEROUS.

DANGER

ROTATING FLIGHTING INSIDE.



DO NOT OPERATE AUGER WITH THE SERVICE OR CLEANOUT DOOR OPEN OR UNLATCHED.

SHUT OFF AND LOCKOUT POWER TO ADJUST, SERVICE OR CLEAN.

USE STICK OR OTHER TOOL TO CLEAN OUT. FAILURE TO HEED WILL RESULT IN SERIOUS INJURY OR DEATH.

6-6. COMPLETION / CLEAN-UP

At the completion of an operation, the auger should be moved to the next work area or to a storage area.

The **recommended procedure** is:

1. Clean entire work area.
2. Remove all supports and chocks.
3. After ensuring that area is clear of all unauthorized personnel, move auger out of working position and lower fully. (See **Section 6-7** for lowering procedure)

CAUTION



DO NOT LEAVE AUGER IN RAISED POSITION. AUGER COULD DROP RAPIDLY IN CASE OF CABLE BREAK OR HYDRAULIC FAILURE.

HIGH WIND MAY TOPPLE AUGER.

The proper steps for **clean-out** of the auger are:

1. Disengage PTO (also hydraulics on units with hydraulic drive hopper), lower auger into transport position, shut off tractor engine and lock out power. **Disconnect PTO driveline from tractor before raising or lowering auger.**
2. If necessary open clean-out door on the boot and manually clean out grain, using piece of wood, vacuum cleaner or other tool. **DO NOT USE HANDS.** Replace clean-out cover.
3. Winch intake feed hopper into transport position and clean out grain, using piece of wood or other tool.

6-7. LOWERING PROCEDURE

To lower auger you must:

1. Raise the intake feed hopper. **DO NOT ATTEMPT TO LIFT BY HAND.**
2. Reconnect hose coupler to tractor, if disconnected.
3. Disconnect PTO driveline from tractor before lowering.
4. Ensure that area beneath auger is clear.
5. Open hose valve.
6. Open tractor valve, feathering to prevent too rapid a descent.

IMPORTANT

FOR THE MK 100-81 AUGER, THE TRACTOR MUST BE RUNNING WHILE THE AUGER IS BEING LOWERED.

IMPORTANT

ONCE VALVES ARE OPEN, AUGER LOWERS BY GRAVITY. AS THE AUGER NEARS THE FULL DOWN POSITION, THE RATE OF DESCENT INCREASES. DO NOT OPERATE WITH TRACTOR VALVE FULLY OPEN.

7. After auger is fully lowered, raise the intake feed hopper into full transport position.

DANGER	
	BEFORE MOVING AUGER OUT OF POSITION, LOOK OUT FOR ELECTRICAL WIRES AND OBSTRUCTIONS OVERHEAD. ELECTROCUTION CAN OCCUR WITHOUT DIRECT CONTACT. FAILURE TO HEED THIS WARNING WILL RESULT IN SERIOUS INJURY OR DEATH.

IMPORTANT

DO NOT OPERATE AUGER WITH INTAKE FEED HOPPER IN TRANSPORT POSITION. THIS WILL DAMAGE THE UNIVERSAL JOINT.

IMPORTANT

WHEELS MUST BE FREE TO MOVE WHEN RAISING OR LOWERING AUGER.

6-8. INTAKE FEED HOPPER HYDRAULICS

The speed of the intake feed hopper is regulated by the gallons per minute generated by the hydraulic system of the tractor.

7. Hydraulics

Before connecting the auger hydraulic line, ensure that all safety precautions and correct operating procedures are fully understood.

CAUTION



BE ALERT

KEEP CHILDREN AND UNAUTHORIZED PERSONNEL AWAY.

DO A DAILY VISUAL CHECK FOR DAMAGE TO HOSE AND CONNECTORS AND REPLACE IF NECESSARY.

DO NOT DISCONNECT HYDRAULIC COUPLER WHEN SYSTEM IS PRESSURIZED.

WEAR PROTECTIVE CLOTHING WHEN SEARCHING FOR POSSIBLE LEAKS.

7-1. GENERAL INFORMATION

Because of the varied types of tractor hydraulic systems, the quick-connect coupler is to be supplied by the owners. Please consult your tractor manual or your dealer for the proper coupler.

Observe the following steps when connecting hose to tractor:

1. Before connecting hose, ensure that the quick-connect coupler on auger and tractor is clean and free of dirt by wiping with a cloth.

IMPORTANT

DIRT IN THE HYDRAULIC SYSTEM CAN DAMAGE THE CYLINDER O-RINGS, CAUSING LEAKAGE, AND THE POSSIBLE FAILURE OF THE SYSTEM.

2. After connecting hose, visually check it for leaks, binding, flattening, kinks or wear.

WARNING



BE ALERT

WEAR PROPER HAND AND FACE PROTECTION WHEN SEARCHING FOR HYDRAULIC LEAKS. ESCAPING FLUID UNDER PRESSURE CAN PENETRATE THE SKIN, CAUSING INFECTION OR TOXIC REACTION. SEE A DOCTOR IMMEDIATELY IF INJURED.

ESCAPING HYDRAULIC FLUID CAN BE NEARLY INVISIBLE UNDER HIGH PRESSURE. USE FLAT PIECES OF CARDBOARD OR WOOD AS BACKDROP WHEN SEARCHING FOR LEAKS.

THE REQUIRED OPERATING PRESSURE IS APPROXIMATELY 1500 PSI (10,350 kPa). RUPTURE COULD CAUSE DAMAGE AND/OR PERSONAL INJURY,

7-2. LIFT CYLINDER HYDRAULICS

The MK auger is elevated with a 4 inch (MK 100-81 has a 4-1/2" bore), single acting hydraulic cylinder and cable. The following table lists the PSI required to raise specific auger sizes, as determined by WESTFIELD testing.

These tests were conducted using a hydraulic pressure gauge (4000 PSI maximum rating) and are solely intended to be used as a guide. The PSI requirements for a specific auger may vary slightly. Should your auger require a significantly higher PSI to raise, contact either your dealer or WESTFIELD Industries.

AUGER	SIZE	PSI	kPa
MK 80-51	8" x 51'	850	5865
MK 80-61	8" x 61'	950	6555
MK 80-71	8" x 71'	1200	8280
MK 100-51	10" x 51'	1000	6895
MK 100-61	10" x 61'	1200	8280
MK 100-71	10" x 71'	1500	10342
MK 100-81	10" x 81'	1800	12480

Approximate quantity of hydraulic fluid required to raise auger:

MK - 51'	6.2 litres
MK - 61'	7.5 litres
MK - 71'	9.0 litres
MK - 81'	4.0 litres

The MK 100-81 auger features a unique, new hydraulic lift system, that only needs a small amount of hydraulic oil to raise the auger. This is done by pumping oil in to and out of the upper chamber of the cylinder as the auger is raised and lowered.

For this system to work, THE TRACTOR MUST BE RUNNING and down lever must be fully engaged as auger is lowered.

IMPORTANT

THE HYDRAULIC CYLINDERS ARE SHIPPED WITHOUT OIL AND MUST BE CHARGED WITH OIL BEFORE AUGER IS PUT INTO OPERATION.

HOW TO CHARGE THE LIFT SYSTEM (MK100-81 ONLY)

The cylinder will require about 9 litres (2.5 U.S. gallons). Check your tractor operator's manual for correct oil type and specification.

Before charging cylinders, ensure that:

- tractor is correctly hooked up
 - hydraulic hoses are connected
 - shut-off valve is open
 - auger is parked on level ground
 - do not raise auger in high winds
1. Start with the tractor's hydraulic oil level in normal operating range.
 2. Add about 4 litres (1 U.S. gallon) to the tractor's hydraulic oil reservoir.
 3. START TRACTOR, then raise auger until the lift assist is fully extended and trackshoe has moved about one foot from trackstop.
 4. WITH TRACTOR STILL RUNNING, lower auger to full down position.
 5. Repeat above steps 2, 3, and 4 until about 9 litres (2.5 U.S. gallons) have been added and tractor hydraulic oil level in the reservoir remains within operating range.

To raise auger you must:

1. Ensure that the area above and around the auger is clear of unauthorized personnel, obstructions and/or electrical wires.
2. Check that the valve on hose to lift-cylinder is open.
3. Disconnect PTO driveline.

IMPORTANT

WHEELS MUST BE FREE TO MOVE WHEN RAISING OR LOWERING AUGER.

4. Raise the auger to desired height.
5. Close hose valve.

IMPORTANT

IF HOSE VALVE REMAINS OPEN, A LOSS OF HYDRAULIC PRESSURE WITHIN THE TRACTOR SYSTEM WILL ALLOW THE AUGER TO LOWER INADVERTENTLY, DAMAGING EQUIPMENT AND/OR CAUSING PERSONAL INJURY.

WARNING



DO NOT DISCONNECT COUPLER UNDER PRESSURE. RELIEVE PRESSURE AND THEN DISCONNECT.

FLUID LEAKS IN THE HYDRAULIC CYLINDER OR HOSE WILL ALLOW AUGER TO LOWER INADVERTENTLY. REPAIR ALL LEAKS AND BREAKS IMMEDIATELY.

To lower the auger you must:

1. Reconnect hose coupler to tractor, if disconnected.
2. Disconnect PTO driveline from tractor before lowering.
3. Ensure that area beneath auger is clear.
4. Open hose valve.
5. Open tractor valve, feathering to prevent too rapid a descent.

IMPORTANT

TO LOWER MK 100-81 AUGER, TRACTOR MUST BE RUNNING.

Start tractor, then engage hydraulic lever in down position.

This pumps oil back to upper chamber of the hydraulic cylinders preventing overflow of tractor reservoir.

MADE IN CANADA 17377

IMPORTANT

ONCE VALVES ARE OPENED, AUGER LOWERS BY GRAVITY. AS THE AUGER NEARS THE FULL DOWN POSITION, THE RATE OF DESCENT WILL INCREASE. DO NOT OPERATE WITH TRACTOR VALVE FULLY OPEN.

See **Section 6-7** for more details.

NOTE: *FOR MKAUGERS WITH HYDRAULIC DRIVE INTAKE HOPPERS: If your tractor has a dual hydraulic system, all hoses can be attached at once. If tractor has a single hydraulic system, hoses will have to be alternated, depending on the operation required.*

IMPORTANT

Relieve pressure before switching hoses.

**THIS PAGE APPLIES TO MK AUGERS
WITH HYDRAULIC DRIVE INTAKE
HOPPERS ONLY.**

7-3. INTAKE FEED HOPPER HYDRAULICS

The speed of the intake feed hopper is regulated by the volume and pressure generated by the hydraulic system of the tractor. When tractor engine rpm is increased, the speed of the flighting in the hopper is increased.

The speed of the main auger will also increase, effectively preventing the overloading of the main auger under normal conditions. Should you find the intake feed hopper is overloading the main auger, decrease the amount of grain flow from your truck or trailer.

For the intake feed hopper to function properly, the hydraulic motor must receive adequate gallons per minute (gpm) at a proper pressure (psi). The minimum volumes and pressures are:

1. The 8-inch intake feed hopper must receive a minimum of 8 gpm (36.3 lpm) at 1500 psi (10342 kPa).
2. The 10-inch intake feed hopper must receive a minimum of 10 gpm (45.5 lpm) at 1500 psi (10342 kPa).

NOTE: *The minimum requirements listed in Steps 1 and 2 are essential for efficient auger operation. To improve the capacity: additional gallons per minute will increase the speed of the hydraulic motor (flighting rpm) while a higher pressure will create additional torque to maintain motor speed under load.*

7-4. SPECIAL NOTES

1. Do not exceed a constant backpressure of 300 psi (2068 kPa) in the hydraulic motor. The hydraulic system on some tractors is designed in such a manner that the return flow of hydraulic fluid from the hydraulic motor to the tractor is restricted. This creates excessive backpressure inside the hydraulic motor and deprives it of an adequate flow of hydraulic fluid. The result will be **SEAL FAILURE, OVERHEATING, ROUGH RUNNING, and LOSS OF POWER.**

To date, these problems are occurring primarily with certain models of John Deere tractors. Kits to correct the problem are available from your John Deere dealer. (See **Figure No. 38**)

NOTE: *John Deere Series 50 tractors with a single hydraulic lever will require this kit. Series 50 tractors with double hydraulic levers have the kit pre-installed.*

NOTE: *The problem discussed in this section may exist on tractors other than the John Deere. Should you experience this situation, contact your tractor dealer, or contact Westfield Industries.*

A remote cylinder control valve oil return kit, which returns oil to the oil filter cover, is available for more efficient use of tractor hydraulics. Order AR71945 Remote Cylinder Control Valve Oil Return kit and AT30197 Ported Cover for transmission filter. (See Figure No. 38)

IMPORTANT

A steel-encased filter element must be used with the AT30197 Ported Filter Cover.

W8058

INFORMATION COURTESY JOHN DEERE MANUAL "PREPARING THE TRACTOR."

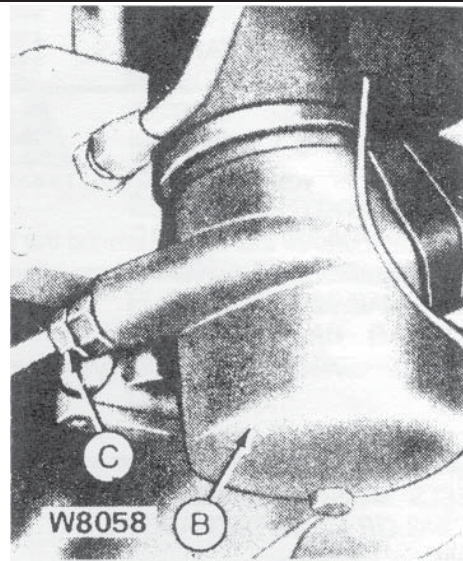

Figure No. 38

8. Maintenance & Storage

Proper maintenance on the MK80 / MK100 augers means a longer life for the machine and a safer and more efficient operation.

CAUTION

KEEP CHILDREN AWAY WHEN PERFORMING MAINTENANCE.

BEFORE PERFORMING ANY MAINTENANCE, ENSURE THAT POWER IS SHUT DOWN AND LOCKED OUT.



BE ALERT

WHERE POSSIBLE, PERFORM MAINTENANCE WITH AUGER IN FULL DOWN POSITION.

REPLACE ALL SHIELDS.

8-1. GENERAL MAINTENANCE PROCEDURE

We recommend the following steps for the general maintenance of this auger:

1. Observe the checklist in **Section 6-1** on a daily basis when auger is in use.
2. Check all operating, lifting and transport components. Replace damaged or worn parts before using auger.

NOTE: *To replace a damaged part, refer to assembly instructions in **Section 3**.*

3. **Intake Hopper Angle Drive** –
Lubricate the angle-drive after every 8 hours of operation. **Use high temperature grease.**

NOTE: *If the angle drive in hopper runs hot AFTER an appropriate break-in period, this may mean the angle drive is not properly aligned. To correct, first lock out power, then loosen bolts securing the angle drive and adjust or shim up until the flight can fairly easily be rotated by hand.*

4. **Hydraulic Hose** –
Check hose and hose coupler frequently for leaks, wear or damage. Replace if necessary. Use cardboard when searching for leaks.

5. **Lift Cable** –
Check and replace if frayed or damaged. Make certain that cable clamps are secure.
6. **Cable Sheaves** –
Oil sheave pins on lift cylinder twice a year.
7. **Truss Cables** –
Adjust as needed to keep auger tube reasonably straight.
8. **Wheel Hubs** –
Repack every two or three years with lithium based grease.
9. **Tire Pressure** –
Check with a pressure gauge monthly or when pressure seems low. We recommend that pressure be maintained at 18 to 24 PSI (124 - 165 kPa).
10. **Hopper Lift Cable** –
Check and replace if frayed or damaged.
11. **Hopper Lift Cable Pulleys** –
Oil lightly several times a year for easier raising of hopper.
12. **Winch** –
Keep a film of grease on gears. Occasionally oil the bushings, drum shaft and ratchet.
13. **Optional Low Profile Hopper** –
Frequently: Loosen the two nuts securing the service door. Open door - then grease the four bushings and the two u-joints. Close door, then securely tighten the two 3/8" nuts.
Occasionally: Check and adjust the hopper drive chain and lubricate the hopper drive chain. To adjust chain, loosen the bearing bolts and adjust chain tension to about 1/4" deflection. **REPLACE SHIELD.**
14. **PTO Driveline** –
Lubricate all FIVE grease fittings regularly with good quality LITHIUM SOAP BASE E.P. GREASE meeting the NLGI #2 specifications and containing no more than 1% molybdenum disulfide. (Example: SHELL SUPER DUTY or EQUIVALENT)

Grease fittings No. 2 and 3 can be reached through hole in implement end portion of the driveline shield.

Grease fitting No. 4 can be reached through hole in center portion of the driveline shield.

The first lube interval should be 16-24 hours of operation after initial start-up, then follow the schedule.

** Constant angle applications must have lube interval of 4 hours.

CAUTION!!

REPLACEMENT PARTS ARE NOT LUBRICATED
Replacement parts must be lubricated at time of assembly. Use amount listed above per location, then follow lube recommendations outlined above for lubing intervals.

Ensure that the setscrews and shear-bolt are tight.

LUBE RECOMMENDATIONS

INTERVAL	LOCATION	AMOUNT
8 HRS.**	CROSS & BEARING	1 PUMP
8 HRS.	TELESCOPING MEMBERS	4-8 PUMPS
8 HRS.**	CV BALL & SOCKET	1-2 PUMPS

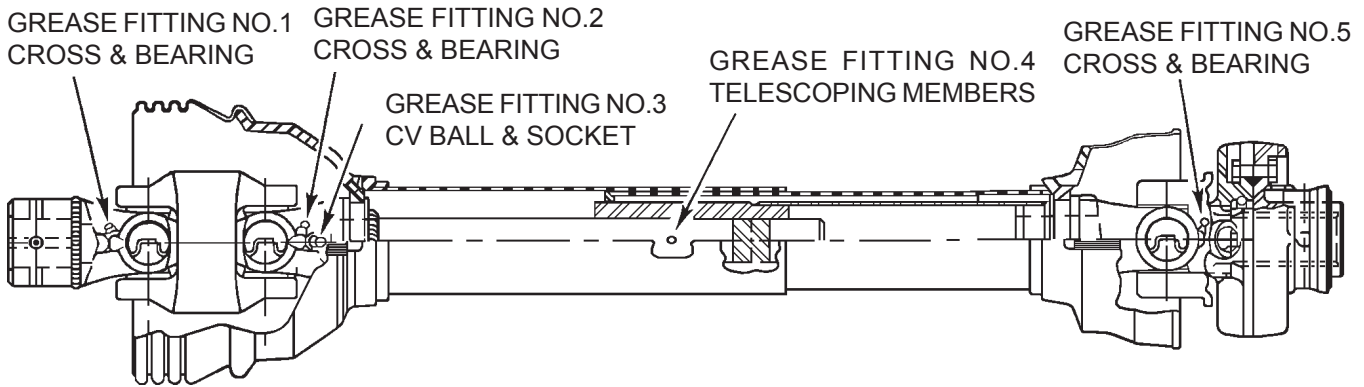

How to service **Mechanical Drive System:**

1. **Bottom Chain Drive –**
Keep drive chain tension adjusted to about 1/4" deflection by loosening the four bolts on lower bearing, then retighten. Oil chain frequently enough to keep film of oil on chain (this can be done through hole in top of sprocket shield). **REPLACE SPROCKET SHIELD AFTER MAINTENANCE.**
2. **Universal Joint –**
Flip up safety discharge door and lubricate grease fitting in the u-joint every 8 hours of operation. Check setscrews and retighten if necessary.
3. **Gearboxes –**
Check oil levels in both gearboxes at least once a year, depending on use. Gearboxes should be half full with EP90 lube oil. Fill as needed, you may need a flexible funnel.

If you notice excessive loss of oil, check more frequently and repair problem. Each gearbox requires 355 ml or 12-1/2 fluid ounces. Do not overfill, half full only.

- A. **Upper Gearbox -** flip up safety discharge door or open round service door and service gearbox as required.
- B. **Lower Gearbox -** open round service door and service gearbox as required.

For more extensive servicing or repairs, remove hopper from boot assembly by removing the 3/8" x 3/4" bolts and large washers. Lift hopper with front-end loader or other secure method (see **Figure No. 39**, page 48).

At this time also check and retighten setscrews and connecting bolts. Clean and lightly grease the splined

shaft. Reattach hopper to boot assembly as per instructions in **Section 3-11**.

4. Bearing --

Lubricate grease fitting on lower flight bearing. REPLACE SPROCKET SHIELD AFTER MAINTENANCE.

WARNING



DO NOT OPERATE AUGER WITH INTAKE HOPPER NOT IN PLACE. REPLACE AND SECURE SERVICE DOORS BEFORE OPERATING AUGER.

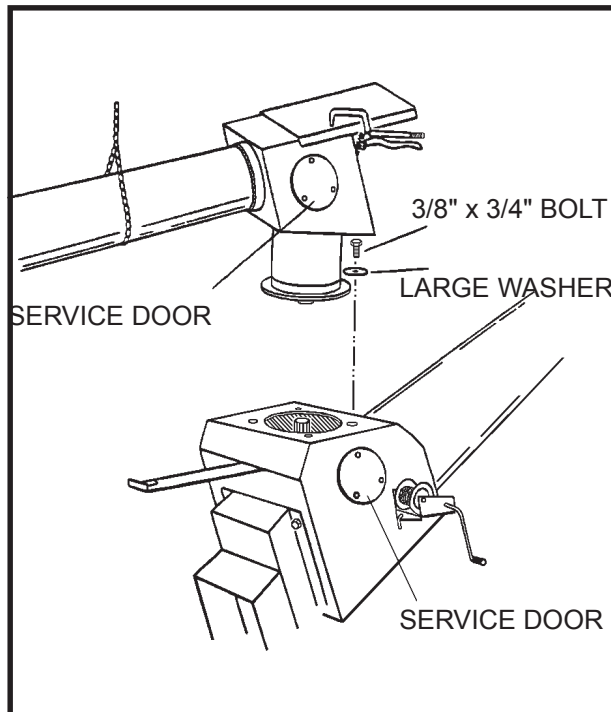

Figure No. 39

8-2. GENERAL STORAGE PROCEDURE

To protect auger in storage during the off-season, we suggest the following:

1. Lower the auger to full down position with slight tension on the cable.
2. Lubricate all grease fittings per maintenance procedure.

3. Inspect auger for damage and note any repairs required. Order replacement parts from your dealer.
4. Check tire pressure and inflate to 24 PSI (165 kPa).
5. Clean and re-lubricate the spline on PTO driveline. Cover PTO driveline with a plastic bag to protect it from the weather and place it in the transport saddle.
6. Tow auger to storage area. Park and chock wheels.

DANGER



WATCH FOR OVERHEAD ELECTRICAL WIRES. ELECTROCUTION CAN OCCUR WITHOUT DIRECT CONTACT. FAILURE TO HEED THIS WARNING WILL RESULT IN SERIOUS INJURY OR DEATH.

CAUTION



SUPPORT DISCHARGE END OF AUGER BEFORE REMOVING OR REPLACING ANY PARTS ON THE UNDERCARRIAGE.

To prepare auger for use after storage, we recommend the following:

1. Check tire pressure and inflate to 24 PSI (165 kPa) if necessary.
2. Tow auger to worksite, being mindful of electrical wires overhead. **(See chapter 4 on page 32 for correct procedure.)**
3. Remove waterproofing from spline of PTO driveline and re-lubricate.
4. Replace any damaged parts and decals.
5. Conduct general maintenance procedure before using auger.

6. Before raising auger after storage, make certain cable is in good condition, replacing it if frayed or damaged. In addition, ensure that cable is properly seated in cable sheaves on lift cylinder and that cable clamps are secure.

Use only genuine WESTFIELD replacement parts or equivalent. Replacement parts such as intake shields, pulley shields, PTO driveline shields, winches and lift cables MUST MEET ASAE Standards or serious injury may result. Use of unauthorized parts will void warranty. If in doubt, contact WESTFIELD or your WESTFIELD dealer. Do not modify any auger components.

9. Index

Assembly	11		
Access Cover	25,26	Under Tube Truss	16,18
Angle Drive	25	Universal Joints	26
Angle Ring Support Bracket.....	14	Upper Liftarms	20
Auger/Tractor Hook-up	28,29	Wheels/Tires	20
Axle Extension.....	37	Wheels/Hopper	25
Boot	15	Anchor Bracket	16,17
Discharge Door, Safety	26	Auger Drive and Lockout	37
Flat Braces	21	Auger/Tractor Hook-up	28
Flighting	11		
Frame Bushings.....	19	Boot Assembly	15
Frame Corner Brace.....	20	Break-in/Start Up	39
Gearbox	15,25,47		
Gearbox Enclosure	26	Checklists	
Hitch Jack	28	Hydraulic Safety	6
Hitch Pin	30,33	Maintenance Safety	6
Hopper Flighting	25	Operational Safety	3
Hydraulic Hose	27	Pre-Operational	38
Hydraulic Hose Couplers	30	Pre-Transport	33
Intake Feed Hopper	25	Transport and Placement Safety	5
Large Washers	26	Completion/Clean-up	41
Liftarm, Hopper	27	Contents, Table of	1
Liftcable	22	Crossmember, Long	20
Lift Cylinder	22	Crossmember, Short	20
Lift Extension.....	25	Cylinder Hydraulics, Lift	43
Lower Reach-Arms	20	Cylinder Installation, Lift	22
PTO Driveline	23		
Ram Guide.....	22	Decals, Safety	6, 7, 8, 9, 10
Roller Chain	16		
Roller Trackshoe	13	Emergency Shut-down	40
Rubber Extension	26		
Saddle, Transport	24,28	Flighting Assembly	11
Safety Discharge Door	26	Full Load Procedure	40
Sprockets	15		
Sprocket Cover	16,24	Gearbox	15,25,47
Stabilizer Assembly	21	Gearbox Enclosure	26
Swivel Ring	26		
Track Stop, Angle	13	Hitch Jack Installation	28,33
Trackshoe, Roller	13	Hopper Liftarm/Winch Assembly	27
Transport Saddle	24,28	Hydraulics	43
Trussing	16	General Information	43
Tube	11	Hose	43
Tubing Cross Braces	22	Hydraulic Fluid Requirements	44
Undercarriage	19,20	Lift Cylinder	43
		PSI Requirements	432
		Safety	6

Index	51	Full Load	40
Intake Feed Hopper	25	Lockout/Shut-down	39
Introduction	2	Lowering Auger	41
Jack Installation, Hitch	28	Maintenance	47
Liftcable Installation	22	Placement	36
Lift Cylinder Hydraulics	43	Pre-Placement	35
Lift Cylinder Installation	22	Start-Up and Break-in	39
Lock-out, Auger	39	Shut-Down, Normal/Emergency	40
Lowering Procedure	41	Storage	47
		Transport	33
		PSI Requirements	43
		PTO Driveline, Operation of	38
		PTO Driveline	23,28,38
Maintenance Storage	47	Safety First	3
Chain Drive	48	Decals	6, 7, 8, 9, 10
General Maintenance Procedure	47	Hydraulics	6
General Storage Procedure	49	Maintenance	6
Gearboxes, Upper/Lower	48	Operational	3
Hopper Liftcable	47	Transport Hazard Zone	5
Hydraulic Hose	47	Transport and Placement	5
Liftcable	47	Work Area and Hazard Zone	4
PTO Driveline	47	Sign Off Form	Inside Front Cover
Safety	6	Stabilizer Braces	21
Sheaves, Cable	47	Start-Up and Break-in	39
Shutdown, Normal/Emergency	40		
Truss Cables	47	Table of Contents	1
Tire Pressure	47	Tire Installation	20
Wheel Hubs	47	Track Stop Installation	13
Winch	47	Trackshoe Installation	13
		Transport	33
Operation	38	Hazard Zone	5
Auger Drive and Lockout	38	Pre-Transport Checklist	33
Completion/Clean-Up	41	Safety	5
Full Load Procedure	40	Transport Procedure	34
Lowering Procedure	41	Trussing Installation	16
Normal/Emergency Shut-Down	40	Tube Assembly	11
Grain Overflow	40	Table I	29
Safety	3		
Pre-Operational Checklist	38	Under Carriage Assembly	19
Start-Up and Break-in	39	Under Carriage Installation	20
		Universal Joints	26
Placement	35		
Placement Procedure	36	Warranty	Inside Back Cover
Pre-Placement Procedure	35	Wheels, Hopper	25
Safety	5	Wheels, Carriage	20
Procedures		Work Area Hazard Zone	4
Completion/Clean-Up	41		



WARRANTY

Westfield Industries Ltd. warrants products of its manufacture against defects in materials or workmanship under normal and reasonable use for a period of one year after date of delivery to the original purchaser.

Our obligation under this warranty is limited to repairing, replacing, or refunding defective part or parts which shall be returned to a distributor or a dealer of our Company, or to our factory, with transportation charges prepaid. This warranty does not obligate Westfield Industries Ltd. to bear the cost of labor in replacing defective parts. Any defects must be reported to the Company before the end of the one year period.

This warranty shall not apply to equipment which has been altered, improperly assembled, improperly maintained, or improperly repaired so as to adversely affect its performance. Westfield Industries Ltd. makes no express warranty of any character with respect to parts not of its manufacture.

The foregoing is in lieu of all other warranties, expressed or implied, including any warranties that extend beyond the description of the product, and the IMPLIED WARRANTY of MERCHANTABILITY is expressly excluded.

WESTFIELD INDUSTRIES LTD.
ROSENORT, MANITOBA
CANADA
ROG 1WO

WESTFIELD[®]

INDUSTRIES

A Division of Ag Growth Industries Limited Partnership

ROSENORT, MANITOBA, CANADA

R0G 1W0

(204) 746-2396

visit us at: www.grainaugers.com
e-mail us at: admin@westfieldindustries.com