

# WESTFIELD®

## REMOTE POWERSWING

A232, A233, A234, A235, AND A236 MODELS  
ASSEMBLY AND OPERATION MANUAL

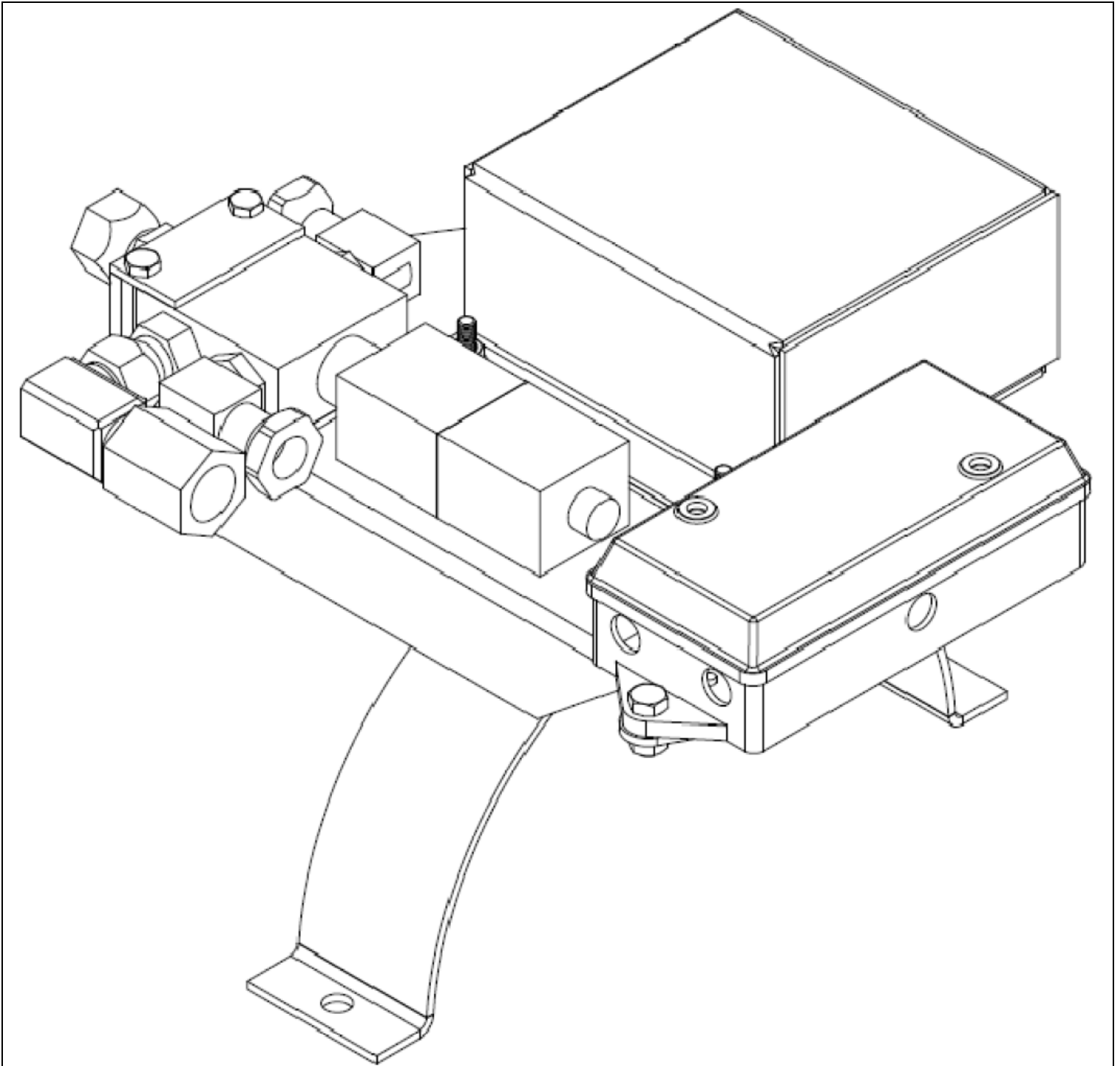

Read this manual before using product. Failure to follow instructions and safety precautions can result in serious injury, death, or property damage. Keep manual for future reference.

Part Number: 30663 R0

Revised: 5/2/10



# TABLE OF CONTENTS

<b>2. Safety First</b> .....	<b>5</b>
2.1. General Safety .....	6
<b>3. Assembly</b> .....	<b>9</b>
3.1. Remote Mount Installation.....	9
3.2. Hydraulic Configuration .....	10
3.3. Antenna Preparation .....	11
<b>4. Operation</b> .....	<b>13</b>
<b>5. Maintenance</b> .....	<b>15</b>
<b>6. Troubleshooting</b> .....	<b>17</b>
<b>7. Appendix</b> .....	<b>19</b>
7.1. Remote Coding .....	19
Warranty.....	21



# 2. Safety First



The Safety Alert symbol to the left identifies important safety messages on the product and in the manual. When you see this symbol, be alert to the possibility of personal injury or death. Follow the instructions in the safety messages. Why is SAFETY important to you?

Three big reasons:

- Accidents disable and kill.
- Accidents cost.
- Accidents can be avoided.

## SIGNAL WORDS

Note the use of the signal words **DANGER**, **WARNING**, **CAUTION**, and **NOTICE** with the safety messages. The appropriate signal word for each message has been selected using the definitions below as a guideline.

The Safety Alert symbol means ATTENTION, BE ALERT!, YOUR SAFETY IS INVOLVED.

### DANGER



Indicates an imminently hazardous situation that, if not avoided, will result in serious injury or death.

### WARNING



Indicates a hazardous situation that, if not avoided, could result in serious injury or death.

### CAUTION



Indicates a hazardous situation that, if not avoided, may result in minor or moderate injury.

### NOTICE

Indicates a potentially hazardous situation that, if not avoided, may result in property damage.

## 2.1. GENERAL SAFETY

**Important:** *The general safety section includes instructions that apply to all safety practices. Any instructions specific to a certain safety practice (e.g., assembly safety), can be found in the appropriate section. Always read the complete instructional sections and not just these safety summaries before doing anything with the equipment.*

**YOU** are responsible for the **SAFE** use and maintenance of your equipment. **YOU** must ensure that you and anyone else who is going to work around the equipment understands all procedures and related **SAFETY** information contained in this manual.

Remember, **YOU** are the key to safety. Good safety practices not only protect you, but also the people around you. Make these practices a working part of your safety program.

- It is the equipment owner and the operator's responsibility to read and understand **ALL** safety instructions, safety decals, and manuals and follow them before assembling, operating, or maintaining the equipment. All accidents can be avoided.
- Equipment owners must give instructions and review the information initially and annually with all personnel before allowing them to operate this product. Untrained users/operators expose themselves and bystanders to possible serious injury or death.
- Use this equipment for its intended purposes only.
- Do not modify the equipment in any way. Unauthorized modification may impair the function and/or safety, and could affect the life of the equipment. Any modification to the equipment voids the warranty.
- Do not allow children, spectators, or bystanders within the work area.
- Have a first-aid kit available for use should the need arise, and know how to use it.
- Provide a fire extinguisher for use in case of an accident. Store in a highly visible place.
- Wear appropriate protective gear. This list includes, but is not limited to:
  - a hard hat
  - gloves
  - protective shoes with slip-resistant soles
  - protective goggles
  - hearing protection
- For Powered Equipment: before servicing, adjusting, or repairing powered equipment, unplug, place all controls in neutral or off position, stop the engine or motor, remove ignition key or lock out power source, and wait for all moving parts to stop.



- Follow good shop practices:
  - keep service area clean and dry
  - be sure electrical outlets and tools are properly grounded
  - use adequate light for the job at hand
  - Think SAFETY! Work SAFELY!





# 3. Assembly

The manual for the Hydraulic Powerswing is included with this kit and installing the Remote Powerswing will follow all the same steps with a few additional steps that must be completed first. Be sure to read this insert over PRIOR to assembly to insure correct assembly order.

**Note:** *If not using the 7-pin electrical connector supplied with the Powerswing, be sure to note that the white wire of this cable is to be connected to a ground and the black wire is to be connected to a 12- to 15-V source. It is strongly recommended you get a qualified professional to ensure proper wiring.*

## NOTICE

Failure to connect the wires in polarity described will result in unsafe operation and can cause undesirable effects such as failure of the remote to function.

## 3.1. REMOTE MOUNT INSTALLATION

The Remote Powerswing Retrofit is designed to allow the Hydraulic Powerswing to function via remote. To install, follow the steps below and refer to Figure 3.1 and Figure 3.3.

1. **Retrofit Only:** Disconnect the hydraulic hoses from the old hydraulic valve.
2. **Retrofit Only:** Unbolt the old valve from the mount.
3. Place one of the supplied spacers on each of the three bolts on the lower side of the Remote Retrofit mount (see Figure 3.1).
4. Re-attach to the original valve mount.
5. Connect the hydraulic hoses to the new valve.

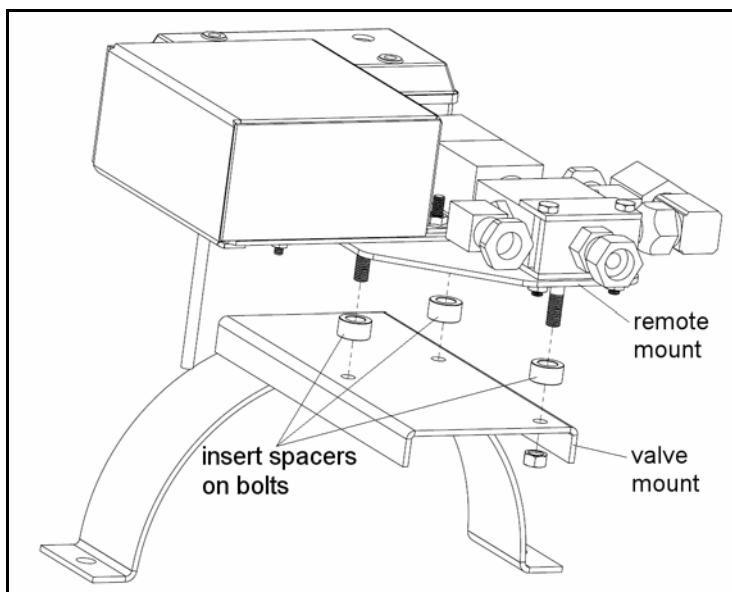

Figure 3.1

## 3.2. HYDRAULIC CONFIGURATION

This valve is designed to be used with tractors / hydraulic pumps that operate in open loop format or with CLLS (Closed Loop Load Sensing) with simple modifications. If you are unsure of your hydraulic configuration it is recommended you contact your tractor dealer to inquire. If you are unable to determine hydraulic pump configuration, we recommend installing the valve in the Open Loop configuration.

When shipped, the valve will be set-up for Open Loop usage. Should you require the **valve set-up for CLLS**, follow these steps and refer to Figure 3.3.

1. Use two 7/16" wrenches to loosen the two 1/4" bolts holding the valve on.
2. Lift the valve, bolts, and spacers from the mount as one, rotate it 180° as shown in Figure 3.3.
3. Insert the bolts into the second set of holes and retighten.

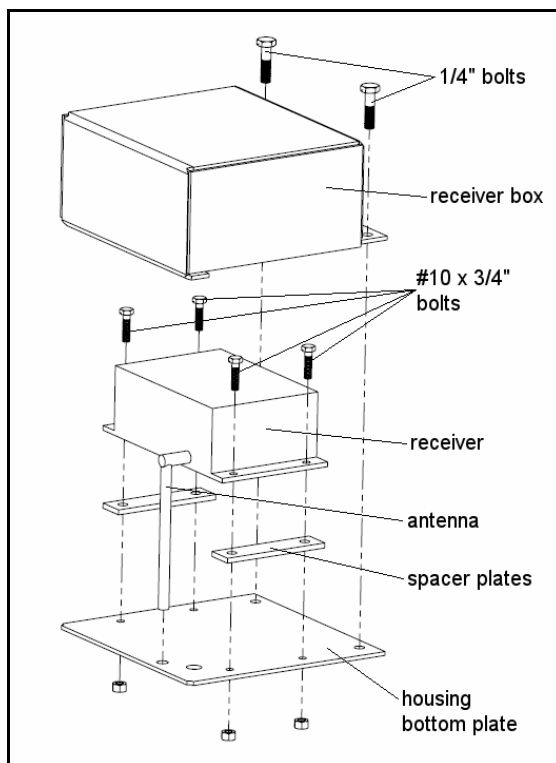

Figure 3.2

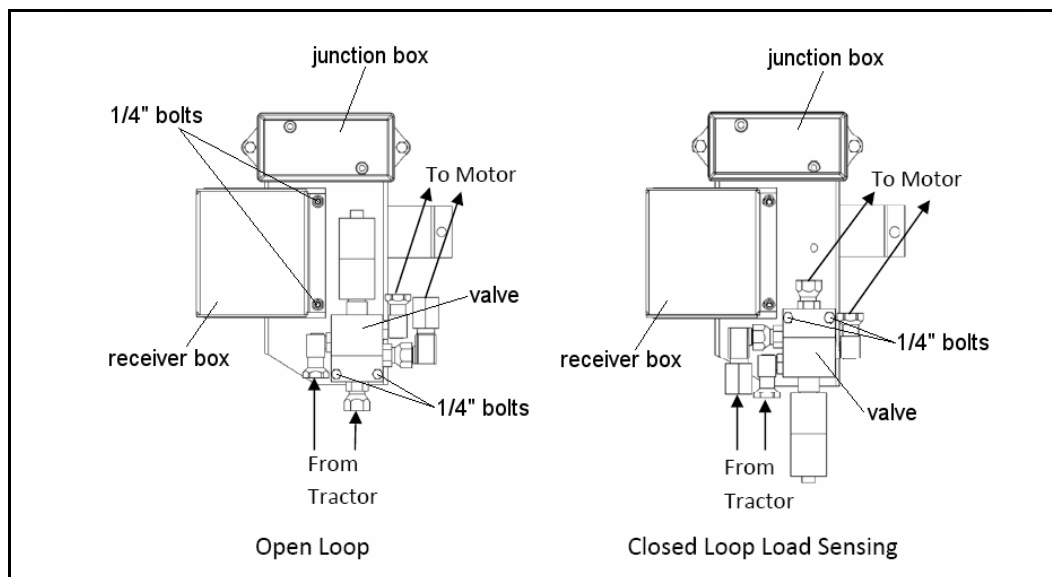

Figure 3.3

**Note:** There are 2 sets of holes into which to bolt the valve. When shipped, the valve will be bolted through the holes closest to the end of the mount. When switching to CLLS, you must use the other set of holes that are closer to the center of the mount.

**Note:** When rotating the valve, the wires may become too short. If this occurs open the junction box lid and slide extra wire out.

## 3.3. ANTENNA PREPARATION

When shipped, the antenna for the Remote Powerswing receiver will be within its protective steel housing. The antenna must be positioned outside of the housing (Figure 3.2) in order to get proper reception. Follow the steps below to adjust.

1. Use two 7/16" wrenches to unbolt the two 1/4" bolts holding the protective receiver box onto the mount plate (see Figure 3.2).
2. Slide the receiver box off of the housing.
3. Use a hex head wrench and screwdriver to remove the four #10 x 3/4" bolts securing the receiver to the housing bottom plate.
4. Turn the antenna downward and feed it through the appropriate hole in the housing bottom plate.

**Note:** Section 7. Appendix on page 19 can be completed conveniently here.

5. Re-fasten the receiver to the bottom plate making sure to use the spacer plates as they were installed before.
6. Slide the receiver box back on and bolt the assembly back to the mount.

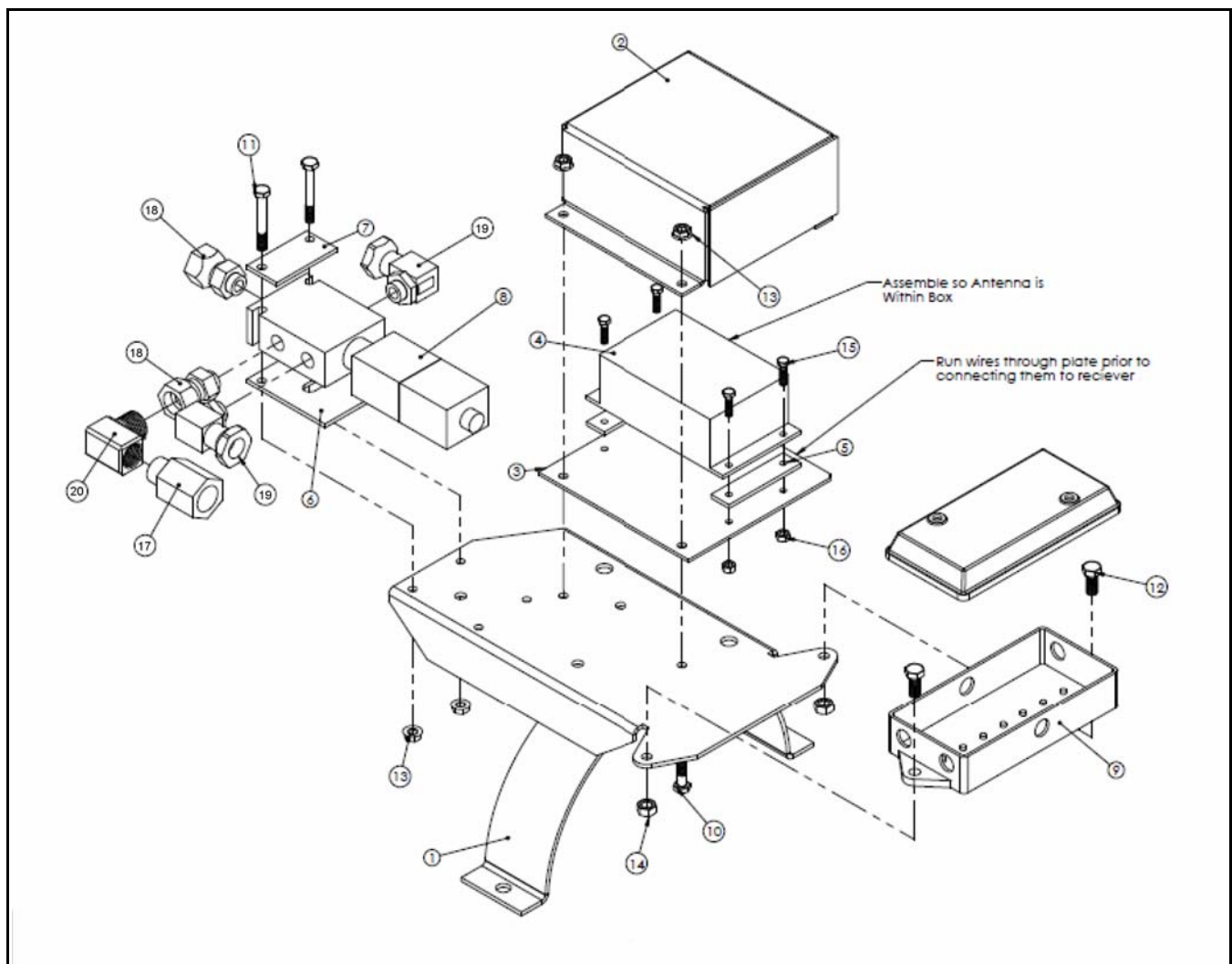

Figure 3.4 Remote Powerswing Complete Assembly

**Table 3.1**

ITEM	PART NO.	DESCRIPTION	ITEM	PART NO.	DESCRIPTION
1	16422	Remote Powerswing Mount 10"	11	28725	Bolt, 1/4" x 2" GR5 PLTD
2	16420	Receiver Box Cover	12	19538	Bolt, 5/16" x 3/4" GR2 PLTD
3	51354	Receiver Housing Bottom Plate	13	19594	Flange Nut, 1/4" PLTD
4	28650	Remote Receiver Box	14	19980	Nut, Nylock 5/16" PLTD
5	51357	Spacer Plate	15	28656	Bolt, #10 x 3/4" GR2 PLTD
6	51351	Electro-Hydraulic Valve Spacer	16	28657	Nut, Nylock #10 PLTD
7	51352	Electro-Hydraulic Valve Retainer	17	28315	Orifice - Drilled 3/8" Pipe Plug
8	28651	Electro-Hydraulic 4-Way Valve	18	28477	#8 ORB - 1/2" FNPT Adapter
9	28652	Junction Box	19	28654	#8 ORB - 1/2" FNPT 90° Adapter
10	19988	Bolt, 1/4" x 1" GR2 PLTD	20	12360	1/2" Brass Elbow

# 4. Operation

The hand held transmitter has 8 buttons on it but only 2 are needed. To operate the swing, press the green "on" button in rows 1 and 2. These will be the only buttons that will move the swing.

**Note:** *If desired, the direction of movement when pressing each button can be reversed by reversing the connection of the two hoses to the tractor. To change the direction of movement using the manual switch located in the junction box, rotate the switch in the box.*

It is important to locate the remote such that the buttons cannot be pressed accidentally. Carry and handle the remote in a way to avoid accidental depression at all times.

## WARNING

If the swing is operated accidentally, serious injury to unsuspecting bystanders and/or damage to the auger can occur.



# 5. Maintenance

The Remote Powerswing can be exposed to some poor conditions during normal usage. Following the annual maintenance schedule of the electronic components below will assure a long life of operation.

1. Open the junction box and check for corrosion and assure all connections are tight (see Figure 6.1).
2. Use an air gun to blow any dust and dirt out of the box.
3. Reapply corrosion-inhibiting paste as needed to the terminals.
4. Open the steel receiver housing and inspect for corrosion, dust, and dirt.
5. Open the plastic receiver and inspect, checking the circuit board for corrosion.
6. Use an air gun to blow any dust or dirt from the housing and reassemble.

**Note:** *Batteries may need to be inspected and/or replaced. Most hardware and general retail stores can identify the battery type and carry replacements.*



# 6. Troubleshooting

Problem	Possible Cause	Remedy
<b>Hand held transmitter does not work.</b>	Error with coding the transmitter or receiver.	Verify that coding is correct (see Section 7. Appendix on page 19). Contact a Westfield customer service representative if problem persists.
<b>Manual switch does not work.</b>	Incorrect or faulty wiring of the switch.	Verify that wiring to switch is correct (see Section 3.2. Hydraulic Configuration on page 10). If problem persists, replace switch.
<b>Valve only works in one direction.</b>	Incorrect wiring of the switch. *Incorrect wiring may also blow the fuse in the junction box.	Verify that valve is wired correctly (see Section 3.2. Hydraulic Configuration on page 10).
<b>Manual switch and transmitter do not work in either direction.</b>	Power not reaching junction box (white light on the manual switch does not illuminate).	<ul style="list-style-type: none"> <li>• Remove and insert the 7-pin connector from the tractor to ensure a good connection.</li> <li>• Verify the solid connection of the power supply wire in the junction box of the Powerswing.</li> <li>• Open the 7-pin connector and verify that the black wire is attached securely to the terminal labelled "blue", and the white wire to the terminal labelled "white".</li> </ul>
	Power reaching junction box (white light on the manual switch is illuminated).	<ul style="list-style-type: none"> <li>• Open the junction box and check the 10-amp fuse. Replace if there is any doubt of its condition.</li> <li>• Verify that the manual switch is wired correctly (see Section 3.2. Hydraulic Configuration on page 10). If wired incorrectly, it can override all functions.</li> <li>• Verify that the valves are wired correctly (see Section 3.2. Hydraulic Configuration on page 10).</li> </ul>

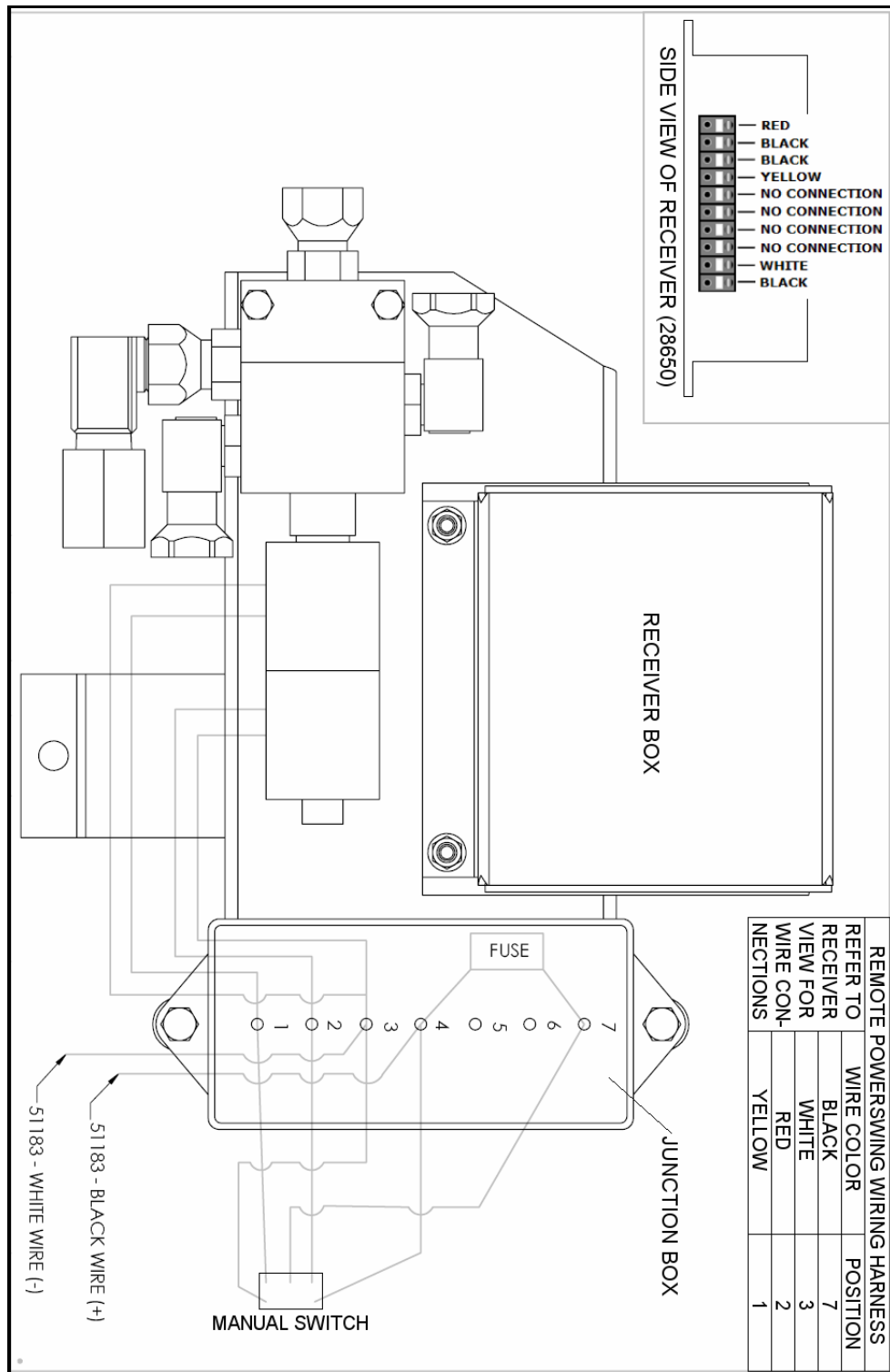

**Figure 6.1 Powerswing Wiring Schematic**

# 7. Appendix

## 7.1. REMOTE CODING

---

For the remote to function correctly the receiver and transmitter must use the same code. The code on both the transmitter and receiver can be changed independently. The transmitter and receiver come from the factory pre-coded, but while assembling, the coding of both the transmitter and the receiver should be checked.

**Important:** *The transmitter and receiver use different numbering for the switches. For simplicity, set the receiver and record the positions in Table 7.1 to reference when setting the transmitters.*

Check the coding by confirming that the same switches are turned "on" for the transmitter and the receiver by following the instructions below.

### RECEIVER

The coding switches are located on the side of the receiver (Figure 7.1) under the protective steel cover.

1. Record the position of all the switches in Table 7.1.

**Note:** *When a switch is in the down position it is referred to as "on".*

### HAND HELD TRANSMITTER

The coding switches on the transmitter are hidden behind a removable snap in cover on the back of the device (Figure 7.1).

2. Use a small screwdriver to pry the cover off the side of the transmitter.
3. Switches A9 and A0 on the receiver should always be in the "off" position or the transmitter will not work.
4. Match the remainder of the switches to the receiver. When a switch is in the location closest to the belt clip, it is "on". The position closer to the edge of the remote is "off".

**Note:** *To control the same receiver with multiple transmitters requires that all transmitters have the same coding. Simply adjust the coding of any new transmitter to the coding of your receiver and it will be ready for use.*

**Important:** *The transmitter and receiver use different numbering for the switches. For simplicity, set the receiver and record the positions in Table 7.1 to reference when setting the transmitters.*

**Table 7.1**

Switch Cross-Reference			
Switch Name	Receiver Switch	Transmitter Switch	Record Your Receiver Coding
A9	—	10	OFF
A8	—	9	OFF
A7	1	8	
A6	2	7	
A5	3	6	
A4	4	5	
A3	5	4	
A2	6	3	
A1	7	2	
A0	8	1	

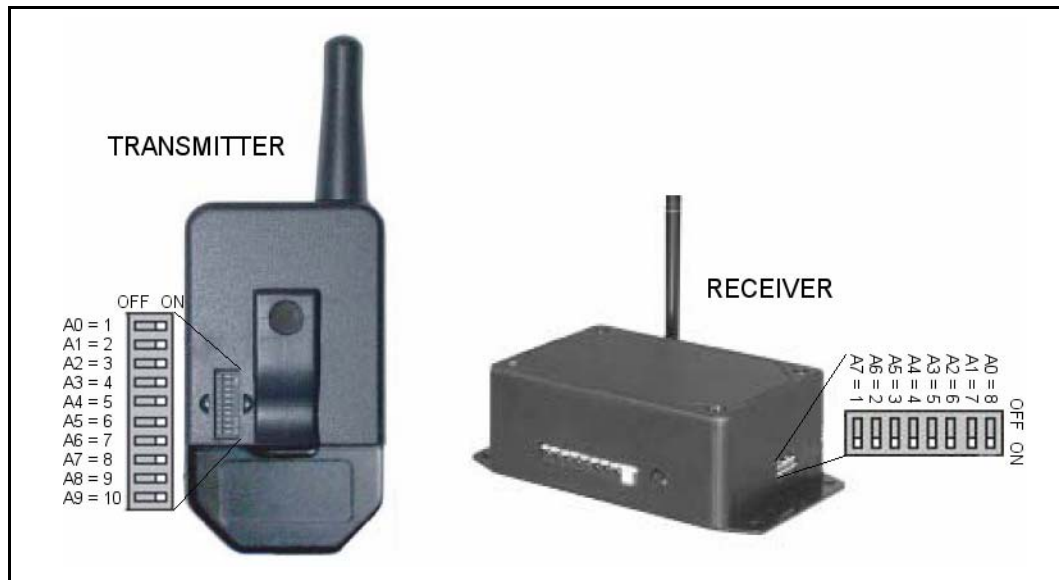

**Figure 7.1**

# WARRANTY

Westfield Industries Ltd. warrants products of its manufacture against defects in materials or workmanship under normal and reasonable use for a period of one year after date of delivery to the original purchaser.

Our obligation under this warranty is limited to repairing, replacing, or refunding defective part or parts which shall be returned to a distributor or a dealer of our Company, or to our factory, with transportation charges prepaid. This warranty does not obligate Westfield Industries Ltd. to bear the cost of labor in replacing defective parts. Any defects must be reported to the Company before the end of the one year period.

This warranty shall not apply to equipment which has been altered, improperly assembled, improperly maintained, or improperly repaired so as to adversely affect its performance. Westfield Industries Ltd. makes no express warranty of any character with respect to parts not of its manufacture.

The foregoing is in lieu of all other warranties, expressed or implied, including any warranties that extend beyond the description of the product, and the IMPLIED WARRANTY of MERCHANTABILITY is expressly excluded.

WESTFIELD INDUSTRIES LTD.

ROSENORT, MANITOBA

CANADA

ROG 1W0

## ***WESTFIELD***

Westfield is a Division of Ag Growth Industries LP

Part of the Ag Growth International Inc. Group

P.O. Box 39

Rosenort, Manitoba, Canada R0G 1W0

Phone: (866) 467-7207 (Canada & USA)

Fax: (866) 768-4852

website: [www.grainaugers.com](http://www.grainaugers.com)

email: [sales@grainaugers.com](mailto:sales@grainaugers.com)

© Ag Growth Industries Limited Partnership 2009

Printed in Canada