

# WESTFIELD®

## BELT CONVEYOR

WC1335

### ASSEMBLY & OPERATION MANUAL



Read this manual before using product. Failure to follow instructions and safety precautions can result in serious injury, death, or property damage. Keep manual for future reference.

Part Number: 30424 R0

Revised: 16/2/11



# TABLE OF CONTENTS

<b>1. Introduction .....</b>	<b>5</b>
<b>2. Safety First.....</b>	<b>7</b>
2.1. General Safety .....	8
2.2. Operation Safety .....	9
2.3. Hydraulic Safety .....	11
2.4. Electric Motor Safety .....	11
2.5. Transport and Placement Safety .....	11
2.6. Maintenance Safety.....	12
2.7. Safety Decal Locations.....	12
2.7.1. Decal Installation .....	12
2.7.2. Decal Locations .....	13
<b>3. Assembly .....</b>	<b>15</b>
3.1. Conveyor Tube .....	15
3.2. Intake Hopper Assembly .....	18
3.3. Spout Hood Installation .....	21
3.4. Electric Motor Drive (Option A).....	22
3.5. Hydraulic Drive (Option B).....	24
3.6. Track Shoe and Cable.....	24
3.7. Transport Undercarriage .....	26
3.8. Model Decal Placement .....	29
3.9. Plastic Manual Holder .....	30
<b>4. Transport &amp; Placement .....</b>	<b>31</b>
4.1. Transport .....	31
4.1.1. Pre-Transport Checklist.....	31
4.1.2. Transport Procedure.....	31
4.2. Placement Procedure .....	32
4.2.1. Under Hopper Bottom Bins.....	32
4.2.2. Filling Bins .....	32
<b>5. Operation .....</b>	<b>35</b>
5.1. Pre-Operation Checklist .....	35
5.2. Machine Break-In And Operation .....	35
5.2.1. Drive Setup .....	36
5.2.2. Starting Conveyor .....	36
5.2.3. Conveyor Shutdown .....	37
5.2.4. Emergency Shutdown .....	37
5.2.5. Re-starting (Full Tube).....	37
5.2.6. Conveyor Operating Angles .....	37
5.2.7. Belt Speed .....	38
5.2.8. Operating Tips .....	38

# TABLE OF CONTENTS

<b>6. Maintenance &amp; Storage</b> .....	<b>39</b>
6.1. Maintenance Schedule .....	39
6.1.1. Initial start-up servicing .....	39
6.1.2. 8 Hours or Daily .....	39
6.1.3. 40 Hours or Weekly .....	39
6.1.4. 200 Hours or Annually .....	39
6.2. Maintenance Checklist .....	40
6.3. Service & Maintenance Procedures .....	41
6.3.1. Fluids and Lubricants.....	41
6.3.2. Greasing .....	41
6.3.3. Conveyor Belt Tension .....	41
6.3.4. Conveyor Belt Alignment .....	42
6.3.5. Conveyor Belt Replacement.....	44
6.3.6. Belt Relacing.....	44
6.3.7. Drive Belt Tension & Alignment (Electric Drive) .....	45
6.4. Storage Procedure .....	46
<b>7. Troubleshooting</b> .....	<b>47</b>
<b>8. Appendix</b> .....	<b>49</b>
8.1. Conveyor Product Chart.....	49
8.2. Other Specifications .....	50
Warranty.....	51

# 1. Introduction

Congratulations. As the new owner of a Westfield belt conveyor, you will be working with equipment designed to complement and improve your farming operation. Before using this conveyor, please read this manual and familiarize yourself with the various features of the machine and the necessary precautions for efficient and safe operation.

In addition, anyone using this conveyor is required to be familiar with all safety precautions. A sign-off form is supplied on the inside front cover to record your safety reviews.

Thank you.



<b>Serial Number:</b>	
*Located on the lower tube.	



# 2. Safety First



The Safety Alert symbol to the left identifies important safety messages on the product and in the manual. When you see this symbol, be alert to the possibility of personal injury or death. Follow the instructions in the safety messages. Why is SAFETY important to you?

Three big reasons:

- Accidents disable and kill.
- Accidents cost.
- Accidents can be avoided.

## SIGNAL WORDS

Note the use of the signal words **DANGER**, **WARNING**, **CAUTION**, and **NOTICE** with the safety messages. The appropriate signal word for each message has been selected using the definitions below as a guideline.

The Safety Alert symbol means: "ATTENTION, BE ALERT! YOUR SAFETY IS INVOLVED".

<b>DANGER</b>	
	Indicates an imminently hazardous situation that, if not avoided, will result in serious injury or death.
<b>WARNING</b>	
	Indicates a hazardous situation that, if not avoided, could result in serious injury or death.
<b>CAUTION</b>	
	Indicates a hazardous situation that, if not avoided, may result in minor or moderate injury.
<b>NOTICE</b>	
	Indicates a potentially hazardous situation that, if not avoided, may result in property damage.

## 2.1. GENERAL SAFETY

**Important:** *The general safety section includes instructions that apply to all safety practices. Any instructions specific to a certain safety practice (e.g., assembly safety), can be found in the appropriate section. Always read the complete instructional sections and not just these safety summaries before doing anything with the equipment.*

**YOU** are responsible for the **SAFE** use and maintenance of your equipment. **YOU** must ensure that you and anyone else who is going to work around the equipment understands all procedures and related **SAFETY** information contained in this manual.

Remember, **YOU** are the key to safety. Good safety practices not only protect you, but also the people around you. Make these practices a working part of your safety program.

- It is the equipment owner and the operator's responsibility to read and understand **ALL** safety instructions, safety decals, and manuals and follow them before assembling, operating, or maintaining the equipment. All accidents can be avoided.
- Equipment owners must give instructions and review the information initially and annually with all personnel before allowing them to operate this product. Untrained users/operators expose themselves and bystanders to possible serious injury or death.
- Use this equipment for its intended purposes only.
- Do not modify the equipment in any way. Unauthorized modification may impair the function and/or safety, and could affect the life of the equipment. Any modification to the equipment voids the warranty.
- Do not allow children, spectators, or bystanders within the work area.
- Have a first-aid kit available for use should the need arise, and know how to use it.
- Provide a fire extinguisher for use in case of an accident. Store in a highly visible place.
- Wear appropriate protective gear. This list includes, but is not limited to:
  - a hard hat
  - gloves
  - protective shoes with slip-resistant soles
  - protective goggles
  - hearing protection
  - dust mask or respirator
- For Powered Equipment: before servicing, adjusting, or repairing powered equipment, unplug, place all controls in neutral or off position, stop the engine or motor, remove ignition key or lock out power source, and wait for all moving parts to stop.



- Follow good shop practices:
  - keep service area clean and dry
  - be sure electrical outlets and tools are properly grounded
  - use adequate light for the job at hand
  - Think SAFETY! Work SAFELY!



## 2.2. OPERATION SAFETY

---

- Always work with a second person around conveyors in case of accident.
- Inspect lift cable before using conveyor. Replace if frayed or damaged.
- Properly seat lift cable in cable pulleys.
- Lock winch before operating conveyor.
- Do not modify the equipment in any way. Unauthorized modification may impair the function and/or safety, and could affect the life of the equipment.
- Empty conveyor before raising or lowering.
- Stay away from overhead obstructions and power lines when operating and transporting. Electrocutation can occur without direct contact.
- Do not operate conveyor with any of the safety guards removed.
- Keep body, hair, and clothing away from moving parts.
- Operate conveyor on level ground free of debris. If ground is uneven, anchor the conveyor to prevent tipping or upending.
- Anchor or support discharge end to further stabilize conveyor and prevent tipping.
- Lower conveyor at completion of operation or when not in use. Check winch cable for damage.
- Do not get on or beneath conveyor when raising or lowering.

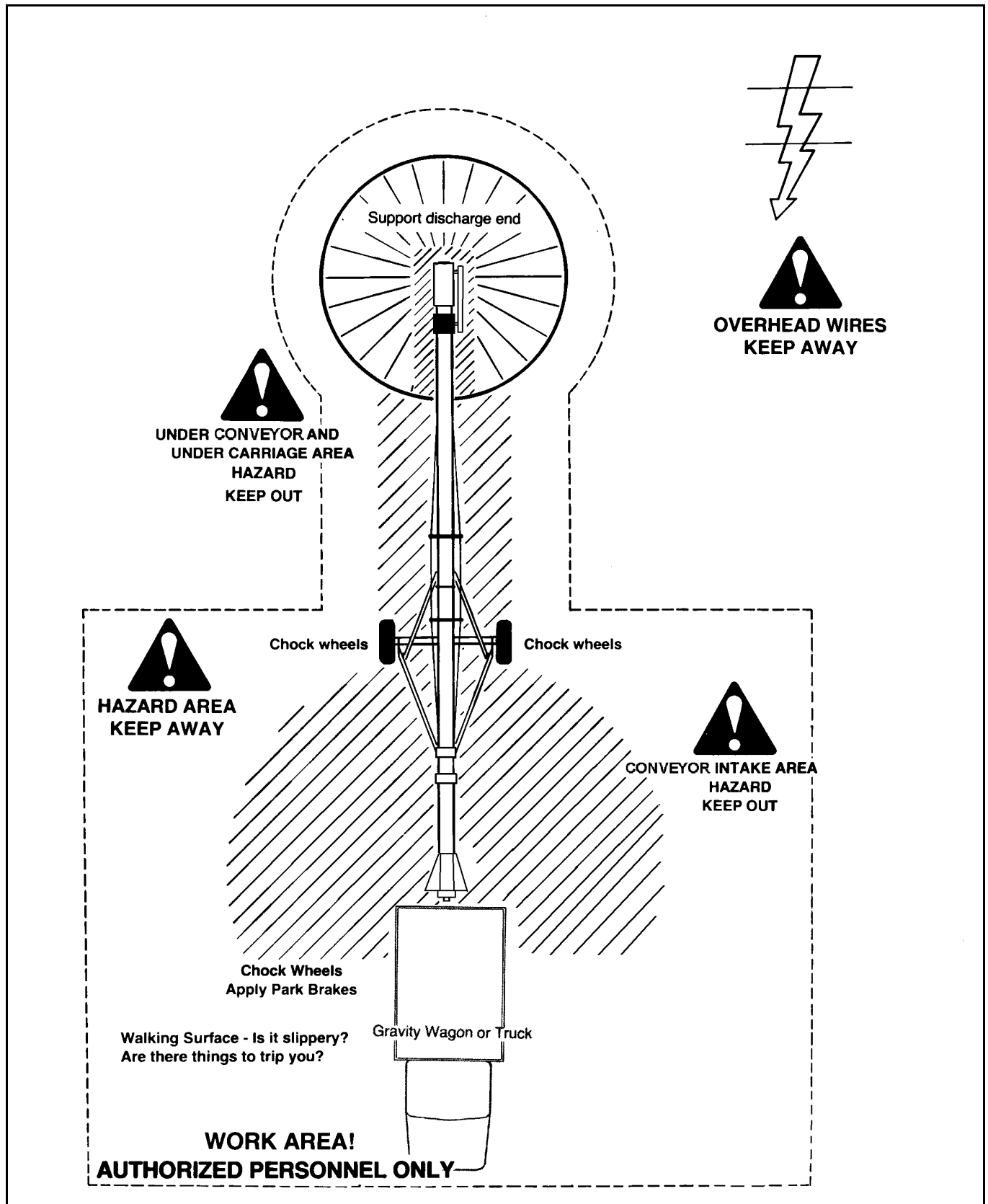
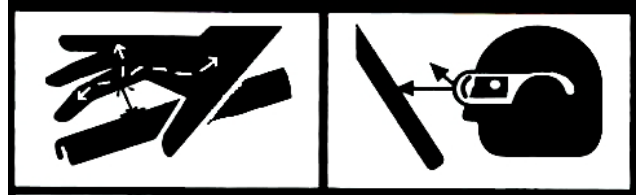

Figure 2.1

## 2.3. HYDRAULIC SAFETY

---

- Always place all tractor hydraulic controls in neutral before disconnecting from tractor or working on hydraulic system.
- Make sure that all components in the hydraulic system are kept in good condition and are clean.
- Replace any worn, cut, abraded, flattened, or crimped hoses.
- Do not attempt any makeshift repairs to the hydraulic fittings or hoses by using tape, clamps, or cements. The hydraulic system operates under extremely high-pressure. Such repairs create a hazardous and unsafe condition because they will fail suddenly.
- Wear proper hand and eye protection when searching for a high-pressure hydraulic leak. Do not use hands. Use a piece of wood or cardboard as a backstop to isolate and identify a leak.
- If injured by a concentrated high-pressure stream of hydraulic fluid, seek medical attention immediately. Serious infection or toxic reaction can develop from hydraulic fluid piercing the skin surface.



## 2.4. ELECTRIC MOTOR SAFETY

---

- Inspect the drive belts before using conveyor. Replace if frayed or damaged.
- Do not grab or touch drive belts during operation for any reason.
- Remember to ground electric motor before using conveyor.

## 2.5. TRANSPORT AND PLACEMENT SAFETY

---

- Transport conveyor in the full down position with slight tension on the cable.
- Properly place hitch pin and attach safety chain. Use a type of hitch pin that will not permit conveyor to separate from the towing vehicle.
- Always attach a SMV (slow moving vehicle) sign before transporting conveyor and equip (where required by law) the conveyor with the necessary lights for transportation. Always use hazard warning flashers on the tractor/towing vehicle when transporting, unless prohibited by law.
- Always travel at a safe speed, never exceeding 20 mph (32 km/hr). Reduce speed on rough surfaces and use extreme caution when turning corners or meeting traffic.
- Do not transport conveyor on a slope greater than 11°.
- Do not raise or lower conveyor until hazard area is clear, and do not permit anyone to stand on or beneath conveyor when raising or lowering.
- When lowering the conveyor the track shoe may become stuck; if this happens, do not continue to turn the winch handle counter-clockwise because it

will disengage the brake mechanism and create an unsafe condition. Too much slack in the cable may also cause the conveyor to drop suddenly.

- The winch must make a clicking sound when raising conveyor. If clicking sound stops, retain grip on handle, lower conveyor fully, and repair winch.
- After lowering conveyor, turn handle clockwise 2 clicks to lock winch brake.
- The winch is designed for manual operation only.
- Always keep a minimum of 3 cable wraps on the winch drum.
- Wheels must be free to move when raising or lowering conveyor. Do not use conveyor as a crane or hoist.

## 2.6. MAINTENANCE SAFETY

---

- Shut down and lock out all power before attempting maintenance of any kind.
- Support conveyor tube before attempting maintenance on the undercarriage. Conveyor should be in full down position for maintenance.
- After maintenance is complete, replace and secure all safety guards, safety devices, service doors, and cleanout covers.
- Use only genuine Westfield replacement parts or equivalent. Replacement parts such as intake guards, pulley guards, winches, and lift cables must meet ASAE standards or serious injury may result. Use of unauthorized parts will void warranty. If in doubt, contact Westfield or your Westfield dealer. Do not modify any conveyor components.

## 2.7. SAFETY DECAL LOCATIONS

---

- Keep safety decals clean and legible at all times.
- Replace safety decals that are missing or have become illegible. See decal location figures that follow.
- Replaced parts must display the same decal(s) as the original part.
- Safety decals are available from your distributor, dealer, or factory.

### 2.7.1. DECAL INSTALLATION

---

1. Decal area must be clean and dry, with a temperature above 50°F (10°C).
2. Decide on the exact position before you remove the backing paper.
3. Align the decal over the specified area and carefully press the small portion with the exposed sticky backing in place.
4. Slowly peel back the remaining paper and carefully smooth the remaining portion of the decal in place.
5. Small air pockets can be pierced with a pin and smoothed out using the sign backing paper.

## 2.7.2. DECAL LOCATIONS

Replicas of the safety decals that are attached to the equipment are shown in the figure(s) that follow. Proper safety procedures require that you familiarize yourself with the various safety decals and the areas or particular functions that the decals apply to as well as the safety precautions that must be taken to avoid serious, injury, death, or damage.

*\* Westfield reserves the right to update safety decals without notice. Safety decals may not be exactly as shown.*

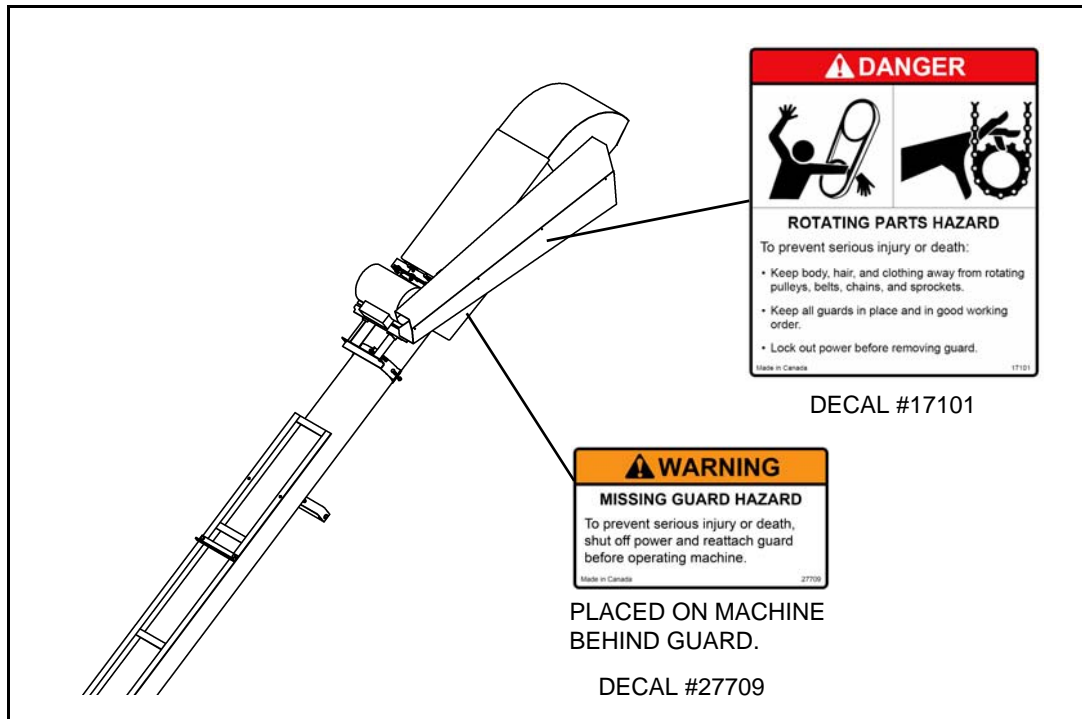

**Figure 2.2**

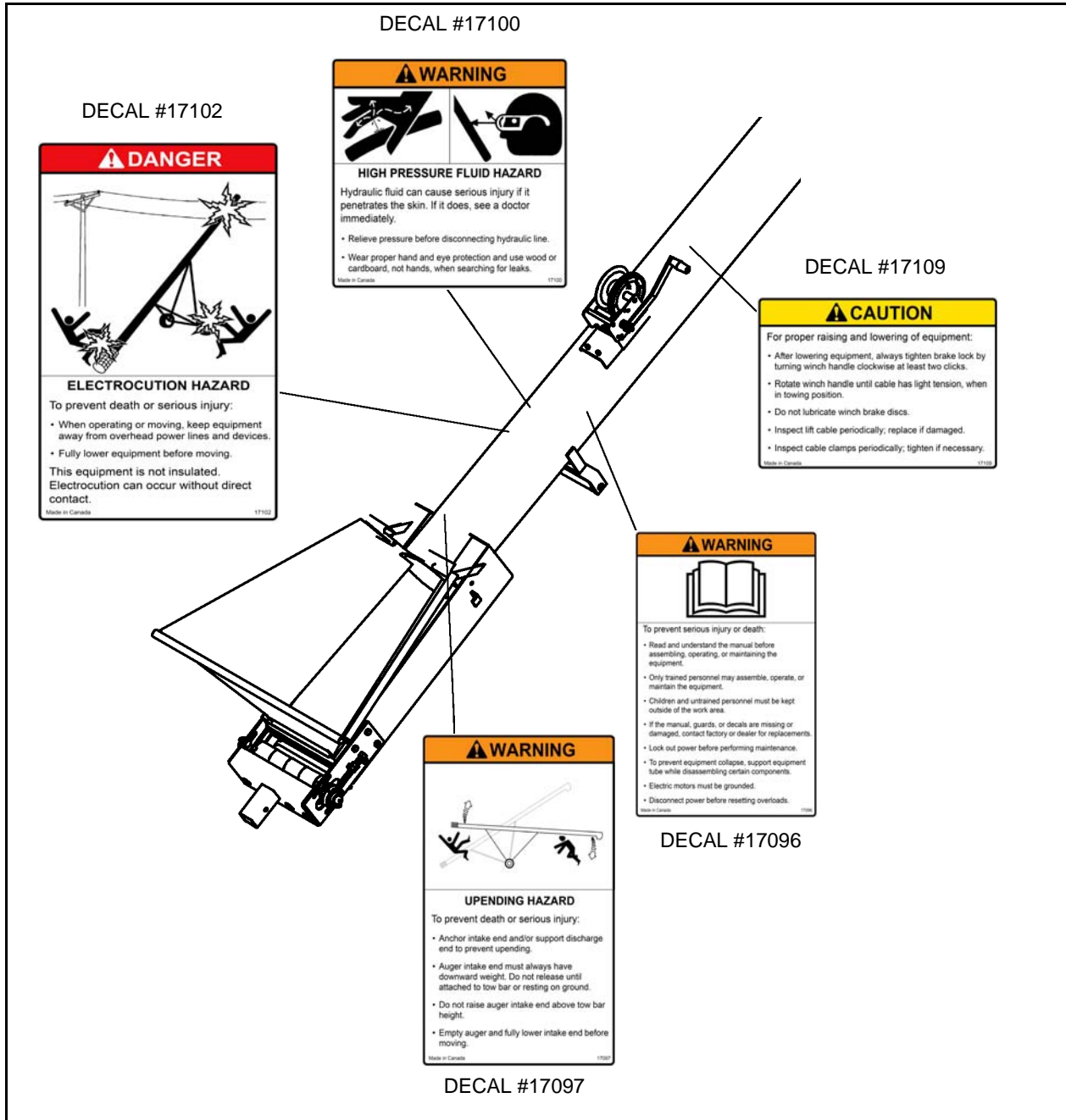

Figure 2.3

# 3. Assembly

**Warning:** Before continuing, please read the safety information relevant to this section in the safety section of this manual. Failure to follow the safety instructions can result in serious injury, death, or property damage.

Before assembling your new equipment, familiarize yourself with all the sub-assemblies and hardware that make it up. Arrange all parts for easy access. Carry out assembly in a large open area with a level surface.

**Important:** *Always have 2 or more people assembling the equipment. Because of the weight, do not attempt assembly alone.*

➔ Conveyors are available in various combinations. In most cases, the following instructions will apply to all. Where the assembly information varies, additional instructions are indicated by an arrow.

## 3.1. CONVEYOR TUBE

1. Lay out the tube sections on a series of benches or a large flat area. Position tubes so that the end containing the belt guide rollers are at opposite ends. (Figure 3.2).

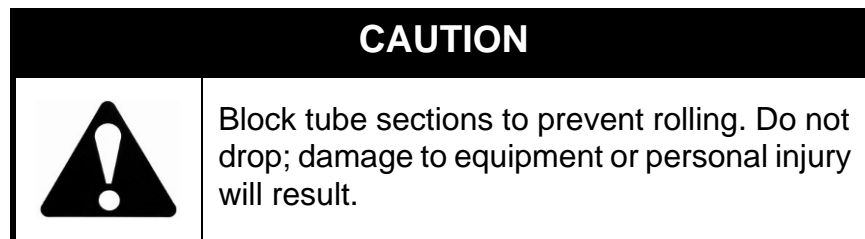

- Note:** 2. *Upper tube (with track) and lower tube (with winch) should be aligned as shown in Figure 3.2. Align tubes, butt flange ends together, and secure using eight 7/16" x 1" bolts.*
- Note:** *.For easier belt installation, use a 40' length of wire rope or cable.*
3. Feed 40' cable into discharge end of conveyor and snake it through to the intake end.
  4. Bolt belt roller guides onto tube section using two 7/16" x 1" bolts per roller guide (Figure 3.1).
  5. Loosen both end rollers. You are now ready to install belt.
  6. Attach the cable to the conveyor belting as seen in Figure 3.3. Make a loop in the cable and secure it with a cable clamp. Place bottom jaw of vise-grip through loop in cable, and clamp vise-grip tightly to conveyor belting.

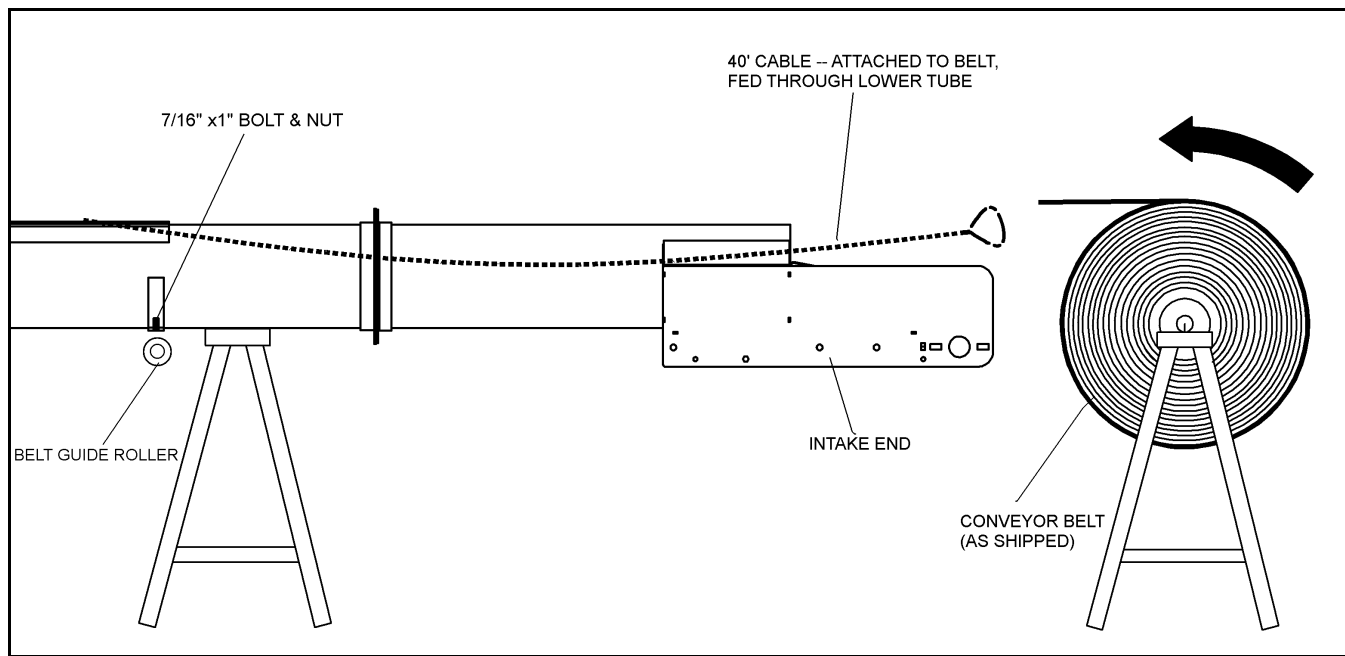

**Figure 3.1**

**Important:** *To avoid damage to belt edges when clamping vise-grip to belting, sandwich a strip of wood in between vise-grip and belt.*

7. Make sure belt grip side is facing up and smooth side is facing down.
8. Pull cable from discharge end of conveyor until belt emerges. Wrap belt over roller. Remove vise-grip and cable from belting.
9. Unwind remainder of the belt at the intake end and thread the free end through the belt support rollers. Start at the intake end and work toward the discharge end. The 2 ends should meet at the discharge end.
10. Pull the 2 separate ends of the belt together. Using a pair of vise-grips and a strap-puller (Figure 3.4), pull the belt together enough to inter-mesh with the belt lacing (metal tabs on the end of the belt). Install the connector wire through the lacing and crimp the retaining washer onto the end to hold it in place.

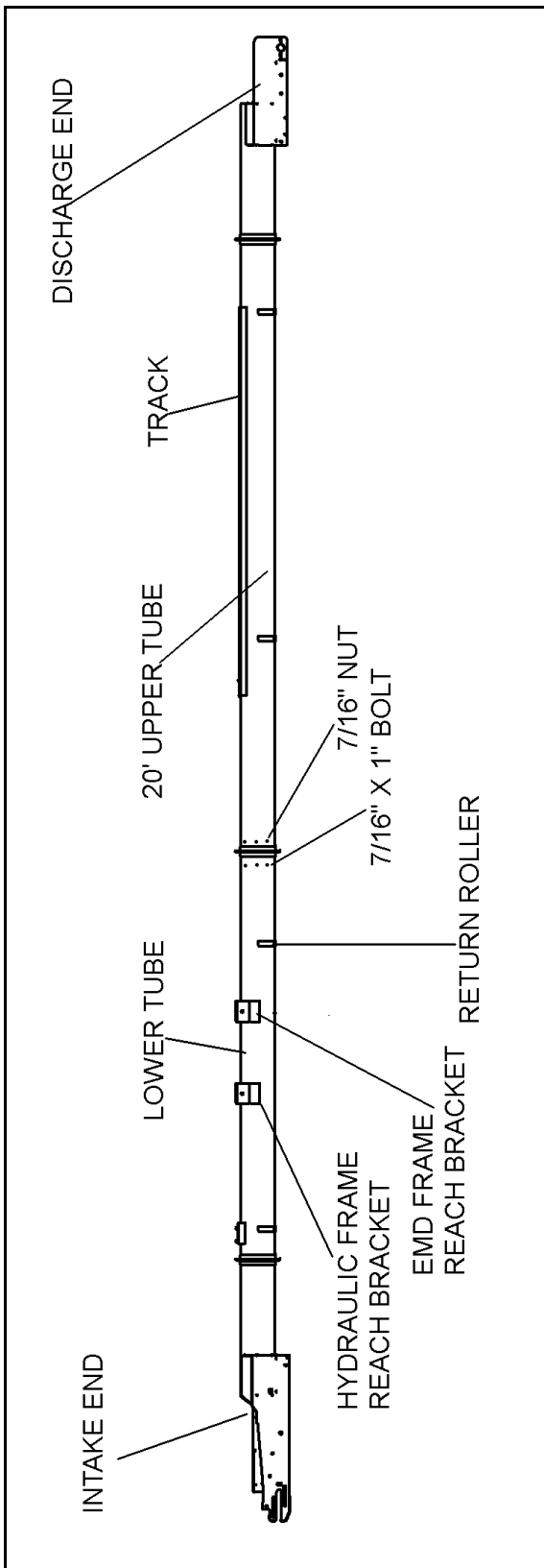

Figure 3.2

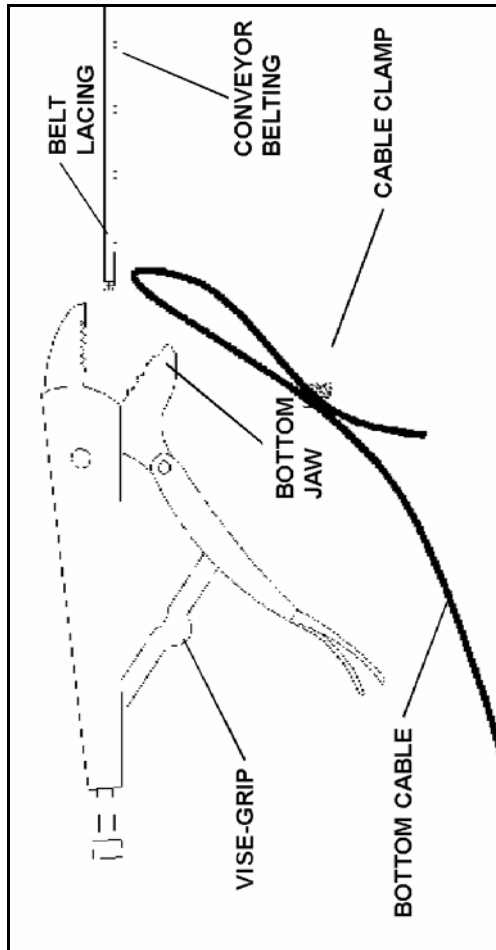

Figure 3.3

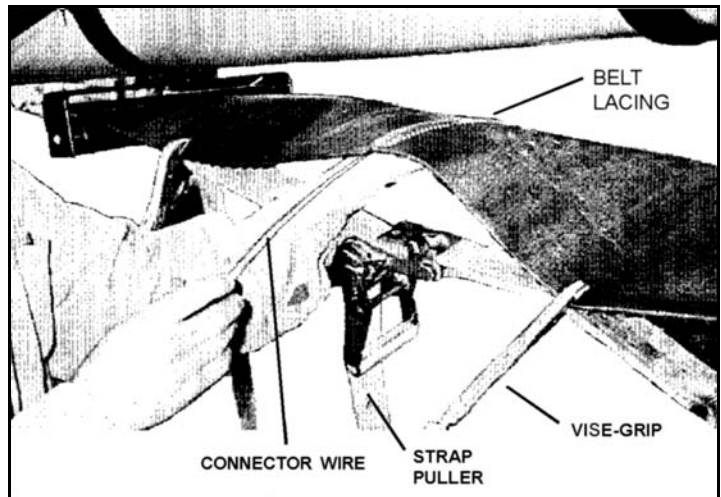

Figure 3.4

## 3.2. INTAKE HOPPER ASSEMBLY

**Note:** Refer to Figure 3.5 to Figure 3.8 and Table 3.1 for the assembly of the cloth hopper.

Attach hopper shield (18) to hopper (2) with 3 carriage bolts (7) and 3/4" nylock nuts, as in Table 3.1.

1. Apply grease to the upper cloth frame (4), and install the canvas hopper (22) over the frame as shown in Figure 3.5 and 3.6.



Figure 3.5



Figure 3.6

2. Lay cloth hopper assembly on the ground with the logo facing down.
3. Bolt the pivot shaft bracket (3) to the upper cloth frame (4) with 5/16" x 1" bolts (8) and 5/16" hex nuts (10). See Figure 3.8.

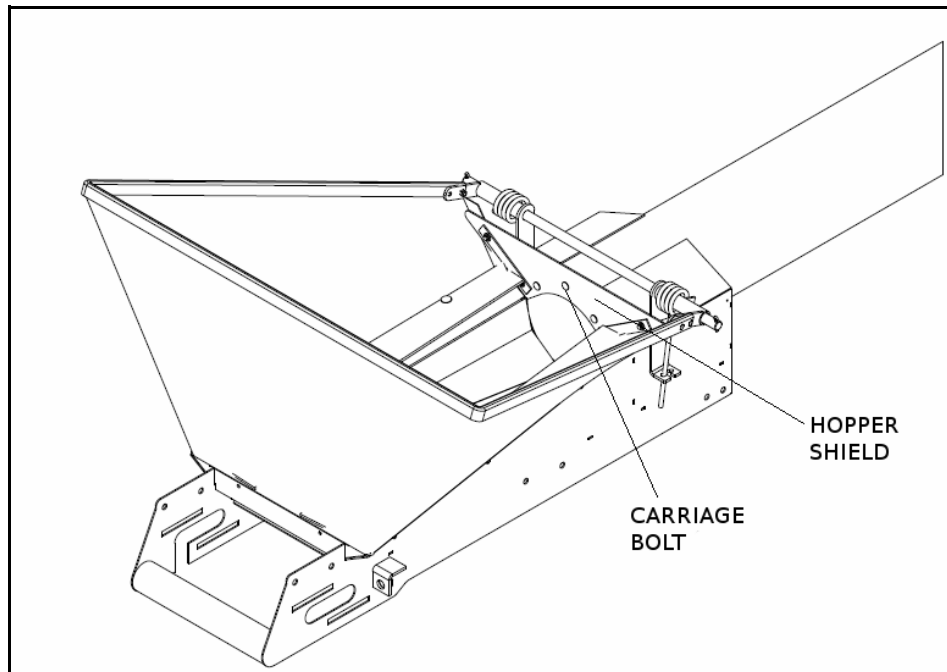

Figure 3.7

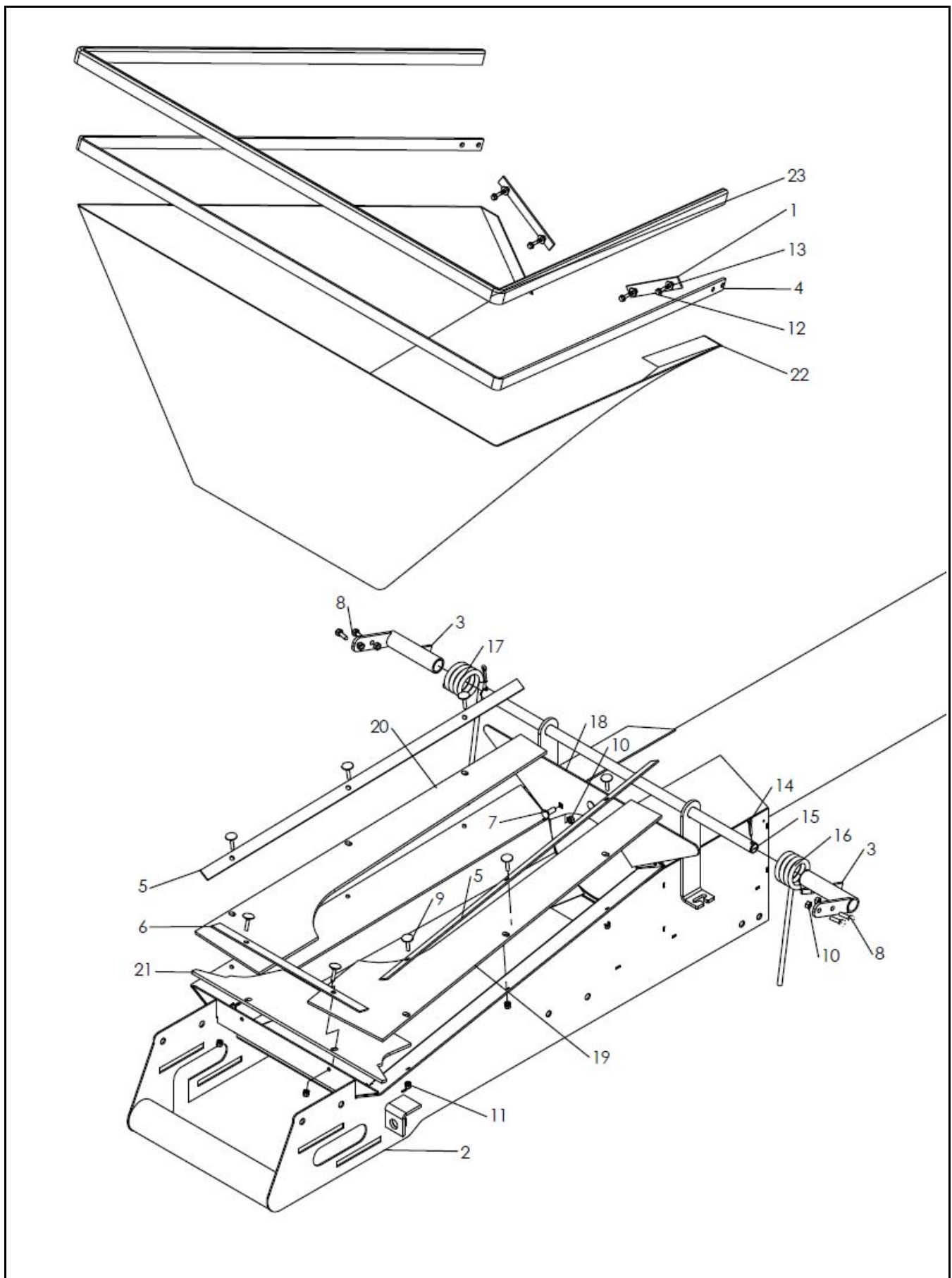

Figure 3.8

**Table 3.1**

ITEM	DESCRIPTION
1	Lower Cloth Frame STD Back
2	Hopper
3	Pivot Shaft Bracket
4	Upper Cloth Frame STD
5	Lower Cloth Frame STD Side
6	Lower Cloth Frame STD Front
7	Carriage Bolt 3/8" x 1" Fine
8	Bolt Hex 5/16" x 1"
9	Elevator Bolt 1/4" x 1-1/4"
10	Nut Hex 5/16"
11	Nut Nylock 1/4"
12	Self-Tapping Screw 1"
13	Flat Washer 1/4" USS Plated
14	Cotter Pin 3/16" x 1-1/2"
15	Hopper Pivot Shaft
16	Hopper Spring Left
17	Hopper Spring Right
18	Hopper Shield
19	Hopper Side Flashing Left
20	Hopper Side Flashing Right
21	Hopper Front Flashing
22	Hopper Canvas - 15 Conv.
23	Trimlock - 10' (3.05 m)
24	Nut Nylock 3/8"

4. Insert the hopper pivot shaft (15) through the mounting holes on the hopper, and slide the left (16) and right hopper spring (17) over the pivot shaft (15).
5. Slide the pivot bracket (3) over the ends of the hopper pivot shaft (15) as shown in Figure 3.9.
6. Clip springs (16,17) over tabs on hopper and on pivot shaft (3,15) as shown in Figure 3.9.
7. Secure hopper pivot shaft (15) with a 3/16" x 1-1/2" cotter pin (14). Spread cotter pin to position hopper assembly. Insert the lower cloth frame side (5) and lower cloth frame front (6) into the canvas.



**Figure 3.9**

8. Apply spray-on glue to the textured side of the side flashing (19,20) and front flashing (21). Also, glue can be applied to the top of the hopper lip to help hold components in place while assembling.
9. Install the front belt flashing (21). Make sure the flashing is flush with the top of the hopper, and that there is no gap between the belt and the flashing at the bottom.
10. Position the side belt flashing (19,20) in the same manner with the top of the flashing flush with the top of the hopper. Drill out holes through canvas and flashing using the hopper as a guide. Drill the front piece first, and then the sides.
11. Secure 1/4" x 1-1/4" elevator bolts (9) and 1/4" nylock nuts (11) to the front of the canvas hopper and then to the sides, as shown in Figure 3.10.



**Figure 3.10**

12. Insert lower cloth frame back (1) into the hopper canvas (22).
13. Insert self-tapping screws (12) and flat 1/4" washers (13) through the lower cloth frame back (1) to secure the back of the hopper, as shown in Figure 3.11.
14. Cut trim lock (23) to required length and use a rubber mallet to install.
15. Use a small propane torch or other heat source to warm and shape the flashing so that it conforms to the belt. Keep the heat source at a distance far enough from the flashing to prevent burning.



**Figure 3.11**

### 3.3. SPOUT HOOD INSTALLATION

1. Place hood slot around bearing assembly and install using four 1/4" x 1" self-tapping screws (3) and flat washers (4). See Figure 3.12.

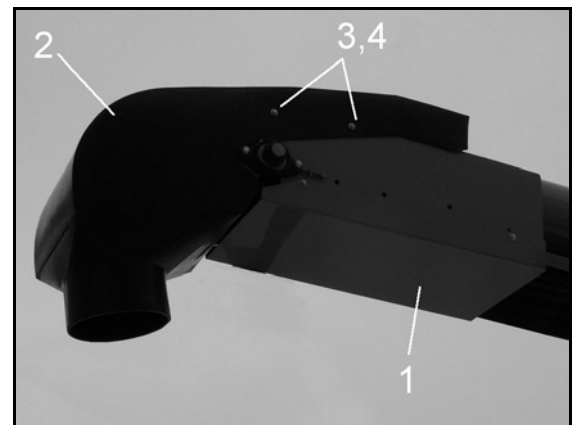

**Figure 3.12**

## 3.4. ELECTRIC MOTOR DRIVE (OPTION A)

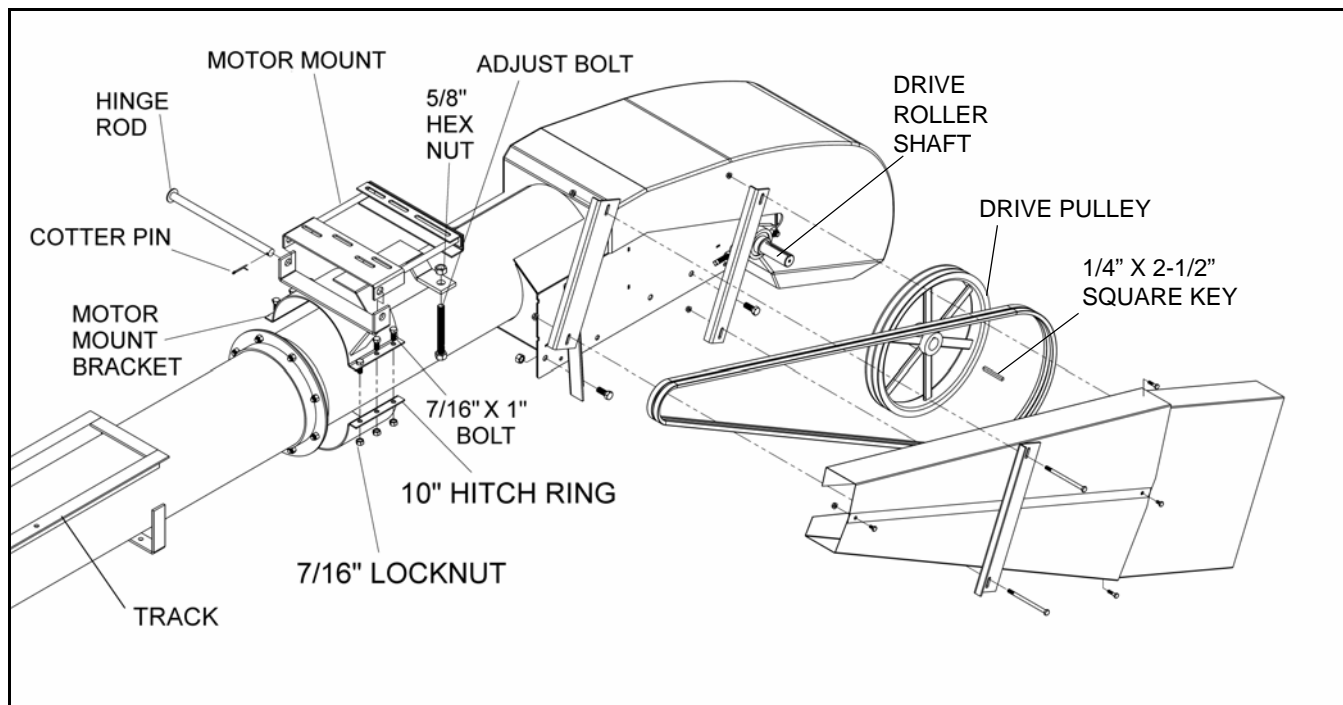

**Figure 3.13**

1. As shown in Figure 3.13, loosely secure motor mount bracket and 10" hitch ring onto conveyor tube using six 7/16" x 1" bolts and locknuts. Measure from the inside of the angle ring to the edge of the motor mount bracket. This measurement is 5".
2. Loosely connect motor mount to motor mount bracket using a hinge rod and cotter pin. Level with a 5/8" hexnut and adjust bolt.
3. Using a level, rotate the hitch rings until the motor mount and bracket are level with truck.
4. Tighten all bolts and locknuts.
5. Mount motor onto EMD mount. Do not tighten at this time.

### **When using an electric motor:**

- The motor and controls should be installed by a qualified electrician in accordance with all local and national codes.
- Incorporate a magnetic starter to protect the motor.
- The motor must have a manual reset button.
- Locate reset and starter controls so that the operator has full view of the entire operation.
- Locate main power disconnect switch within reach from ground level to permit ready access in case of an emergency.
- A main power disconnect switch capable of being locked (in the off position only) must be provided.

6. Snake power cord from motor toward intake end along tube (through track) and out to power source. Ensure that cord does not interfere with tracks movement or cord will get damaged.
7. Install motor and drive pulleys. (For pulley specifications, see Table 8.2 on page 50.) Use a level to make sure pulleys are in alignment. Insert 1/4" x 2-1/2" square key into large pulley and tighten set screws. Install belts.
8. Tension belt by tightening adjust bolt until belt is taut (about 1/8" deflection of belt at normal rest). Secure the position of the adjust bolt by tightening the 5/8" hex nut to the motor mount bracket.
9. Attach guard mounts to conveyor using two 1/2" x 1-1/4" bolts and locknuts. Do not tighten.
10. Attach upper guard mount to conveyor with 1/2" x 1-1/4" bolt and locknut (not shown). Do not tighten.
11. Assemble pulley guard and extension together, using two 1/4" x 1/2" bolts and whiznuts (Figure 3.14).
12. Install pulley guard over belt and pulley with equal spacing around belt.
13. Attach pulley guard to upper guard mount using two 1/4" x 1" bolts and whiznuts (Figure 3.14).
14. Both pulley guard and guard mount bracket should be able to pivot. Adjust pulley guard for equal spacing around belt.
15. Secure position of guard by securing the attach bracket to lower guard mount using two 5/16" x 5" bolts and whiznuts.
16. Tighten all bolts and nuts securely.

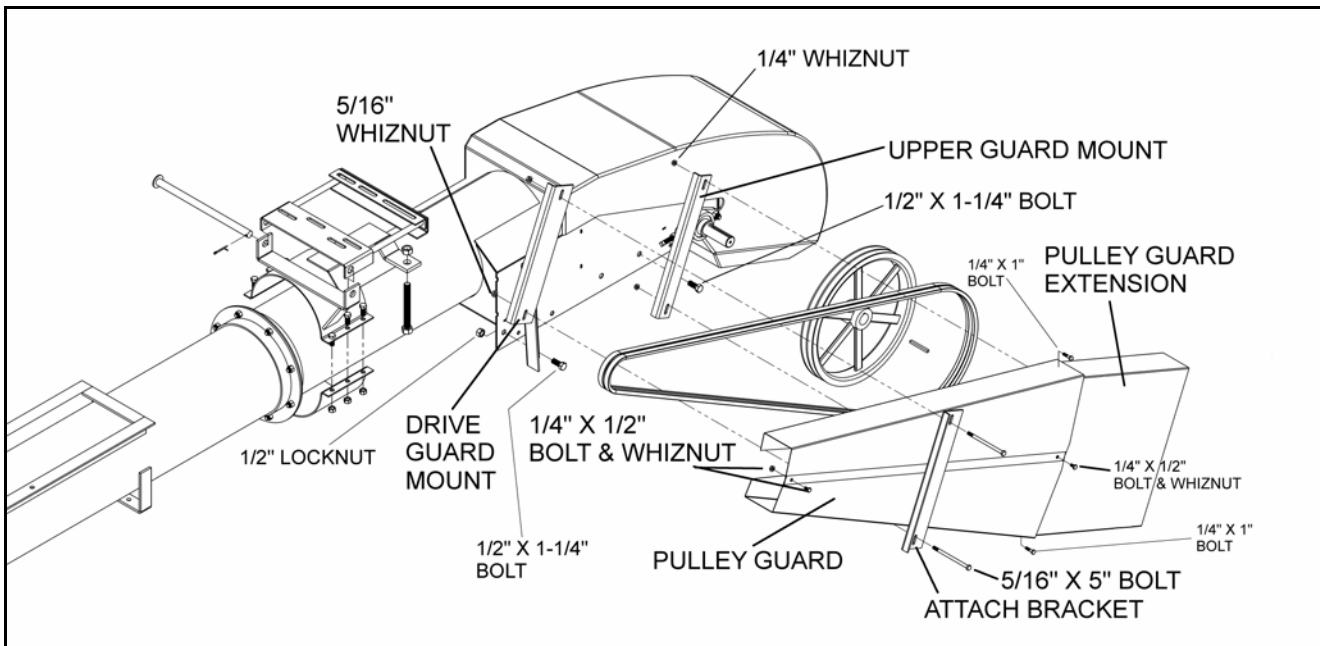

**Figure 3.14**

## 3.5. HYDRAULIC DRIVE (OPTION B)

1. Remove drive roller bearing bolts and replace with two 1/2" x 2-3/4" bolts (from kit).
2. Secure mount plate to bearing using 1/2" locknuts.(Figure 3.15)
3. Slide entire hydraulic motor assembly onto drive roller shaft (making sure chain coupler is seated properly) with a 1/4" x 1-1/2" square key.
4. Adjust the 2 pieces until holes on hydraulic motor assembly and bearing mount plate align properly. Secure both pieces by using four 3/8" x 1" bolts and locknuts. Tighten securely.

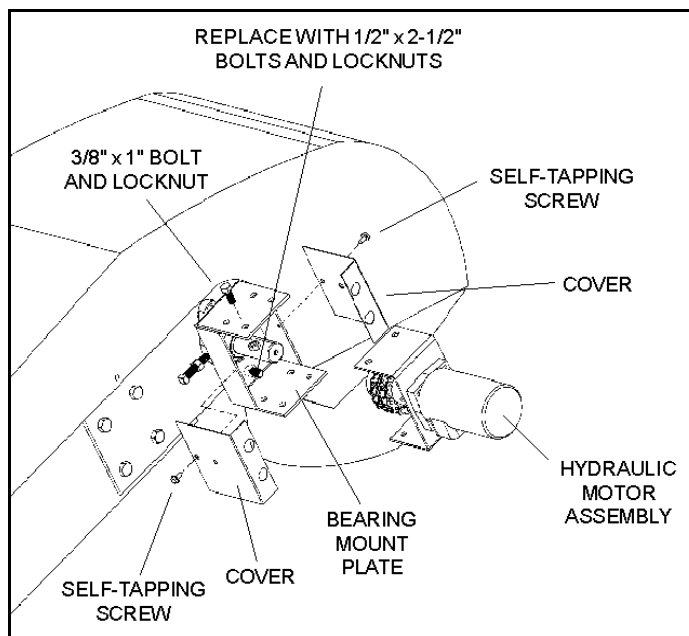

Figure 3.15

5. Install drive guards onto unit using self-tapping screws as shown in Figure 3.15.
6. Install hydraulic hoses to motor. (See "Other Specifications" on page 50.)
7. Snake hydraulic hose down through track toward intake end of conveyor and to tractor.

### NOTICE

Ensure hose does not interfere with operation of track shoe or hose damage will occur.

**Note:** *Hydraulic hose and couplers not included.*

## 3.6. TRACK SHOE AND CABLE

See Figure 3.19.

1. Assemble winch handle by sliding handle over flat sides of input shaft and fasten with 1/2" hex locknut as shown in Figure 3.16.

### CAUTION



Winch handle must be assembled as per instructions. Failure to do so will result in sudden winch failure causing damage to equipment and/or personal injury.

**Important:** *Do not remove or loosen the double locknut on input shaft—it is an important part of the brake system of the winch.*

2. Attach winch to winch mount with three 3/8" whiznuts (Figure 3.19).
3. Mount track shoe onto track by sliding shoe down from discharge end of conveyor.

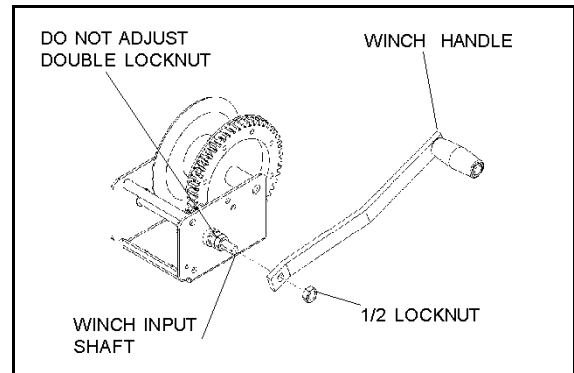
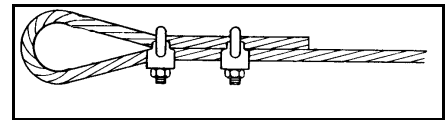

**Figure 3.16**

**Note:** *Track shoe must fit into track as shown in Figure 3.20. The double set of holes must point toward discharge end.*



4. **Electric motor drive:** bolt trackstop angle in first set of holes on track (when looking from discharge end)
5. **Hydraulic drive:** bolt trackstop angle into second set of holes. Using two 7/16" x 1" bolts and locknuts, tighten trackstop securely to track. See Figure 3.19 for clarification.
6. Loop 1/4" cable through track roller unit as shown (Figure 3.19) and anchor end to track (seen in Figure 3.18). Make sure that cable clamps are properly installed onto cable as shown in Figure 3.17.



**Figure 3.17**

**Important:** *Winch must have a minimum of 3 wraps of cable on drum when conveyor is in transport position.*

7. To connect cable to winch, use the method shown in Figure 3.19. Nuts must be on the outside of drum to prevent damage to cable.
8. Winch cable must run up from winch, around track shoe, then down to cable anchor at end of track. If cable is not properly installed, binding will occur and track shoe will not travel up and down track properly.

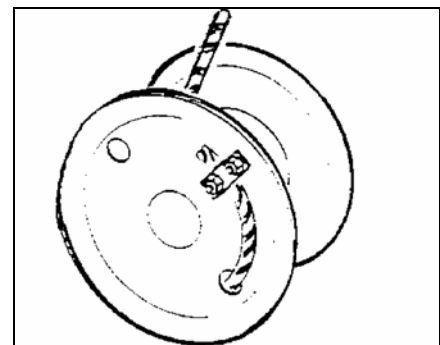
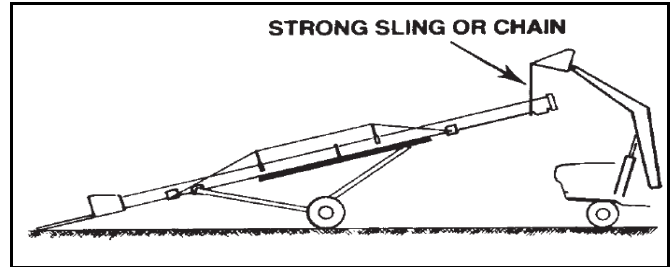

**Figure 3.18**

**Note:** *Looking from intake end, cable must loop from right to left through track shoe (shown in Figure 3.19).*



- g. Install tires and tubes on the wheels provided. Inflate to 18–24 psi (124–165 kPa). Wheels may be mounted on hubs at this time with four 1/2 x 1-1/4" wheel bolts.
5. Do not fully install tubing crossmember brace support at this time. Slide only the tube clamps (4) over the flat pressed ends of the lift arms.
6. Raise the discharge end of conveyor with a front end loader and a strong sling/chain or block and tackle. The height should be sufficient to clear undercarriage assembly.
7. Position transport undercarriage beneath conveyor assembly and attach lower reach arms to reach-arm bracket on bottom of conveyor with two 5/8" x 1-1/2" bolts and lock nuts. Do not over tighten. Tighten snug only; these bolts act as pivot points.



*For EMD (Electric Motor Drive) or hydraulic mounting positions and hole locations, see Figure 3.25.*

8. Attach lift arms to track shoe with 5/8" x 1-1/2" bolts and locknuts. Again, do not over-tighten; snug fit only.
9. Attach tubing crossbrace member to the lift arm. The correct assembly method is to slide tube clamp up lift arm and loosely attach the tubing crossbraces to the tube clamps with five 7/16" x 1" bolts and locknuts. Use a c-clamp vise grip to squeeze and hold the tube clamps in position for attachment to the tubing crossbraces. Once in position, tighten the bolts (Figure 3.24).



**Figure 3.20**

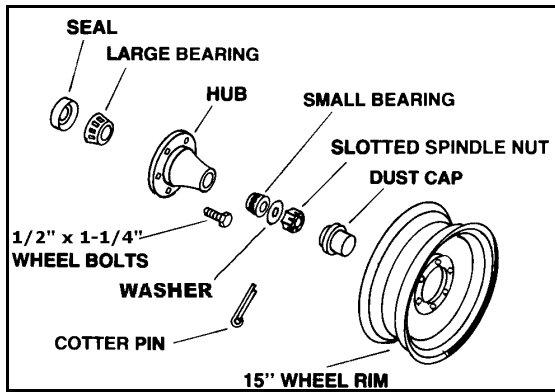

Figure 3.21

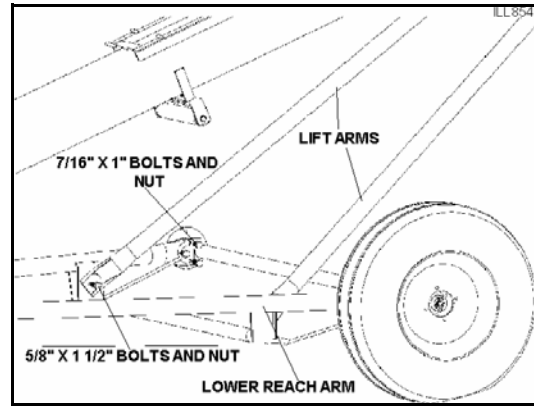



Figure 3.22

<b>WARNING</b>	
	<p>Do not remove tube support until conveyor is fully assembled.</p>

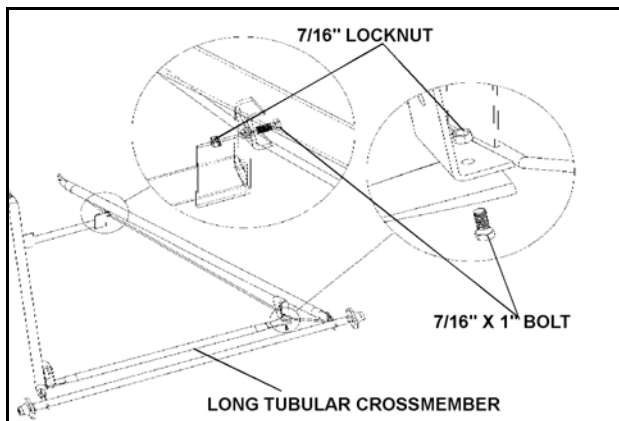

Figure 3.23

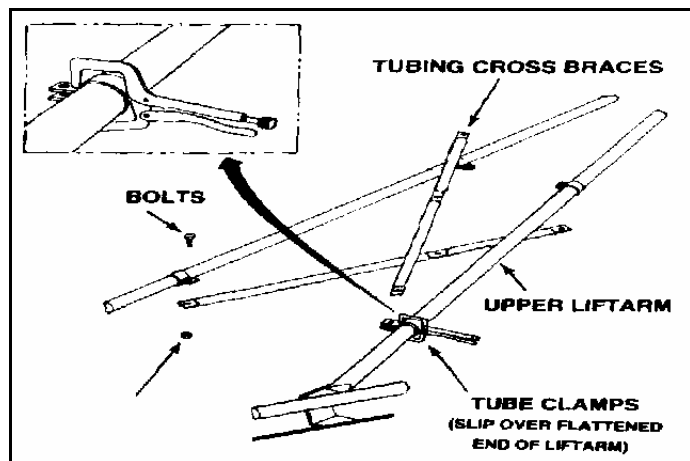

Figure 3.24

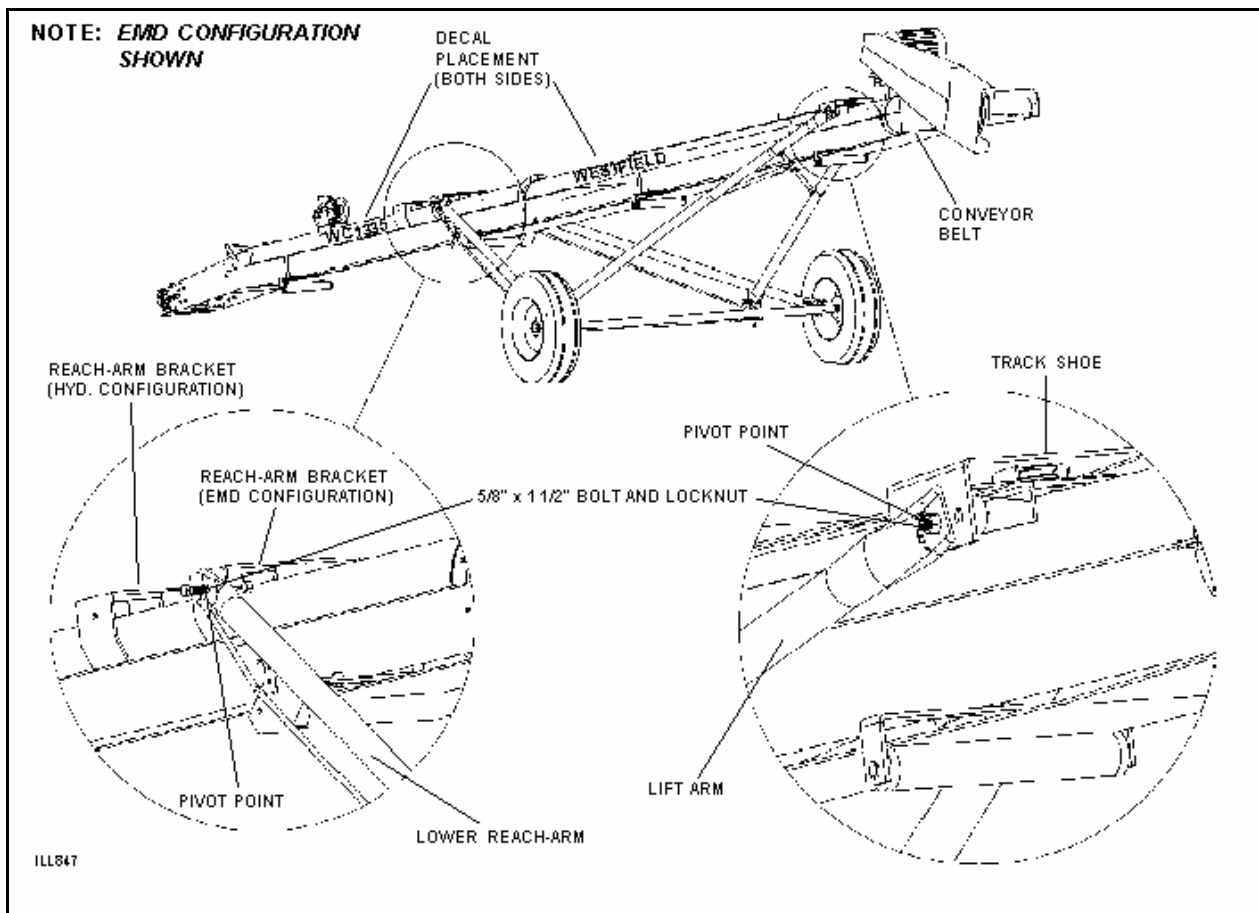

Figure 3.25

## 3.8. MODEL DECAL PLACEMENT

1. To place the model decal ("WC1335") on the conveyor, refer to Figure 3.25. This view is of the right side of the conveyor, determined when standing at the conveyor intake and looking towards the discharge. Ensure that each decal is centered on each side of the tube, at the approximate position shown.
2. Take care when removing the backing from the decal, as the numbers/letters may try to pull away from the tube surface.
3. Place the Westfield decals on upper tube below the discharge end. Center decals top and bottom on top tube, and place them so that they are clearly visible from the ground. See Figure 3.26 for an example.

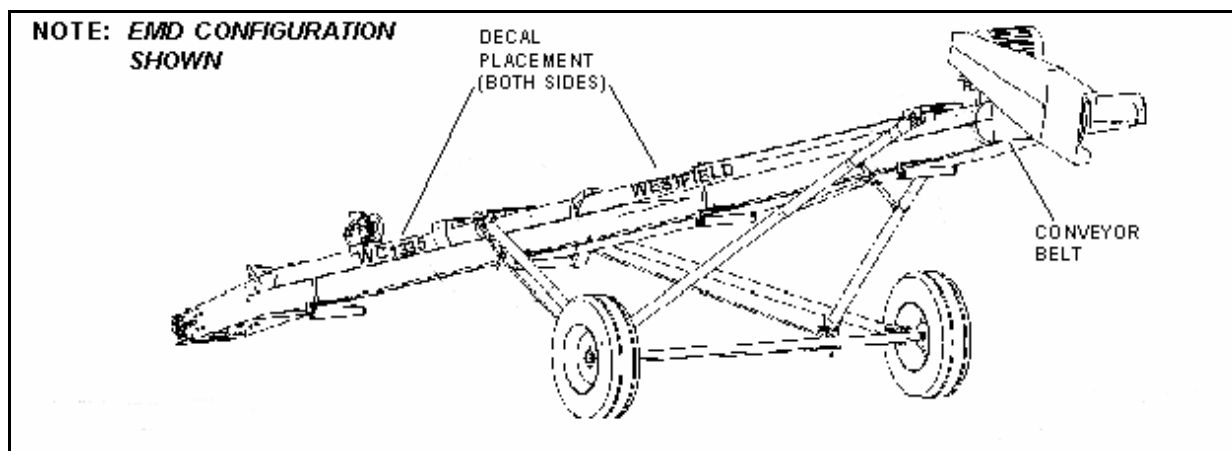

Figure 3.26

## 3.9. PLASTIC MANUAL HOLDER

Before beginning installation, ensure that all winch / conveyor lift controls are locked in place and shut down and/or lock out conveyor.

1. Attach holder to the lower frame arms. Manual holder must be accessible at all times, whether frame is up or down.
2. The manual holder cap must face up (towards the intake end). Attach manual holder with supplied zip ties. Tighten the zip ties, securing the holder in place.

**Note:** *Where possible, attach the zip ties around a frame brace tab to prevent the manual holder from slipping down the lower frame arms.*

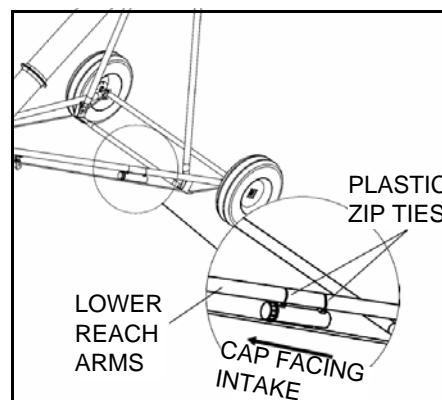

Figure 3.27

# 4. Transport & Placement

**Warning:** Before continuing, please read the safety information relevant to this section in the safety section of this manual. Failure to follow the safety instructions can result in serious injury, death, or property damage.

## 4.1. TRANSPORT

### 4.1.1. PRE-TRANSPORT CHECKLIST

Before transporting conveyor, ensure that:

1. Conveyor is in the fully lowered position.
2. Attach conveyor to towing vehicle with a pin and retainer. Always attach safety chain(s).
- ➔ 3. **Electric motor models:** unplug the power cord, wrap around frame, and secure to prevent dragging.
- ➔ 4. **Hydraulic powered models:** disconnect hydraulic hoses, remove power source, and wrap hose around frame to prevent dragging.

### 4.1.2. TRANSPORT PROCEDURE

1. Check with local authorities regarding conveyor transport on public roads. Obey all applicable laws and regulations.
2. Make sure the SMV (slow moving vehicle) emblem and all the lights and reflectors that are required by the local highway and transport authorities are in place, are clean, and can be seen clearly by all overtaking and oncoming traffic.
3. Use hazard warning flashers on tractor or towing vehicle when transporting unless prohibited by law.
4. Use caution when turning corners or meeting traffic. Always travel at a safe speed. It is not recommended that the machine be transported faster than 20 mph (32 km/h). Table 4.1 references the acceptable transport speed as per the ratio of tractor weight versus conveyor weight. The WC1335 weighs roughly 995lb.

**Table 4.1 Speed versus Weight Ratio**

Road Speed	Weight or fully equipped or loaded implement(s) relative to weight of towing machine
Up to 32 km/h (20 mph)	1 to 1, or less
Up to 16 km/h (10 mph)	2 to 1, or less
Do not tow if	More than 2 - 1

5. Use caution when moving conveyors over rolling terrain. In severe dips the intake end may contact the ground.

6. Never go across slopes of more than 11°. It is better to go straight up or straight down the slope.

<b>DANGER</b>	
	Stay away from overhead obstructions and power lines when operating and transporting. Electrocutation can occur without direct contact.

## 4.2. PLACEMENT PROCEDURE

---

### 4.2.1. UNDER HOPPER BOTTOM BINS

---

#### **BEFORE MOVING CONVEYOR UNDERNEATH HOPPER BIN:**

1. Confirm that hopper is centered between the hopper bin vertical legs. This ensures that the operator has adequate clearance.
2. Collapse the cloth hopper until it is positioned under the bin.
3. Move conveyor into place, raise the conveyor spout to desired height.
4. Ensure winch is locked.
5. Make sure that foreign material is not jammed against the belt under the hopper.

### 4.2.2. FILLING BINS

---

1. Back the machine up to the storage facility while it is in its lowered configuration. Set the park brake on the tractor before dismounting.

<b>WARNING</b>	
	Set the park brake on the tractor before dismounting.

2. Use the winch to raise the machine so it clears the storage facility.
3. Slowly back the machine up until the outlet is over the opening in the storage facility.
4. Use the winch to slowly lower the machine to the bin.

<b>NOTICE</b>	
Do not rest the spout or outlet hood on the bin. This may cause hood or belt damage.	

5. Place chocks in the front and back of each wheel.
6. When releasing conveyor from the towing vehicle, test the intake end for downward weight.
7. Unhook the unit from the tractor or towing vehicle and lower hopper to the ground.

<b>DANGER</b>	
	Upending hazard: Do not hook or unhook hitch unless weight is down.

8. Lower the machine to the bin, but do not let it rest on the bin.
9. Remove the hitch from the machine to prevent interfering with other equipment.



# 5. Operation

**Warning:** Before continuing, please read the safety information relevant to this section in the safety section of this manual. Failure to follow the safety instructions can result in serious injury, death, or property damage.

## 5.1. PRE-OPERATION CHECKLIST

---

### **BEFORE OPERATING THE CONVEYOR EACH TIME:**

- Review Section 2.2. on pg. 9 and follow all set-up instructions.
- Check angle of machine and ensure that it is not at too steep an angle to move grain. See Section 8.1. on pg. 49 for more help.
- Service the machine per the schedule outlined in Section 6.1.
- Use only a tractor or electric motor of adequate power to operate the machine. (See “Other Specifications” on page 50.)

**Important:** *Check winch and cable. There should be at least three complete wraps of cable around the winch drum in transport position. Check that cable anchor on winch drum is tight. Inspect cable and replace if frayed or damaged.*

- Check that cable clamps are secure.
- Check that drive and conveying belts are not frayed or damaged and that they are properly adjusted and aligned. See Section 6.3.4.
- Be sure wheels are chocked.
- Check that hopper and spout areas are free of obstructions.
- Support discharge end or anchor intake end before using.

## 5.2. MACHINE BREAK-IN AND OPERATION

---

Although there are no operational restrictions on the conveyor when used for the first time, it is recommended that the following items be checked:

### **BEFORE STARTING:**

1. Read the conveyor and tractor (if necessary) operation manuals.
2. During the first few minutes of operation, check the conveyor belt alignment to ensure preset alignment does not vary under loaded conditions. See Section 6.3.4.

### **AFTER OPERATING OR TRANSPORTING FOR 1/2 HOUR:**

1. Re-torque all the wheel bolts.
2. Re-torque fasteners and hardware.
3. Check the drive and conveyor belt tension and alignment. Tension or align as required. See Sections 6.3.3. and 6.3.4.

### **AFTER OPERATING FOR 5 AND 10 HOURS:**

1. Re-torque all wheel bolts, fasteners, and hardware.

2. Check the drive and conveyor belt tension and alignment. Tension or align as required.

### 5.2.1. DRIVE SETUP

---

**Note:** Check belt speed (go to Section 5.2.7. on pg. 38).

➔ **HYDRAULIC DRIVE MODEL:**

1. Back tractor into position.
2. Chock tractor wheels.
3. Plug hydraulic hoses into tractor couplers. Check flow direction to ensure belt is moving forward.

➔ **ELECTRIC MOTOR MODEL:**

1. Have a certified electrician provide power to the machine.
2. Provide convenient shutdown switches and comply with local electrical codes.
3. Use a totally enclosed electric motor when conveying in extremely dusty conditions. Be sure electric motor is properly grounded.

### 5.2.2. STARTING CONVEYOR

---

WARNING	
	Anchoring and/or support of the conveyor during operation is necessary. When emptying the conveyor, the weight balance transfers to the upper end of the machine, which can cause upending.

➔ **HYDRAULIC DRIVE INSTRUCTIONS**

1. Place all controls in neutral.
2. Start tractor and run at low idle.
3. Engage hydraulic control lever and increase engine speed to desired speed. See "Appendix" on page 49.

**Note:** *The correct operation of hydraulic systems is directly linked to the pump's ability to supply the correct oil flow and pressure. If you cannot obtain the correct belt speed, check with the dealer to ensure the power unit is delivering the correct oil volume and pressure.*

CAUTION	
	Conveyor should not be left in a raised position for extended periods of time. Fully lower conveyor to prevent the risk of damage or personal injury.

## ➡ **ELECTRIC DRIVE**

1. Turn the electric motor ON.

### **5.2.3. CONVEYOR SHUTDOWN**

---

#### ➡ **HYDRAULIC DRIVE MODELS:**

1. Run until the belting is empty.
2. Reduce engine speed to low idle.
3. Place hydraulic control lever in neutral.
4. Shut off engine and remove ignition key.

#### ➡ **ELECTRIC MOTOR MODELS:**

1. Run until the belting is empty.
2. Turn off motor and lock out power source.

### **5.2.4. EMERGENCY SHUTDOWN**

---

Although it is recommended that the tube be emptied before stopping, in an emergency situation, stop or shut down the power source immediately.

**Important:** *Lock out all power and ensure the machine components come to a stop before inspecting.*

Correct the emergency and inspect the conveyor to ensure the components are free and clear before resuming work.

### **5.2.5. RE-STARTING (FULL TUBE)**

---

When the machine is shut down inadvertently or for an emergency, the tube will still be filled with material.

➡ **Electric Drives:** It may be necessary to tighten the drive belts slightly to handle the heavier than normal loads. See “Drive Belt Tension & Alignment (Electric Drive)” on page 45.

### **5.2.6. CONVEYOR OPERATING ANGLES**

---

Typically, the conveyor lift can set the tube angle at any position between 12° and 30° when operating. Because the belt does not have roll back barriers, the material will roll back if the angle is too steep. Do not position the conveyor at an angle steeper than the angle of repose of the material to be moved.

See Section 8.1. for help on determining these angles.

**Note:** *The lower the angle, the greater the capacity.*

## 5.2.7. BELT SPEED

---

The best results are obtained when the input drives are set to provide a belt speed of 600 to 650 ft/min.

Count the number of belt revolutions per minute to determine belt speed. Approximate belt length is 72' (1.83 m).

*Use the connector splice as a reference when counting belt revolutions.*

Contact your dealer or the factory for the appropriate drive components to give the recommended belt speed.

## 5.2.8. OPERATING TIPS

---

- Direct the flow of material into the input hopper in the direction of the belt for the best capacity.
- Attempting to move material at too steep an angle can result in excessive slide back and poor capacity.
- Always listen for any unusual sounds or noises (metal-against-metal contact, such as belt clips hitting the tube opening at the intake). If you hear any, stop the machine, determine the source and correct the problem before resuming work.
- Do not run the machine for long periods of time without material on the belting (this increases belt wear).
- Do not allow spout to rest directly on the storage facility. Tie down the intake (hopper) or weigh it down to prevent upending.
- To achieve maximum capacity, feed material onto belt until material tube clearance is 1/2" (1.27 cm); do not flood feed hopper.

**Note:** *The best capacity is obtained when the material is loaded into the hopper as close to the tube as possible.*

# 6. Maintenance & Storage

**Warning:** Before continuing, please read the safety information relevant to this section in the safety section of this manual. Failure to follow the safety instructions can result in serious injury, death, or property damage.

## 6.1. MAINTENANCE SCHEDULE

---

### 6.1.1. INITIAL START-UP SERVICING

---

Since the belt alignment is preset to run true under a condition of no load, it is important to check alignment and make adjustments if required during the initial few minutes of loaded operation. To adjust alignment, see Section 6.3.4. Conveyor Belt Alignment on page 42.

### 6.1.2. 8 HOURS OR DAILY

---

- Check the conveyor belt tension and alignment. See Sections 6.3.3. and 6.3.4.
- ➡ **Electric Drive:** Check drive belt tension and alignment.
- ➡ **Hydraulic Drive:** Check hoses for wear.

### 6.1.3. 40 HOURS OR WEEKLY

---

- Check the conveying belt tension and alignment (See Section 6.3.3.).
  - Check condition of hopper flashing. Be sure it seals the hopper and prevents grain leakage.
- ➡ **Hydraulic Drive:** Look for hydraulic leaks and repair if required.

### 6.1.4. 200 HOURS OR ANNUALLY

---

- Check tire pressure and add air if required. Inflation pressure details can be found on the tire itself.
- Check roller bearings for wear. Any rollers making noise, getting hot while running, or that give should be replaced.
- Repack wheel bearings.
- Wash machine.
- Inspect roller lagging to see if it is showing signs of wear.
- Check belt lacing. If any clips are worn through, replace all lacing.
- Lubricate chain coupling on hydraulic drive.

- Check hopper flashing for wear and replace any that are worn. Worn flashing will cause hopper leakage.

**NOTICE**

Operating the conveyor with a damaged roller will result in a damaged conveyor belt.

## 6.2. MAINTENANCE CHECKLIST

See Lubrication and Maintenance sections for details of service. Photocopy this page to continue record keeping.

✓ Check    CL Clean    L Lubricate    C Change    R Re pack

8 Hours/Daily	Day	1	2	3	4	5	6	7	8	9	10	11	12	13	14	15	16	17	18	19	20	21	22
✓ Conveyor Belt Tracking																							
✓ Fuel & Oil Level(s)																							
	Day	23	24	25	26	27	28	29	30	31	32	33	34	35	36	37	38	39	40	41	42	43	44
✓ Conveyor Belt Tracking																							
✓ Fuel & Oil Level(s)																							
	Day	45	46	47	48	49	50	51	52	53	54	55	56	57	58	59	60	61	62	63	64	65	66
✓ Conveyor Belt Tracking																							
✓ Fuel & Oil Level(s)																							
	Day	67	68	69	70	71	72	73	74	75	76	77	78	79	80	81	82	83	84	85	86	87	88
✓ Conveyor Belt Tracking--																							
✓ Fuel & Oil Level(s)																							
40 Hours/Weekly	Week	1	2	3	4	5	6	7	8	9	10	11	12	13	14	15	16	17	18	19	20	21	22
✓ Belt Tension & Alignment																							
✓ Conveyor Belt Tracking																							
✓ Hopper Flashing Condition																							
✓ Check for Hydraulic Leaks																							
Electric Drive Models																							
✓ Drive Belt Tens. & Align.																							
200 hours / Annually	Year 1	Year 2	Year 3													Year 1	Year 2	Year 3					
✓ Tube Straightness																							
✓ Roller Bearings																							
R Wheel Bearings																<b>Hydraulic Drive Models</b>							
CL Machine																L Roller Chain-Input Coupler							
✓ Roller Lagging																							
✓ Check Tire Pressure																							

## 6.3. SERVICE & MAINTENANCE PROCEDURES

---

By following a careful service and maintenance program for your machine, you will enjoy many years of trouble-free service.

### 6.3.1. FLUIDS AND LUBRICANTS

---

#### GREASE:

- Use SAE multi-purpose high temperature grease with extreme pressure (EP) performance. SAE multi-purpose lithium based grease is also acceptable.

#### STORING LUBRICANTS:

- Your machine can operated at top efficiency only if clean lubricants are used. Use clean containers to handle all lubricants. Store them in an area protected from dust, moisture, and other contaminants.

### 6.3.2. GREASING

---

**Note:** *Most original equipment bearings used by Westfield are sealed units and will not accept grease.*

1. Wipe grease fitting with a clean cloth before greasing to avoid injecting dirt and grit.
2. Replace and repair broken fittings immediately.
3. If fittings will not take grease, remove and clean thoroughly. Also clean lubricant passageway. Replace fitting if necessary.

Use the maintenance checklist provided to keep a record of all scheduled maintenance (See Section 6.2.).

### 6.3.3. CONVEYOR BELT TENSION

---

Adjusting your conveyor belt for proper tension helps to ensure trouble-free operation and long belt life. A conveyor belt only needs to be tight enough to not slip on the drive roller. If the belt is too loose, it will slip on the drive roller making a noticeable sound and slowing the belt down. To correct belt slippage and set proper tension in the belt, follow the steps in the corresponding section below. Only the steps that apply are numbered.

**Important:** *If belt is slipping and adjustment bolts are fully tightened, then belt must be shortened and relaced. See Section 6.3.6.*

*Belt should not be easy to pull from the hopper transition sides, if it is easy you need to tension the belt.*

WARNING	
	Ensure ignition key is removed, or lock out power source before adjusting or servicing conveyor.

NOTICE	
Do not operate conveyor if belt is slipping. Stop conveyor and tighten belt. Failure to do so will damage the belt and may void the warranty.	

**Important:** *Some belts may have uneven edges, appearing misaligned. Wait until the belt makes a complete revolution before adjusting rollers.*

### BELT TENSION INSTRUCTIONS TOP DRIVE

WARNING	
	Before tensioning belt, remove ignition key and lock out power.  After tensioning belt, replace guards if removed.

1. Loosen bearing bolts and jam nut at tightener roller (see Figure 6.1).
2. Tighten tightener bolts equally, use tape to verify (see Figure 6.1). Belt should deflect 1-2" (2.54 cm - 5.08 cm) when pushed down with a 5 lb (22.2 newton) force, or be difficult to pull from sides of hopper transition.
3. Tighten bearing bolts and jam nut.
4. Check belt tension by running conveyor for one minute. If belt is not slipping, then proceed to next step; otherwise repeat from step 1.
5. If belt is not slipping, but now running to one side, the tensioned roller needs to be re-aligned. See "Conveyor Belt Alignment" on page 42.

### 6.3.4. CONVEYOR BELT ALIGNMENT

---

If your belt is tracking to one side, use the instructions below and follow the steps listed to center it. Follow the steps in the appropriate section(s) in order. If you are unsure where the problem is, start at the beginning of this section and work your way to the end. Skip sections that do not apply. The process can be lengthy but will help ensure trouble-free operation and long belt life.

**Important:** *Ensure that conveyor is empty of all product before adjusting belt alignment.*

<b>WARNING</b>	
	Before aligning belt, remove ignition key and lock out power.  After aligning belt, replace guards if removed.

### HOPPER ROLLER

1. Loosen bearing bolts and jam nut.
2. Rotate adjustment bolt 1/2 turn on the side the belt is running toward.
3. Restart conveyor and run empty for one minute.
4. Stop conveyor, remove ignition key or lock out power source.
5. If belt has centered, then move to next step below; otherwise, repeat from step 2.
6. Tighten bearing bolts and jam nut.

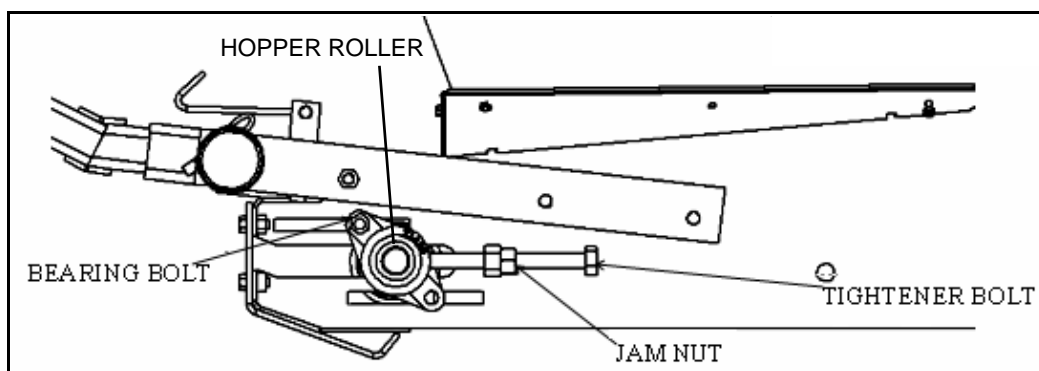

**Figure 6.1 1335 Hopper Roller**

### SPOUT ROLLERS

1. Loosen bearing bolts and jam nut.
7. Rotate adjustment bolt 1/2 turn on the side the belt is running toward.
8. Restart conveyor and run empty for one minute.
9. Stop conveyor, remove ignition key or lock out power source.
10. If belt has centered, then move to next step below; otherwise, repeat from step 2.
11. Tighten bearing bolts and jam nut.
12. Tighten drive roller mount plate bolts.

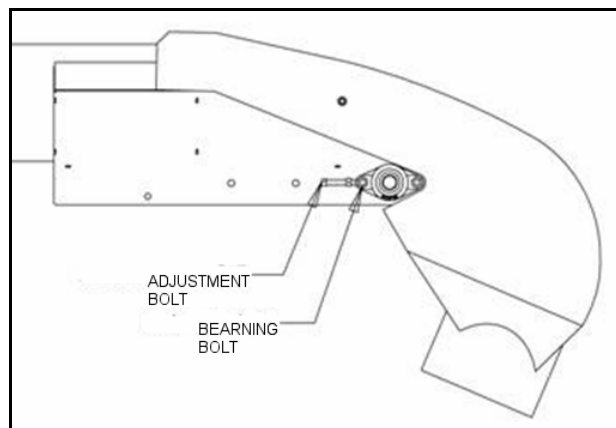

**Figure 6.2 Spout**

## RETURN ROLLERS

1. Start at hopper or last adjusted roller and check that belt is centered on each belt return bracket.
2. If belt is not centered, adjust bracket toward hopper slightly on side belt is tracking toward.
3. Restart conveyor and run empty for one minute.
4. Stop conveyor, remove ignition key or lock out power source.
5. If belt has not centered repeat from step 2.

## 6.3.5. CONVEYOR BELT REPLACEMENT

---

1. Rotate the belting until the lacing is by the hopper or easily accessible.
2. Move the tension roller to its loosest position.
3. Pull all the slack to the lacing area.
4. Remove the lacing pin (see Figure 6.3).
5. Attach one end of the replacement belt to the belt end being removed, closest to the hopper.
6. Pull the old belt out and the new belt will be threaded into place.
7. Disconnect the old belt.
8. Reattach conveyor belt ends together. If required, use a ratchet strap clamped to both ends of belt to cinch belting ends together.
9. Install lacing pin and crimp retainer clips onto each end of the lacing pin.
10. Remove ratchet strap and tighten conveyor belt. See Section 6.3.3.
11. Check and set belting alignment. see Section 6.3.4.
12. Engage conveyor drive. Allow to run for 30 seconds, then shut down conveyor and inspect lacing.

## 6.3.6. BELT RELACING

---

1. Rotate the belting until the lacing is by the hopper or easily accessible.
2. Loosen conveyor belt and remove lacing retainer clip and pin.
3. Using a square and sharp knife, cut lacing off right behind the lacing clips. Cut belt **MUST** have a square end.
4. Use knife to cut Chevron pattern off 1" (2.54 cm) back from end of belt. This ensures that the lacing is centered and fully seated on the belt.
5. Use lacing tool to install new lacing clips. Lacing clips are one clip shorter than belt width. For example: the lacing for a 15" (38.1 cm) wide belt is 14 clips. Center lacing on belt and install lacing as per instructions on lacing tool.
6. Reattach conveyor belt ends together. If required, use a ratchet strap clamped to both ends of belt to cinch belting ends together.
7. Install lacing pin and crimp retainer clips onto each end of the lacing pin.
8. Remove ratchet strap and tighten conveyor belt. (See Section 6.3.3.)
9. Check and set belting alignment. (See Section 6.3.4.)

10. Clear area of all bystanders and engage conveyor drive. Allow to run for 30 seconds, then shut down conveyor and inspect lacing.

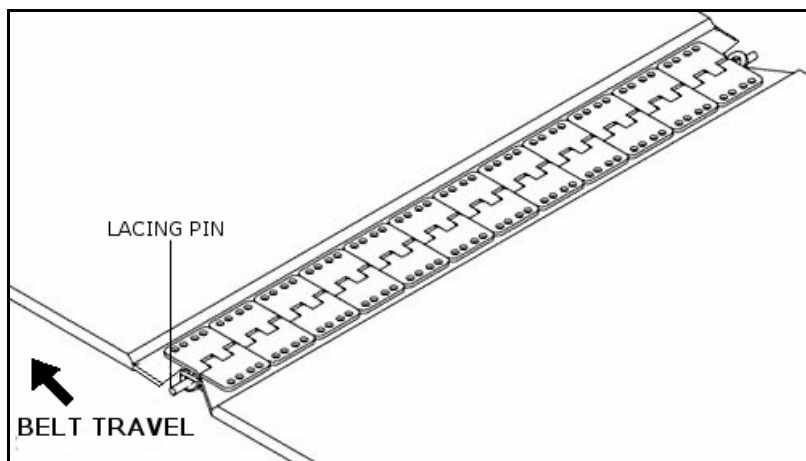



Figure 6.3 Belt Lacing Pin

### 6.3.7. DRIVE BELT TENSION & ALIGNMENT (ELECTRIC DRIVE)

Power to the conveyor is transmitted through a set of v-belts. The drive system must be maintained at the proper belt tension and pulley alignment to obtain desired performance and life. When maintaining the belt drive system follow the appropriate sections below.

<b>WARNING</b>	
	Before working on drive belt: Electric Drives: Turn motor off and unplug power cord or turn off power at master panel.

#### **BELT TENSION**

1. Push on the center of the belt span with a force of approximately 5 lb (22.2 newton).
2. The belts will deflect approximately 1/4" (.64 cm) to 1/2" (1.27 cm) when properly tensioned.
3. Move the motor base to set drive belt tension.
4. Close and secure guards.

#### **BELT ALIGNMENT**

1. Lay a straight edge across the pulley faces to check the alignment.
2. Use the pulley hub to move the pulley to the required position for alignment.
3. Tighten hub bolts to secure pulley on shaft.
4. Check belt tension.
5. Close and secure guards.

## BELT REPLACEMENT

1. Move motor base to its loosest position.
2. Remove old belts and replace with new ones.
3. Check pulley alignment. Adjust if required.
4. Close and secure guards.

## 6.4. STORAGE PROCEDURE

---

### TO PROTECT CONVEYOR IN STORAGE DURING THE OFF-SEASON:

1. Lower the conveyor to full down position until track shoe rests against transport bracket.
2. Rotate belt so that belt lacing is left inside the tube. This prevents weathering and increases lacing life.
3. Remove all residual material from the hopper and tubes.
4. Lubricate all grease fittings per maintenance procedure.
5. Inspect conveyor for damage and note any repairs required. Order replacement parts from your dealer.
6. Touch up all paint nicks and scratches to prevent rusting.
7. Check tire pressure and inflate to side wall recommendations.
8. Tow conveyor to storage area. Park and chock wheels.

### TO PREPARE CONVEYOR FOR USE AFTER STORAGE:

1. Check tire pressure and inflate to side wall recommendations if necessary.
2. Tow conveyor to work site, being mindful of electrical wires overhead.
3. Replace any damaged parts and decals.
4. Conduct general maintenance procedure before using conveyor.
5. Check belt is tensioned.

**Important:** *Use only genuine Westfield replacement parts or equivalent. Replacement parts such as intake guards, pulley guards, winches, and lift cables MUST MEET ASAE Standards or serious injury may result. Use of unauthorized parts will void warranty. If in doubt, contact Westfield or your Westfield dealer. Do not modify any conveyor components.*

CAUTION	
	Support discharge end of conveyor before removing or replacing any parts on the undercarriage.

# 7. Troubleshooting

The WC1335 Series Grain Conveyor uses an endless flat belt moving through a tube to convey material from one location to another. It is a simple and reliable system that requires minimal maintenance.

If you encounter a problem that is difficult to solve, even after having read through this troubleshooting section, please call your local Westfield dealer or distributor. Before you call, please have this operation manual and the serial number from your machine ready.

## Overall

Problem	Cause	Solution
Low conveying capacity.	<ul style="list-style-type: none"> <li>conveyor angle is too high</li> </ul>	<ul style="list-style-type: none"> <li>re-position with lower tube angle (see Section 8.1.)</li> </ul>
	<ul style="list-style-type: none"> <li>incorrect belt speed</li> </ul>	<ul style="list-style-type: none"> <li>verify and adjust belt speed to appropriate speed (see Section 5.2.)</li> </ul>
	<ul style="list-style-type: none"> <li>conveyor belt slipping</li> </ul>	<ul style="list-style-type: none"> <li>see Section 6.3.3.</li> </ul>
	<ul style="list-style-type: none"> <li>drive belts slipping (Electric Drives Only)</li> </ul>	<ul style="list-style-type: none"> <li>see Section 6.3.7.</li> </ul>
Low capacity for some grains.	<ul style="list-style-type: none"> <li>smaller and smoother grains will slide at shallower angles</li> </ul>	<ul style="list-style-type: none"> <li>see Section 5.2.8. and 8.1.</li> </ul>

## Belt

Problem	Cause	Solution
Belt slipping.	<ul style="list-style-type: none"> <li>conveying belt loose</li> </ul>	<ul style="list-style-type: none"> <li>tighten and align belt (see Section 6.3.3. and 6.3.4.)</li> </ul>
	<ul style="list-style-type: none"> <li>drive roller lagging worn or damaged</li> </ul>	<ul style="list-style-type: none"> <li>replace drive roller lagging</li> </ul>
	<ul style="list-style-type: none"> <li>drive belts loose</li> </ul>	<ul style="list-style-type: none"> <li>tighten and align (see Section 6.3.3. and 6.3.4.)</li> </ul>
	<ul style="list-style-type: none"> <li>belt frozen to tube from operating in high humidity in cold conditions</li> </ul>	<ul style="list-style-type: none"> <li>remove conveyor from area of high humidity and warm belt to de-ice</li> </ul>
Excessive belt edge fraying.	<ul style="list-style-type: none"> <li>belt not aligned</li> </ul>	<ul style="list-style-type: none"> <li>align and tension belt (see Section 6.3.3. and 6.3.4.)</li> </ul>
Belt loose.	<ul style="list-style-type: none"> <li>belt stretches over time</li> </ul>	<ul style="list-style-type: none"> <li>re-tension belt (see Section 6.3.3.)</li> </ul>
		<ul style="list-style-type: none"> <li>can also be caused by oily grain/product</li> </ul>
		<ul style="list-style-type: none"> <li>if tightener is fully engaged, you may need to shorten belt (See Section 6.3.6.)</li> </ul>

**Hopper**

Problem	Cause	Solution
Grain leaking from conveyor hopper.	• belt not tracked (centered)	• track belt (see Section 6.3.4.)
	• flashing installed incorrectly or worn	• inspect flashing for wear and replace if required
	• hopper cloth worn or damaged	• replace damaged hopper cloth
Hopper cloth collapsing under grain.	• misaligned or broken spring(s)	• check spring installation and repair as required
	• pivot shafts improperly installed	• on some machines, switching pivot shafts left to right will increase hopper tension

**Drive**

Problem	Look For	Solution
Drive making noise.	• slipping belt	• see Section 6.3.7.
	• hot shaft, pulley or bearing	• overheated components indicate a failed bearing that must be repaired
	• broken drive roller	• replace damaged component

**Spout**

Problem	Cause	Solution
Grain leaking from conveyor spout between belt and tube.	• belt not tracked (centered)	• track belt (see 6.3.4.)
Grain leaking from conveyor spout between hood and belt.	• belt speed is too fast, hood plugging	• decrease belt speed or feed rate

**Frame**

Problem	Cause	Solution
Conveyor will not stay elevated	• faulty winch	• lower machine to transport position and repair or replace winch
	• faulty cable	• lower machine to transport position and repair or replace cable
Conveyor makes noise while lifting.	• frame parts loose and move while lifting	• replace damaged components and re-tension frame fasteners

**Brackets**

Problem	Cause	Solution
U-clamps sliding on tube.	• clamp not properly crimped to tube	• contact your local dealer for correct positioning

# 8. Appendix

## 8.1. CONVEYOR PRODUCT CHART

The following table indicates the maximum angle a conveyor can move grain.

To roughly determine conveyor angle, use angle guide on right. Stand the manual (vertically) on conveyor s-drive or tube and hold a string with a weight attached to end against the top of this page. Weighted end of string will fall between degree lines, and from this the approximate angle of the conveyor can be determined.

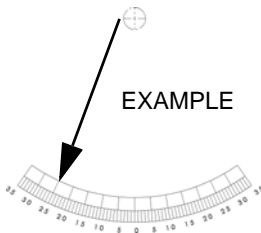

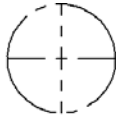

Other Materials	Maximum Conveyor Operating Angle (degrees)
Sawdust	38
Coal	27-45
Wood Chips	>45

Grain	Maximum Conveyor Operating Angle (degrees)
Flax	24
Lentils	29
Mustard	26
Oats	28
Peas	30
Rice	36
Rye	25
Soybeans	28
Sunflower	22
Triticale	23
Wheat	26

Grain	Maximum Conveyor Operating Angle (degrees)
Alfalfa Pellets	34
Barley	25
Canary Seed	26
Canola	25
Chickpeas	30
Corn	26
Shelled Corn (Dry)	25
Shelled Corn (Wet)	28
Cotton Seed	30-45
Durum	25

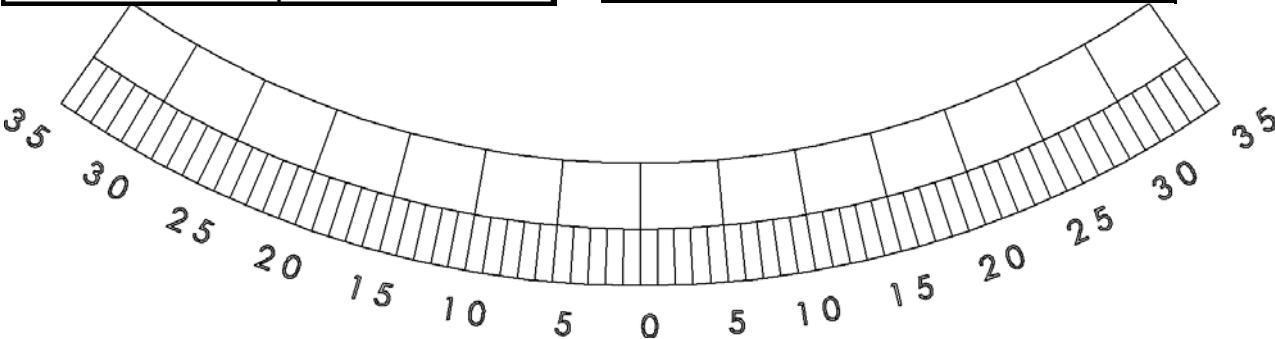

## 8.2. OTHER SPECIFICATIONS

**Table 8.1 Recommended Hydraulic Hose Size**

HOSE:	3/8" DIA Hydraulic hose, 3000 psi rated, 1/2" NPT male solid x 1/2" NPT male solid.
LENGTH:	Minimum 35', depending on location of hydraulic power source.

**Table 8.2 Recommended Pulley Size**

Conveyor Size	Conveyor Pulley	Motor Pulley	*Belt Speed (FT/MIN)
ALL MODELS	15"	4.0"	481
	15"	4.25"	511

\*Speed is calculated using a 1725 rpm electric motor.  
To determine belt speed (ft/min):  
Divide the speed (rpm) of the motor by the outside diameter of the large conveyor pulley, multiply by the outside diameter of the small motor pulley, then multiply by the circumference of the drive rollers (4" diameter). Divide by 12 to get ft/min.  
Example:  
 $1725 \text{ (rpm)} \div 15" \times 4.25" \times (3.14) \times (4") \div 12 \text{ in/ft} = 511 \text{ ft/min}$   
**NOTE:** If a slower belt speed is desired, install a smaller motor pulley.

**Table 8.3 Electric and Hydraulic Configuration Specifications**

CONFIG	"A" UP	"B" UP	"A" DOWN	"B" DOWN	WIDTH	HP REQUIRED	WEIGHT
ELECTRIC	17' (5.18 m)	12-1/2' (3.81 m)	10-1/2' (3.20 m)	13' (3.96 m)	10-1/2' (3.20 m)	5 (1.52 m)	995 lb (451 kg)
HYDRAULIC	17' (5.18 m)	14' (4.26 m)	10' (3.05 m)	15' (4.57 m)	10-1/2' (3.20 m)	N/A <sup>a</sup>	995 lb (451 kg)

- a. Hydraulic motor supplied with hydraulic drive kit. For hydraulic option: H Series motor (4.5 cu. in) requires 12 - 16 gal/min.

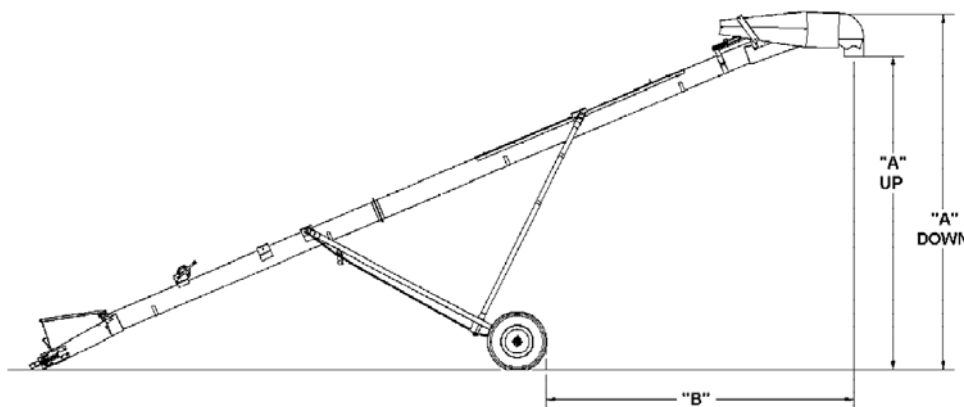

# WARRANTY

Westfield Industries Ltd. warrants products of its manufacture against defects in materials or workmanship under normal and reasonable use for a period of one year after date of delivery to the original purchaser.

Our obligation under this warranty is limited to repairing, replacing, or refunding defective part or parts which shall be returned to a distributor or a dealer of our Company, or to our factory, with transportation charges prepaid. This warranty does not obligate Westfield Industries Ltd. to bear the cost of labor in replacing defective parts. Any defects must be reported to the Company before the end of the one year period.

This warranty shall not apply to equipment which has been altered, improperly assembled, improperly maintained, or improperly repaired so as to adversely affect its performance. Westfield Industries Ltd. makes no express warranty of any character with respect to parts not of its manufacture.

The foregoing is in lieu of all other warranties, expressed or implied, including any warranties that extend beyond the description of the product, and the IMPLIED WARRANTY of MERCHANTABILITY is expressly excluded.

WESTFIELD INDUSTRIES LTD.

ROSENORT, MANITOBA

CANADA

ROG 1W0

***WESTFIELD***<sup>®</sup>

Westfield Industries is a Division of Ag Growth Industries LP

Part of the Ag Growth International Inc. Group

P.O. Box 39

Rosenort, Manitoba, Canada R0G 1W0

Phone: (866) 467-7207 (Canada & USA)

Fax: (866) 768-4852

website: [www.grinaugers.com](http://www.grinaugers.com)

email: [sales@grinaugers.com](mailto:sales@grinaugers.com)

© Ag Growth Industries Limited Partnership 2011

Printed in Canada