

WESTFIELD®

REAR MOUNT DRILL FILL

ALL MODELS

ASSEMBLY AND OPERATIONS MANUAL



Read this manual before using product. Failure to follow instructions and safety precautions can result in serious injury, death, or property damage. Keep manual for future reference.

Part Number: 30265 R1

Revised: Feb/10

TABLE OF CONTENTS

1. Introduction	5
2. Safety First.....	7
2.1. General Safety	8
2.2. Assembly Safety.....	9
2.3. Operation Safety	9
2.4. Hydraulic Safety	9
2.5. Transport and Placement Safety	10
2.6. Maintenance Safety.....	10
2.7. Safety Decal Locations.....	10
2.7.1. Decal Installation	10
2.7.2. Decal Locations	11
3. Assembly	13
3.1. Components	13
3.2. Mounting Brackets.....	14
3.3. Drill Fill Assembly	15
3.4. Adjust Over-Center Lock	16
3.5. Flighting Adjustment	16
3.6. Solenoid Valve & Unload Spout	16
3.7. Electrical Hook-Up.....	17
3.8. Attaching Drill Fill To Truck Box	18
4. Transport.....	21
5. Operation	23
6. Maintenance & Storage.....	25
6.1. Maintenance Procedures	25
6.1.1. Hydraulic Requirements	25
6.1.2. Broken Spring Replacement.....	25
6.2. Storage / Removal of Drill Fill.....	25
7. Troubleshooting	27
Warranty.....	29

1. Introduction

Congratulations. As the new owner of a Westfield Drill Fill Unit, you will be working with equipment designed to complement and improve your farming operation. Before using the drill fill, please read this manual and familiarize yourself with the machine and the necessary precautions for efficient and safe operation. Anyone assembling this equipment should also be familiar with all safety precautions.

The hydraulic motor requires a minimum of 8 gpm and a maximum of 12 gpm at 1400 psi to function properly. The drill fill must be grounded to the truck frame.

Thank you.

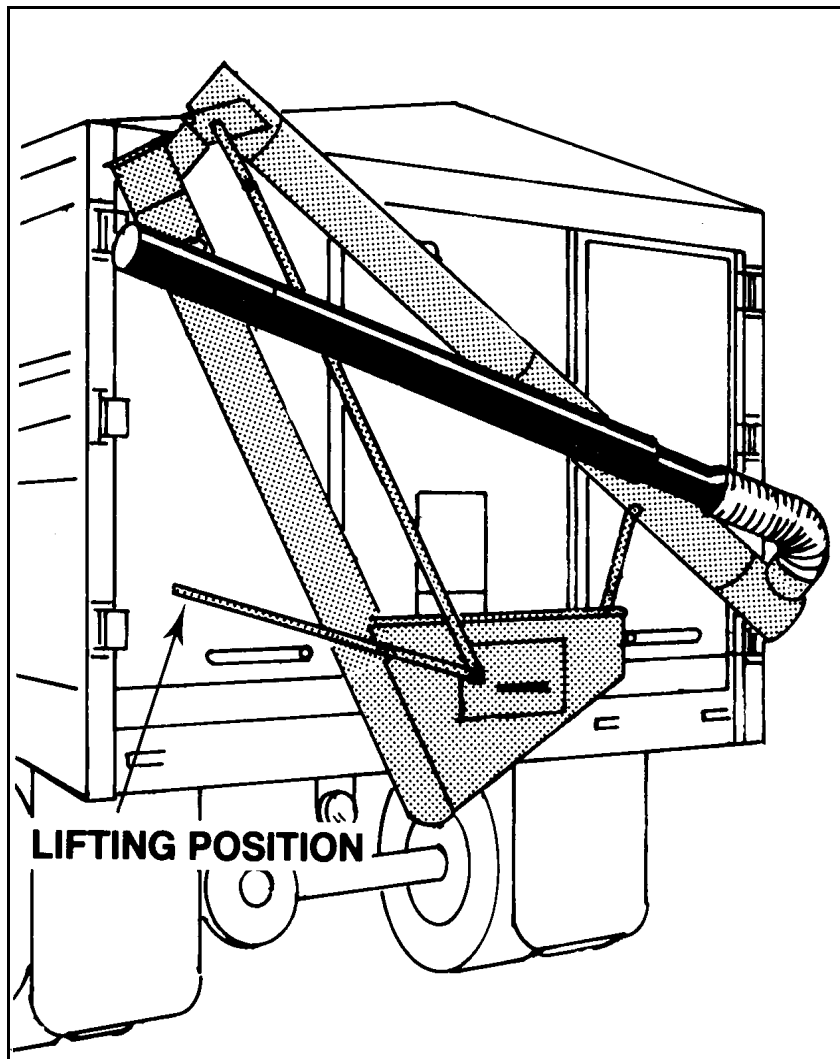

2. Safety First



The Safety Alert symbol to the left identifies important safety messages on the product and in the manual. When you see this symbol, be alert to the possibility of personal injury or death. Follow the instructions in the safety messages. Why is SAFETY important to you?

Three big reasons:

- Accidents disable and kill.
- Accidents cost.
- Accidents can be avoided.

SIGNAL WORDS

Note the use of the signal words **DANGER**, **WARNING**, **CAUTION**, and **NOTICE** with the safety messages. The appropriate signal word for each message has been selected using the definitions below as a guideline.

The Safety Alert symbol means ATTENTION, BE ALERT!, YOUR SAFETY IS INVOLVED.

DANGER



Indicates an imminently hazardous situation that, if not avoided, will result in serious injury or death.

WARNING



Indicates a hazardous situation that, if not avoided, could result in serious injury or death.

CAUTION



Indicates a hazardous situation that, if not avoided, may result in minor or moderate injury.

NOTICE

Indicates a potentially hazardous situation that, if not avoided, may result in property damage.

2.1. GENERAL SAFETY

Important: *The general safety section includes instructions that apply to all safety practices. Any instructions specific to a certain safety practice (e.g., assembly safety), can be found in the appropriate section. Always read the complete instructional sections and not just these safety summaries before doing anything with the equipment.*

YOU are responsible for the **SAFE** use and maintenance of your equipment. **YOU** must ensure that you and anyone else who is going to work around the equipment understands all procedures and related **SAFETY** information contained in this manual.

Remember, **YOU** are the key to safety. Good safety practices not only protect you, but also the people around you. Make these practices a working part of your safety program.

- It is the equipment owner and the operator's responsibility to read and understand **ALL** safety instructions, safety decals, and manuals and follow them before assembling, operating, or maintaining the equipment. All accidents can be avoided.
- Equipment owners must give instructions and review the information initially and annually with all personnel before allowing them to operate this product. Untrained users/operators expose themselves and bystanders to possible serious injury or death.
- Use this equipment for its intended purposes only.
- Do not modify the equipment in any way. Unauthorized modification may impair the function and/or safety, and could affect the life of the equipment. Any modification to the equipment voids the warranty.
- Do not allow children, spectators, or bystanders within the work area.
- Have a first-aid kit available for use should the need arise, and know how to use it.
- Provide a fire extinguisher for use in case of an accident. Store in a highly visible place.
- Wear appropriate protective gear. This list includes, but is not limited to:
 - a hard hat
 - gloves
 - protective shoes with slip-resistant soles
 - protective goggles
 - hearing protection
- For Powered Equipment: before servicing, adjusting, or repairing powered equipment, unplug, place all controls in neutral or off position, stop the engine or motor, remove ignition key or lock out power source, and wait for all moving parts to stop.



- Follow good shop practices:
 - keep service area clean and dry
 - be sure electrical outlets and tools are properly grounded
 - use adequate light for the job at hand
 - Think SAFETY! Work SAFELY!



2.2. ASSEMBLY SAFETY

- Read through the instructions to get to know the sub-assemblies and hardware that make up the equipment.
- Do not take chances with safety. The components are large, heavy, and can be hard to handle. Always use the proper tools, stands, jacks, and hoists for the job.
- Always have 2 or more people assembling the equipment. Because of the weight, do not attempt assembly alone.

2.3. OPERATION SAFETY

- Have another person nearby who can shut down equipment in case of an accident.
- The drill fill auger is not insulated. Keep away from all electric lines and devices. Electrocution can occur without direct contact.
- During operation, always ensure that all safety guards, cleanout covers, and dump covers are in place. Also make sure that the retaining pin securing the cleanout door latch is in place.
- Before starting truck, make sure all power (electrical and hydraulic) to the drill fill auger is off.
- Keep body, hair, and clothing away from moving parts.
- Stay away from hopper during operation.
- Clear all personnel when raising or lowering upper tube section.
- Be aware of the weight shift when raising or lowering upper tube section. Keep a firm grip on the lift handle.

2.4. HYDRAULIC SAFETY

- Wear proper hand and face protection when searching for hydraulic leaks. Escaping fluid under pressure can penetrate the skin, causing serious injury like gangrene. In case of accident, see a doctor immediately.
- Do not disconnect hydraulic couplers when hydraulic system is pressurized. For the correct procedure, consult this manual or your tractor manual.
- Relieve pressure before unhooking hydraulic lines.
- Inspect hydraulic fittings and hoses for damage on a daily basis. Repair if damaged.
- Ensure that the hydraulic line is properly connected and secure.

- Keep hydraulic line away from moving parts.
- Clean connections before connecting to equipment.

2.5. TRANSPORT AND PLACEMENT SAFETY

- Empty auger tube before lowering into transport position.
- Lower upper tube section to transport position at completion of operation or when not in use. Do not transport with upper tube in raised position.

2.6. MAINTENANCE SAFETY

- Shut down and lock out all power before attempting maintenance of any kind. If applicable, disconnect PTO driveline from tractor or hydraulic hoses on units with hydraulic drive hoppers.
- After maintenance is complete, replace and secure all safety guards and safety devices, and if applicable, service doors and cleanout covers.
- Use only genuine Westfield replacement parts or equivalent. Replacement parts such as intake guards, pulley guards, PTO driveline shields, winches, and lift cables must meet ASAE standards or serious injury may result. Use of unauthorized parts will void warranty. If in doubt, contact Westfield or your Westfield dealer. Do not modify any auger components.

2.7. SAFETY DECAL LOCATIONS

- Keep safety decals clean and legible at all times.
- Replace safety decals that are missing or have become illegible. See decal location figures below.
- Replaced parts must display the same decal(s) as the original part.
- Safety decals are available from your distributor, dealer, or factory.

2.7.1. DECAL INSTALLATION

1. Decal area must be clean and dry, with a temperature above 10°C (50°F).
2. Decide on the exact position before you remove the backing paper.
3. Align the decal over the specified area and carefully press the small portion with the exposed sticky backing in place.
4. Slowly peel back the remaining paper and carefully smooth the remaining portion of the decal in place.
5. Small air pockets can be pierced with a pin and smoothed out using the sign backing paper.

2.7.2. DECAL LOCATIONS

Replicas of the safety decals that are attached to the equipment are shown below. Good safety requires that you familiarize yourself with the various safety decals and the areas or particular functions that the decals apply to as well as the safety precautions that must be taken to avoid serious, injury, death, or damage.

** Westfield reserves the right to update safety decals without notice. Safety decals may not be exactly as shown.*

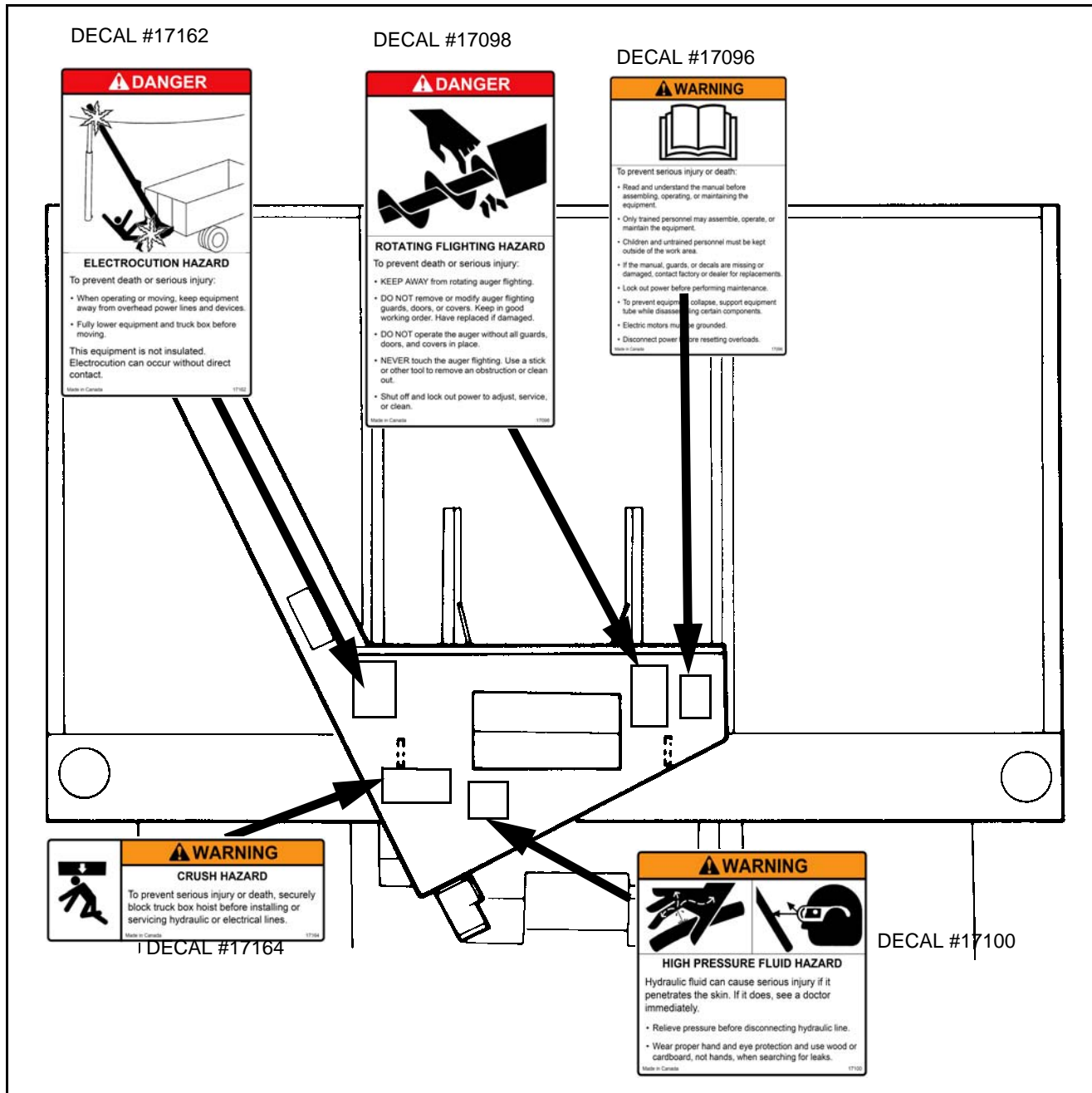

Figure 2.1

3. Assembly

Warning: Before continuing, please reread the safety information relevant to this section at the beginning of this manual. Failure to follow the safety instructions can result in serious injury, death, or property damage.

Before starting assembly familiarize yourself with all the sub-assemblies and hardware. Arrange all parts for easy access. Carry out assembly in a large open area with a level surface.

Important: Always have 2 or more people assembling the equipment. Because of the weight, do not attempt assembly alone.

3.1. COMPONENTS

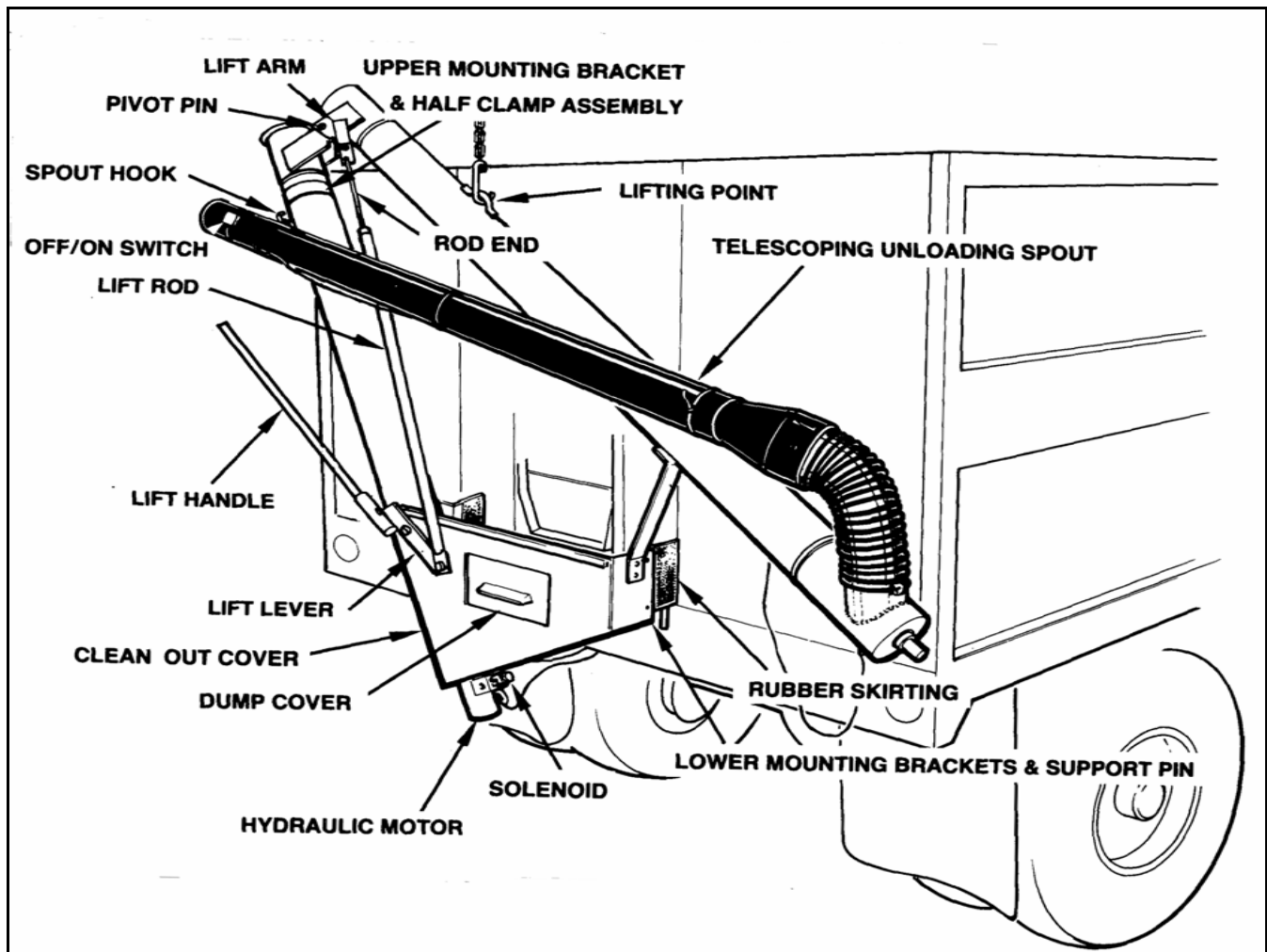

3.2. MOUNTING BRACKETS

Install mounting brackets prior to installing the drill fill.

1. Lift the hopper section of the drill fill and slide the lip of the hopper under center gate at rear of truck box. Tie or hold drill fill in place while marking mounting holes.
 2. Insert long support pin through lower mounting brackets and welded tabs on back of drill fill hopper. Position mounting brackets on outside of tabs if you can, or as far apart as possible.
 3. Mark the lower mounting bracket hole locations on the truck box.
 4. Attach the 2 half clamps (with pin pointing down) to upper end of the hopper tube section with two $7/16"$ x 1" bolts and locknuts.
 5. With the half-clamp assembly as high as possible on the tube, rotate clamps until the pin is in a vertical position. Tighten bolts.
 6. Slip upper mounting bracket on half clamp pin and mark the 2 holes.
- Important:** *The lower tube section of the drill fill must be parallel to the truck box end gate. Shim up the upper mounting bracket if necessary. You may need a longer bolt (not provided).*
7. Remove hopper section from truck box and drill four $29/64"$ holes at the marked locations.
 8. Secure the lower and upper mounting brackets to truck box with four $7/16"$ x 1" bolts and locknuts.

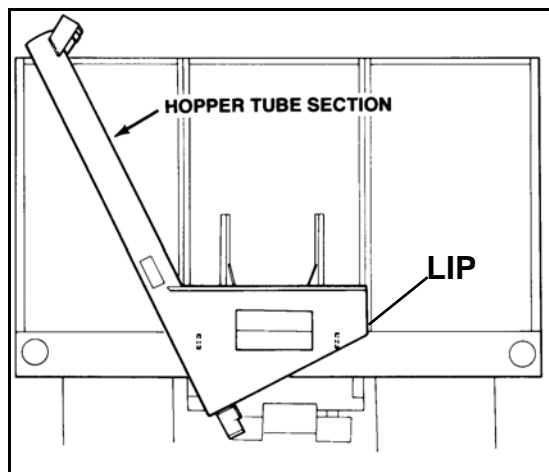

Figure 3.1 Hopper Tube Section

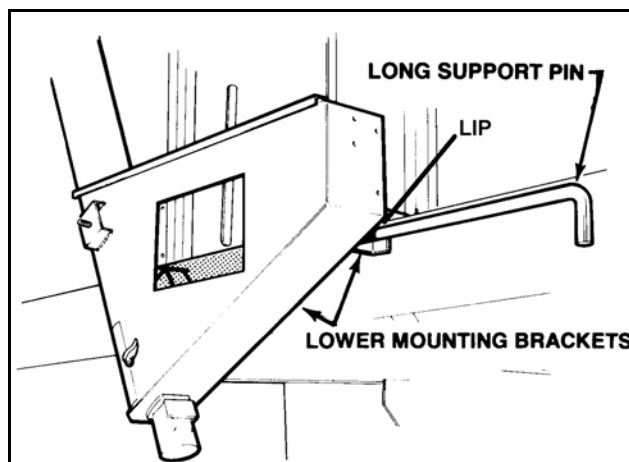

Figure 3.2 Lower Mounting Bracket Locator

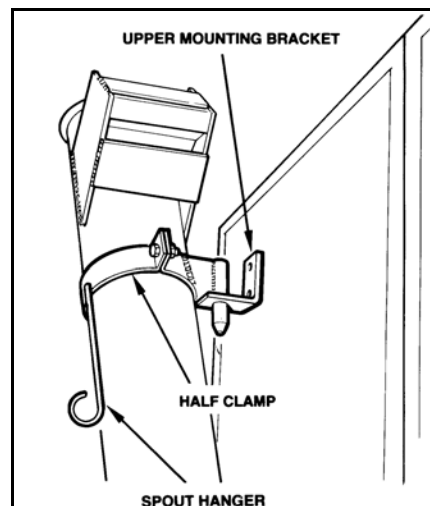

Figure 3.3

3.3. DRILL FILL ASSEMBLY

1. On a level surface, lay upper tube next to lower tube (Figure 3.4).
2. Stack the 3 springs with large coil over spacer pipe and insert spring ends through end plate holes in upper pivot bracket.
3. Align pivot holes of upper and lower tube sections. Insert a 5/8" x 7-1/4" pin through pivot holes and through the spacer pipe. Secure with cotter pins.
4. Insert the other 5/8" pin through loop hole in lower tube pivot bracket and through loops on the 3 springs. Secure 5/8" pin with cotter pins.

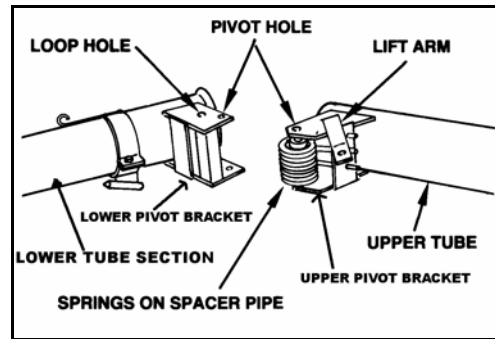

Figure 3.4 Springs on Spacer Pipe

Important: *This 5/8" pin must go through the loops on the springs.*

5. Slip a 5/8" flat washer and the lift lever onto welded bolt on the hopper (Figure 3.5) and secure with a 5/8" locknut. Tighten snug only, as this acts as a pivot point.
6. Attach the lift rod to lift lever (Figure 3.5) with a 5/8" x 1-1/2" bolt and locknut. Tighten snug only; this bolt acts as a pivot point.
7. Thread a 5/8" jam nut onto the threaded rod end, then screw rod end into top threaded end of the lift rod.
8. Secure the upper support brace to hopper with two 3/8" x 1" bolts and whiz-nuts.

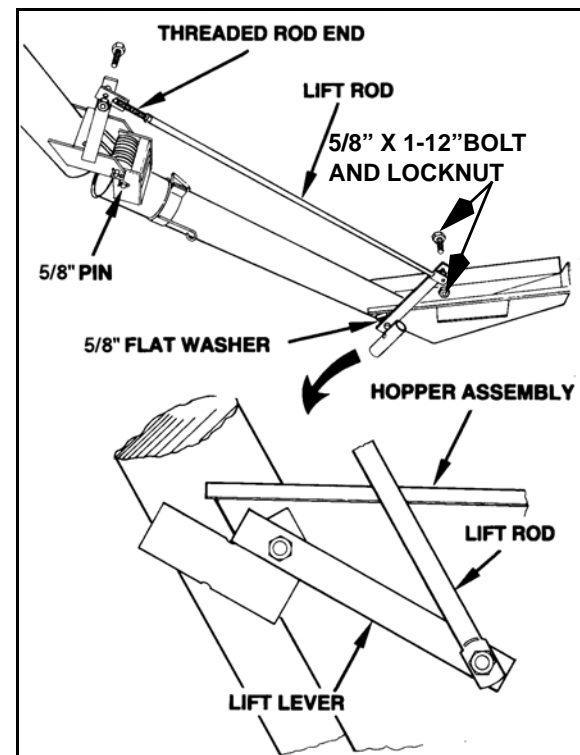

Figure 3.5 Threaded Rod End

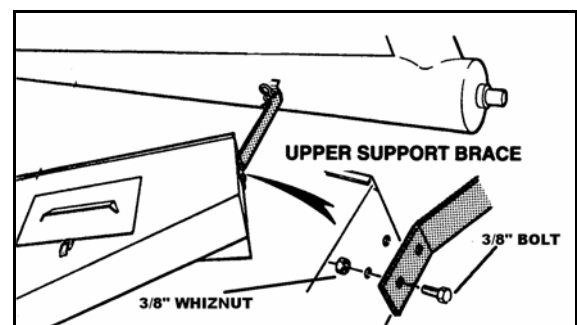

Figure 3.6 Upper Support Brace

3.4. ADJUST OVER-CENTER LOCK

1. Pull upper tube into operating position.
2. Adjust threaded rod end and secure to lift rod on upper tube with a 5/8" x 1-1/2" bolt and locknut. Repeat this procedure until upper tube over-center locks into operating position with some tension on the lift handle.
3. After adjustment is complete, tighten the 5/8" jam nut on rod end. The 5/8" x 1-1/2" bolt and locknut should be tightened snug only, as this bolt acts as a pivot point.

3.5. FLIGHTING ADJUSTMENT

1. With upper tube locked into operating position, remove the lock collar on top bearing.
2. Push upper flight down until it meets the lower flight. Reach into outlet spout on upper tube and rotate upper flight to ensure it is fully engaging with the lower flight.
3. Replace and secure lock collar on top bearing.

NOTICE

To prevent damage to the auger:
when the drill fill is in operating position, the upper flight
must fully engage with the lower flight.

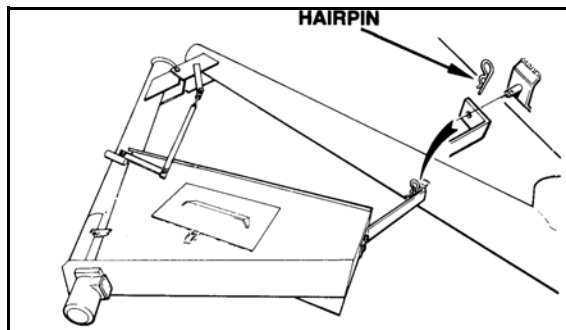

Figure 3.7 Hairpin

4. Pull upper tube into transport position with pin fitting through upper tube support brace. Lock into place with a hairpin. Because of the spring tension, one person should hold hopper while another pulls and locks upper tube into transport position.

3.6. SOLENOID VALVE & UNLOAD SPOUT

1. Remove protective cover plate from the hydraulic motor and discard.
2. Ensure the o-rings are properly seated in oil ports on hydraulic motor. Remove plastic hole covers from ports on solenoid.

3. Position solenoid with side marked "P" or "IN" over "Port A" on hydraulic motor and secure solenoid with four 5/16" x 2-3/4" bolts (Figure 3.8 and 3.9).

Important: For correct rotation on the auger flight, connect the hydraulic input hose from truck to port marked "P" or "IN" on solenoid (Figure 3.9), and the hydraulic return hose to the port on opposite side of solenoid.

4. Slip flexible portion of the telescopic unload spout over auger outlet. Secure with 3 concave washers and 1/4" x 3/4" self-tapping screws.

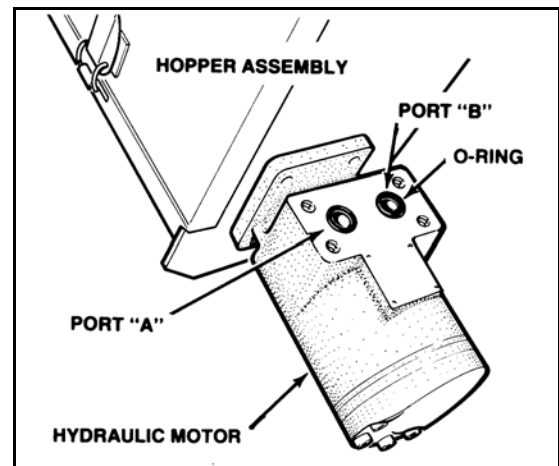

Figure 3.8 Hopper Assembly

3.7. ELECTRICAL HOOK-UP

1. Connect either of the two wires on the solenoid to one of the wires on the wiring harness and cover the connection with electrical tape.

Important: The other wire on solenoid is the ground wire. The solenoid must be properly grounded. See step 7. on page 19.

2. Leaving some slack at the solenoid, route the wiring harness up the back side of hopper and tube sections, outside the pivot brackets. Secure with 7 nylon ties (Figure 3.10).

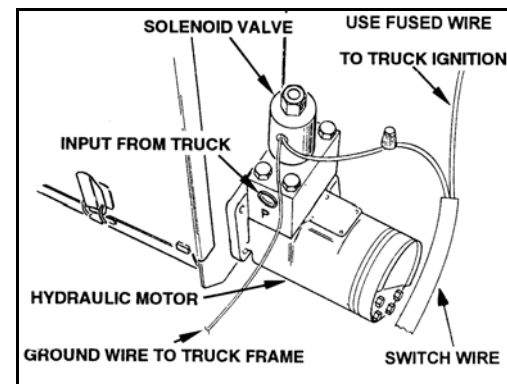

Figure 3.9 Motor Wires

NOTICE

Leave adequate slack in the wiring harness at the pivot point to ensure that wiring will not be damaged when upper tube is raised and lowered.

WARNING



Securely block truck box hoist if box is raised to install or service hydraulic or electrical lines to prevent unintentional lowering. Failure to heed will result in serious injury.

3. Mount OFF/ON switch to the pre-drilled holes near the telescopic unload spout handle with two 1/4" x 1/2" bolts and whiznuts (Figure 3.10).

4. Secure the wiring harness to telescopic unload spout with nylon ties (Figure 3.10).

Note: Leave some slack in the wiring harness at the flexible portion of unload spout with the spout fully extended.

5. Install dump cover and secure in place.
6. Loop the spout handle to welded hook on the clamp.

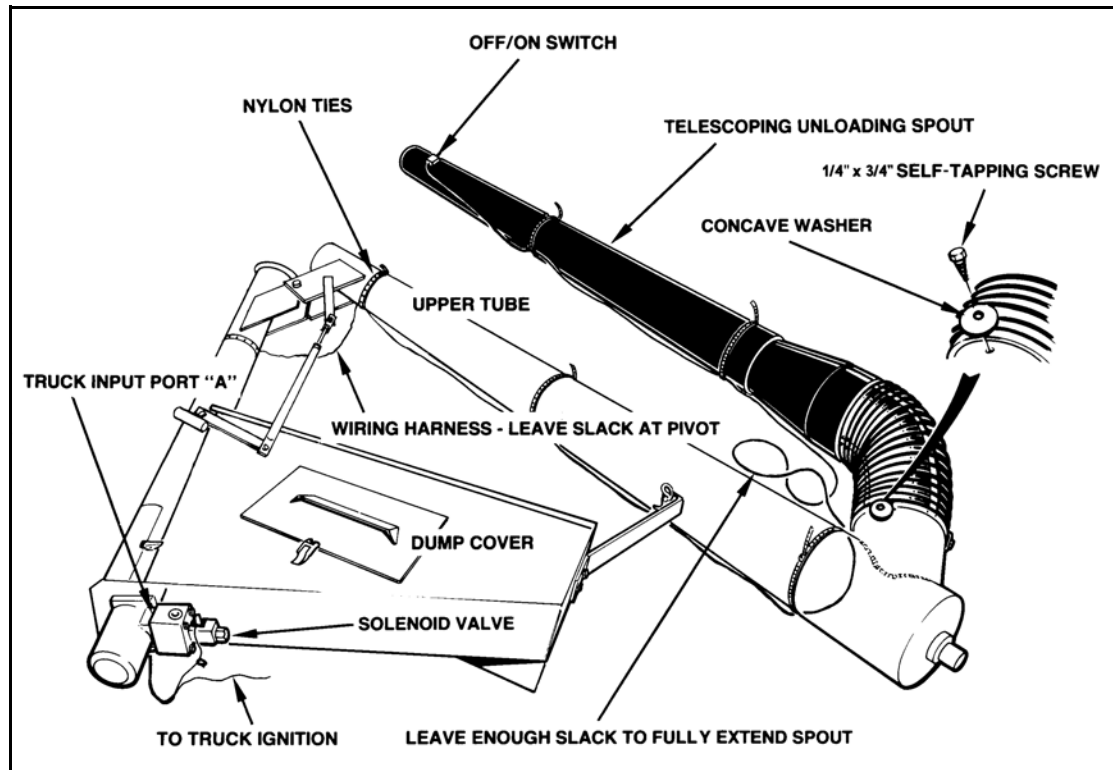

Figure 3.10 Switch

3.8. ATTACHING DRILL FILL TO TRUCK BOX

The drill fill weighs about 220 lb. Although it can be lifted in place by hand, it is not recommended. A looped rod welded to the upper tube is the lifting point for the drill fill.

1. Fasten a chain at the lifting point and hoist drill fill into position.
2. Insert pin on tube clamp into upper mounting bracket, then secure hopper section to lower mounting bracket with the long support pin and install hairpin.
3. Install rubber skirting at each hopper end with 5/16" x 3/4" bolts and whiznuts. To ensure a snug fit, trim the skirting if necessary.
4. Install a 3/8" hydraulic pressure line from truck hydraulic system to port marked "P" or "IN" on the solenoid, and a 3/8" return line from opposite solenoid port to the return port on truck hydraulic system.

Note: The 3/8" hydraulic hose, pipe, couplers, and 3/8" - 18 NPTF male fittings to be supplied by customer.

5. **Optional:** Install quick couplers in the pressure and return lines at back of truck box or frame. This will reduce time needed to attach and remove drill fill. Protect hydraulic fittings from dirt and dust when disconnected.

Important: Use teflon tape or pipe stick (not supplied) on all hydraulic fittings except where o-rings are used.

6. Run a 4 amp fused power wire (not supplied) from truck ignition to the loose wire on wiring harness. Cover connection with electrical tape.
7. Connect a ground wire from truck frame to loose wire on solenoid. Make sure wire connecting areas are free of paint, oil and dirt.

Important: Drill Fill **MUST** be grounded. Connect a ground wire from truck frame to loose wire on solenoid. Ensure wire connecting areas are free of paint, oil and dirt. Do not ground to truck box: grease on hinge pins may prevent grounding.

8. **Optional:** Install quick-connect electrical connectors on both the power and ground wires. This will reduce time needed to attach and remove the drill fill. Protect wire ends and connectors to prevent electrical shorting.

With drill fill mounted on truck, raise into operating position. Be aware of weight shift. Check that the over-center lock is properly adjusted. Also ensure that upper and lower flights engage fully.

Important: Use only genuine Westfield replacement parts or equivalent. Replacement parts must meet ASABE standards or serious injury may result. Use of unauthorized parts will void warranty. If in doubt, contact Westfield or your Westfield dealer. Do not modify any auger components.

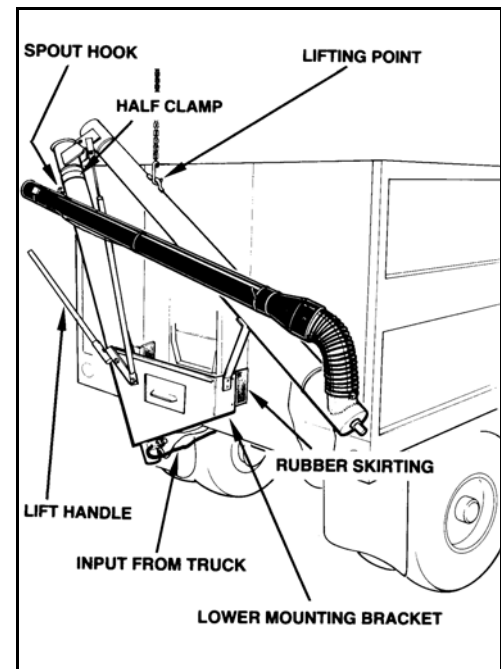

Figure 3.11 Lower Mounting Bracket

4. Transport

Warning: Before continuing, please reread the safety information relevant to this section at the beginning of this manual. Failure to follow the safety instructions can result in serious injury, death, or property damage.

Drill fill must be locked into transport position before transporting, refer to Figure 4.1.

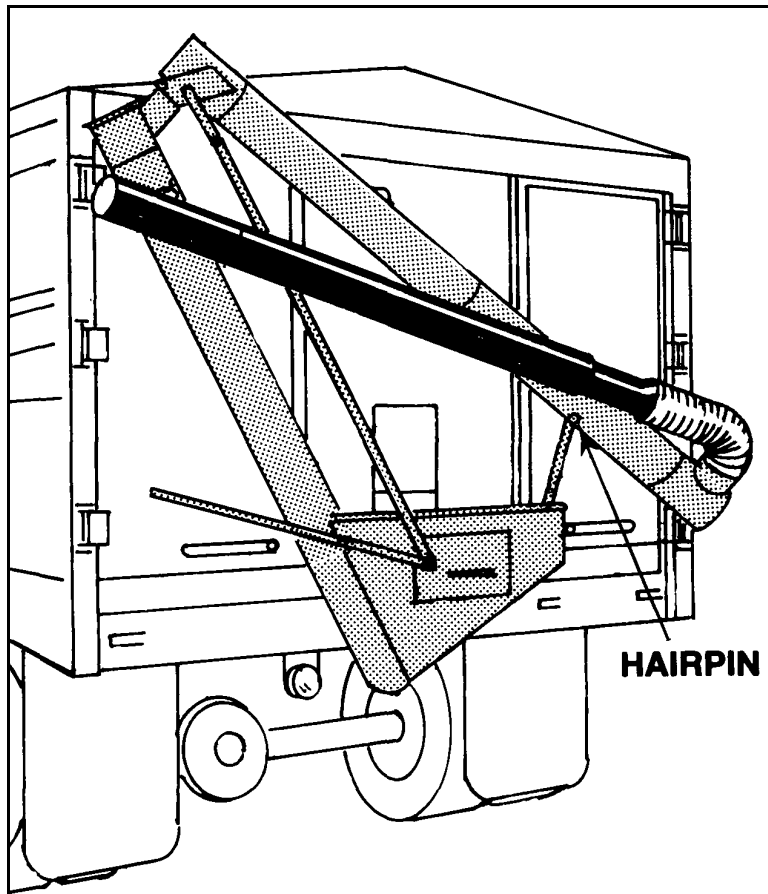

Figure 4.1 Hairpin Location

CAUTION



When raising or lowering upper tube section, be aware of weight shift. Keep firm grip on lift handle.

5. Operation

Warning: Before continuing, please reread the safety information relevant to this section at the beginning of this manual. Failure to follow the safety instructions can result in serious injury, death, or property damage.

Operators must observe safety procedures at all times and follow the pre-operational checklist before each start-up.

Pre-Operation Checklist

Before operating auger each time, the operator must confirm the following:

- All fasteners are secure as per assembly instructions.
- Hydraulic hoses are in good condition.
- Hydraulic connections are in place and secure.
- Cleanout cover is closed and secured with retaining pin, and dump cover is in place and secure.
- Tube alignment is reasonably straight.
- Intake area and discharge spout are free of obstructions.
- Proper maintenance has been performed.

Important: *In order to maintain proper grain flow through the discharge spout, hold spout at no less than 45° to horizontal during operation. A more shallow angle could plug the downspout resulting in damage to the equipment.*

CAUTION



Do not allow tube to drop, it will result in damage to tube and serious personal injury. Keep firm grip on lift handle.

WARNING



Do not operate if clean-out door is open or removed.

TO UNLOAD MATERIAL FROM TRUCK:

1. Drive close to seeding equipment.
2. Remove hairpin, raise, and over-center lock drill fill into operating position.
3. Slip handle onto opposite end of welded rod and secure with hairpin to prevent bending when raising truck box.
4. Switch on hydraulic power, raise truck box, and open end gate.

On drill fill augers equipped with bristle flighting, reduce flow of material to hopper or plugging will occur.

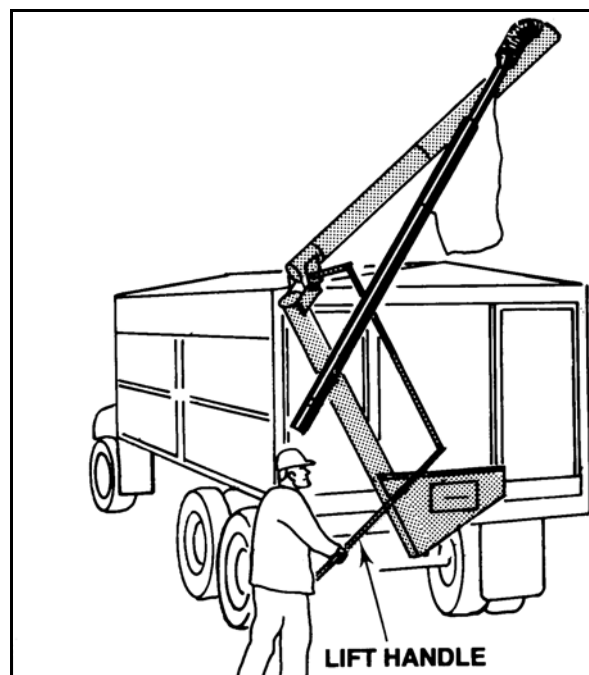

Figure 5.1 Lift Handle

5. Position telescopic unload spout and flick switch on.
6. Close truck end gate just before seeding equipment is full and empty drill fill of seed or fertilizer back into truck box. Shut off auger and open cleanout door to remove final excess material. Do not use hands to clean out, use a stick or other tool.
7. Upon completion, lower and lock drill fill in transport position.
8. After use with fertilizer, use pressurized water to wash out auger and hopper.

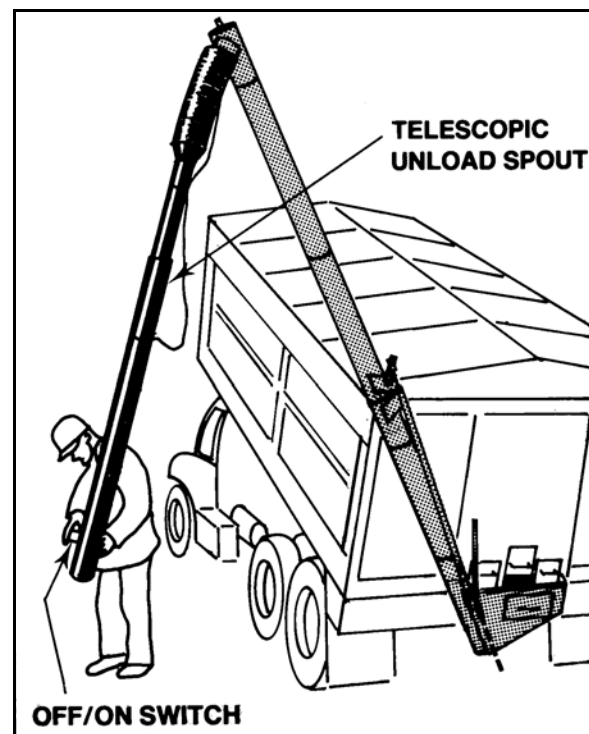

Figure 5.2 Unload Spout

DANGER



NEVER touch the auger flighting. Use a stick or other tool to remove an obstruction or clean out.

6. Maintenance & Storage

Warning: Before continuing, please reread the safety information relevant to this section at the beginning of this manual. Failure to follow the safety instructions can result in serious injury, death, or property damage.

6.1. MAINTENANCE PROCEDURES

6.1.1. HYDRAULIC REQUIREMENTS

The hydraulic motor requires a minimum of 8 gpm and a maximum of 12 gpm at 1400 psi to function properly.

Oil flow in excess of 12 gpm will cause augers to creep when spout switch is shut off, and will require the installation of a flow control valve. See "Assembly" on page 13. for correct hook up of hydraulics.

6.1.2. BROKEN SPRING REPLACEMENT

1. If it becomes necessary to replace springs, lock drill fill in transport position, remove from truck, and lay flat on the ground.
2. Place upper tube section halfway between the transport and operating positions. (See Section 3.3.)
3. With tension removed from springs, remove both 5/8" x 7-1/4" pins and separate upper and lower tube sections slightly. Remove broken springs.
4. Stack 3 good springs with large coil over spacer pipe and insert spring ends through end plate holes in upper pivot bracket (Section 3.3.).
5. Align pivot holes. Insert a 5/8" x 7-1/4" pin through pivot holes and through the spacer pipe. Secure with cotter pins.
6. Insert other 5/8" x 7-1/4" pin through loop hole in lower-tube pivot bracket and through loops on the 3 springs. Secure with cotter pins.
7. Pull upper tube into transport position and lock into place with hairpin.

6.2. STORAGE / REMOVAL OF DRILL FILL

Note: *To attach the drill fill, see Section 3.8.*

Lock drill fill in transport position before removing from or attaching to truck box.

1. Before removing drill fill, use pressurized water to thoroughly wash inside auger tube and hopper. Allow water to drain and dry.
2. Disconnect hydraulic and electrical lines. Place protective covers over connections.

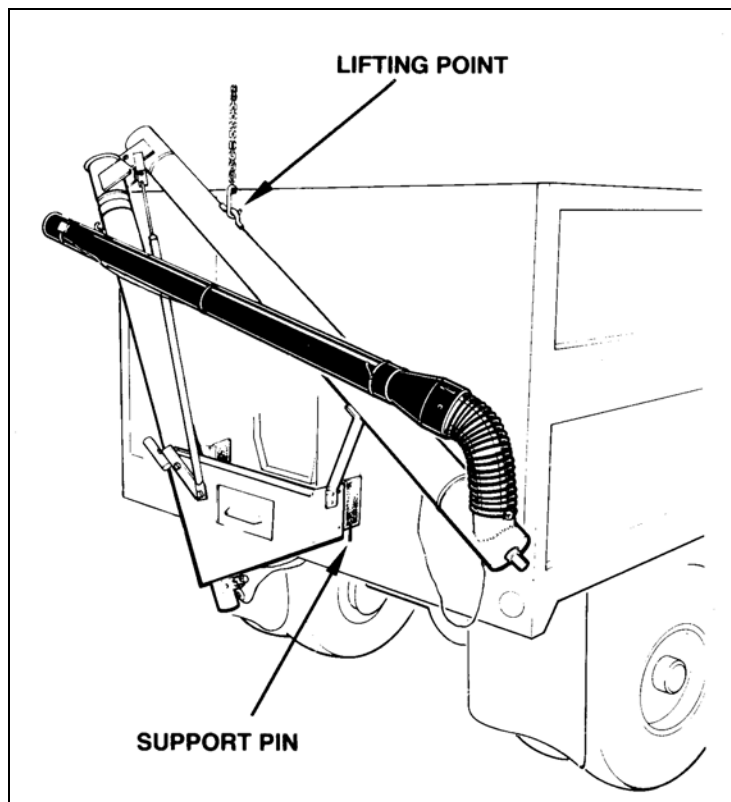

Figure 6.1 Support Pin Location

3. Using a suitable hoist, connect chain hook to lift point on upper tube.
4. Remove the long support pin at bottom of hopper. Swing bottom of drill fill away from truck box, then raise drill fill until welded pin on half clamp clears the upper mounting bracket.
5. Move drill fill away from truck and store in the flat position.

7. Troubleshooting

Problem	Possible Cause	Remedy
Auger runs too slow.	Truck engine running too slow.	Increase engine speed.
	Truck pump not producing minimum required flow and pressure.	Check pump capacity.
	Hydraulic auger motor worn.	Repair or replace.
	Solenoid incorrectly installed.	Follow instructions as per manual.
	Hydraulic hoses too small.	Use minimum 3/8" hose.
Auger won't run.	Auger jammed.	Shut down and lock out power. Clear obstructions, ensuring unload spout is clear.
	Upper and lower flightings not meshing properly.	Check to see if flight engagement mechanism has been damaged. Adjust flighting as per manual.
	No hydraulic pressure to motor.	Check for correct attachment of hydraulic hoses and routing.
	No power to solenoid.	Check for burned fuse, poor ground to solenoid, or broken connections.
	Ports between hydraulic motor and solenoid blocked.	Remove solenoid and clear out obstructions.
	Solenoid mounted wrong.	Mount solenoid as per manual instructions.
Oil leaking at motor and solenoid connection.	Solenoid bolts loose.	Tighten bolts.
	O-rings damaged or not properly installed.	Remove solenoid and check that o-rings are correctly installed. Replace if damaged.
Auger creeps when spout switch is shut off.	Oil flow is too high	Decrease oil flow to hydraulic motor with use of a flow control valve. Flow must not exceed 12 gallons per minute.
Solenoid won't function.	Poor ground.	Attach ground wire from solenoid to truck frame.
	Solenoid mounted incorrectly.	Mount solenoid as per manual instructions.

WARRANTY

Westfield Industries Ltd. warrants products of its manufacture against defects in materials or workmanship under normal and reasonable use for a period of one year after date of delivery to the original purchaser.

Our obligation under this warranty is limited to repairing, replacing, or refunding defective part or parts which shall be returned to a distributor or a dealer of our Company, or to our factory, with transportation charges prepaid. This warranty does not obligate Westfield Industries Ltd. to bear the cost of labor in replacing defective parts. Any defects must be reported to the Company before the end of the one year period.

This warranty shall not apply to equipment which has been altered, improperly assembled, improperly maintained, or improperly repaired so as to adversely affect its performance. Westfield Industries Ltd. makes no express warranty of any character with respect to parts not of its manufacture.

The foregoing is in lieu of all other warranties, expressed or implied, including any warranties that extend beyond the description of the product, and the IMPLIED WARRANTY of MERCHANTABILITY is expressly excluded.

WESTFIELD INDUSTRIES LTD.

ROSENORT, MANITOBA

CANADA

ROG 1W0

WESTFIELD

Westfield is a Division of Ag Growth Industries LP

Part of the Ag Growth International Inc. Group

P.O. Box 39

Rosenort, Manitoba, Canada R0G 1W0

Phone: (866) 467-7207 (Canada & USA)

Fax: (866) 768-4852

website: www.grainaugers.com

email: sales@grainaugers.com

© Ag Growth Industries Limited Partnership 2009

Printed in Canada