

# WESTFIELD®

## TFX SERIES GRAIN AUGERS

831, 836, 841, 846, 851, 1031, 1036, & 1041 MODELS  
ASSEMBLY & OPERATION MANUAL

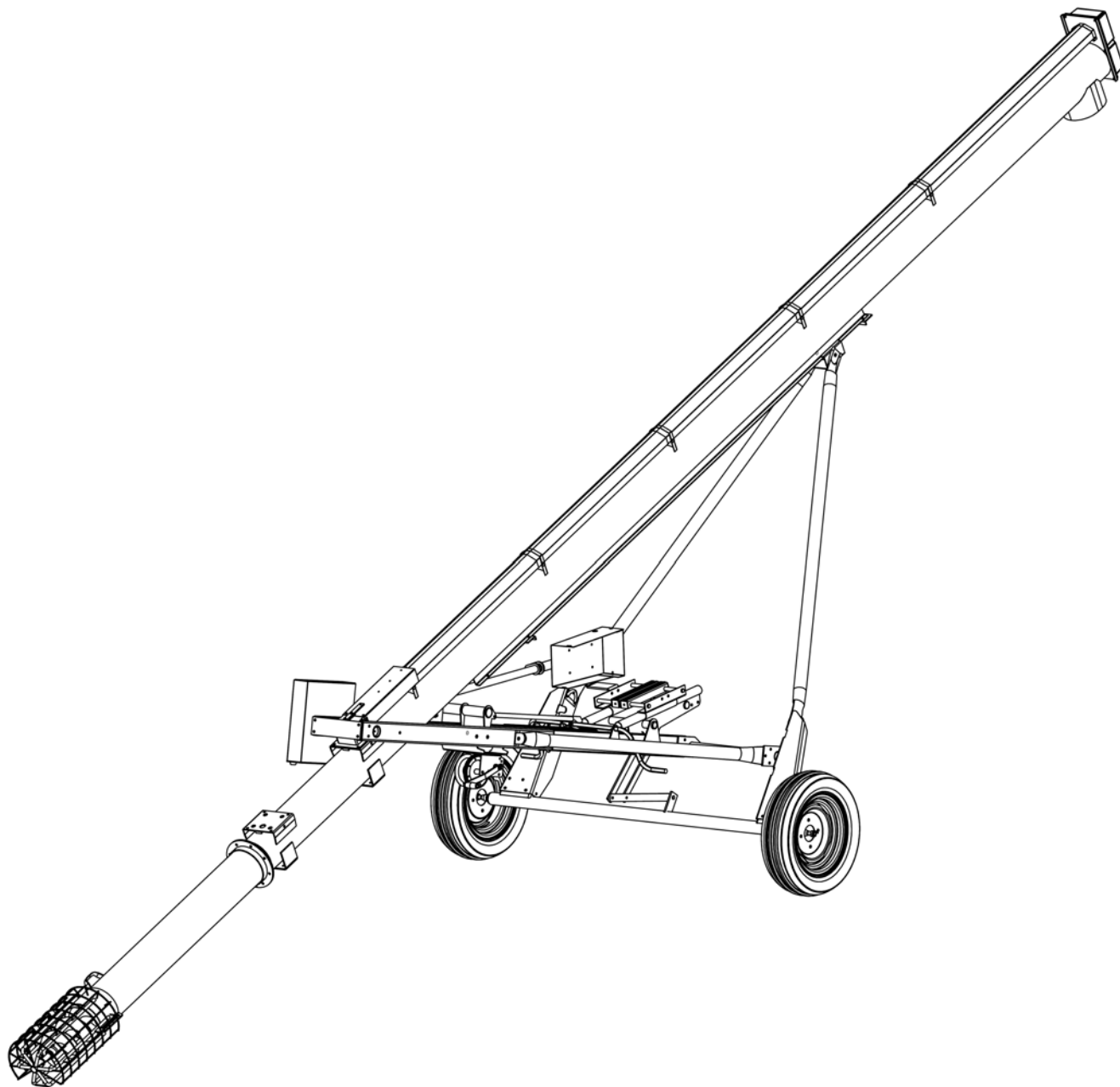

Read this manual before using product. Failure to follow instructions and safety precautions can result in serious injury, death, or property damage. Keep manual for future reference.

Part Number: 30666 R1

Revised: 30/8/10



# TABLE OF CONTENTS

<b>1. Introduction .....</b>	<b>5</b>
<b>2. Safety First.....</b>	<b>7</b>
2.1. General Safety .....	8
2.2. Assembly Safety.....	9
2.3. Transport & Placement Safety .....	9
2.4. Operation Safety .....	10
2.5. PTO Safety .....	12
2.6. Gas Engine Safety .....	12
2.7. Electric Motor Safety .....	12
2.8. Battery Safety .....	12
2.9. Maintenance Safety.....	12
2.10. Safety Decal Locations.....	13
2.10.1. Decal Installation .....	13
2.10.2. Decal Locations .....	13
<b>3. Assembly .....</b>	<b>17</b>
3.1. Tubes & Flighting .....	17
3.2. Track Shoe & Trackstop.....	18
3.3. Intake Hitch .....	20
3.4. Driveshaft .....	20
3.5. Gearbox.....	21
3.6. Driveshaft Guard .....	22
3.7. Truss .....	22
3.8. Transport Undercarriage .....	24
3.9. Winch & Lift Cable.....	28
3.10. Winch Handle .....	30
3.11. Winch Cable Routing.....	31
3.12. Gas / Electric Motor Mount Installation.....	32
3.13. PTO Drive Installation (Optional).....	38
3.14. Battery Mount (Optional) .....	43
3.15. Gas Tank Mount.....	44
3.16. Upper Housing Lubrication .....	44
3.17. Plastic Manual Holder .....	44
<b>4. Transport &amp; Placement .....</b>	<b>45</b>
4.1. Transport Procedure .....	45
4.2. Placement Procedure .....	46

# TABLE OF CONTENTS

<b>5. Operation .....</b>	<b>49</b>
5.1. Pre-Operational Checklist.....	49
5.2. Auger Drive & Lockout Procedure .....	49
5.3. Operating Procedure .....	50
5.3.1. Start-Up & Break-In .....	50
5.3.2. Operating With A Full Load.....	51
5.3.3. Shutdown.....	52
5.3.4. Lowering & Completion.....	52
5.4. Horsepower Requirements.....	53
<b>6. Maintenance &amp; Storage.....</b>	<b>55</b>
6.1. General Maintenance Procedures.....	55
6.2. General Storage Procedures.....	57
<b>7. Troubleshooting .....</b>	<b>59</b>
Warranty.....	61

# 1. Introduction

Congratulations. As the new owner of a grain auger, you will be working with equipment designed to complement and improve your farming operation. Before using this auger, please read this manual and all safety labels and familiarize yourself with the various features of the machine and the necessary precautions for efficient and safe operation.

In addition, anyone using this auger is required to comply with all safety precautions in this manual and in safety labels attached to the auger. A sign-off form is supplied on the inside front cover to record your safety reviews.

Thank you.



<b>Serial Number:</b>	
Serial number is on the right, at the top of the lower tube.	



## 2. Safety First



The Safety Alert symbol to the left identifies important safety messages on the product and in the manual. When you see this symbol, be alert to the possibility of personal injury or death. Follow the instructions in the safety messages. Why is SAFETY important to you?

Three big reasons:

- Accidents disable and kill.
- Accidents cost.
- Accidents can be avoided.

### SIGNAL WORDS

Note the use of the signal words **DANGER**, **WARNING**, **CAUTION**, and **NOTICE** with the safety messages. The appropriate signal word for each message has been selected using the definitions below as a guideline.

The Safety Alert symbol means ATTENTION, BE ALERT!, YOUR SAFETY IS INVOLVED.

#### DANGER



Indicates an imminently hazardous situation that, if not avoided, will result in serious injury or death.

#### WARNING



Indicates a hazardous situation that, if not avoided, could result in serious injury or death.

#### CAUTION



Indicates a hazardous situation that, if not avoided, may result in minor or moderate injury.

#### NOTICE

Indicates a potentially hazardous situation that, if not avoided, may result in property damage.

## 2.1. GENERAL SAFETY

**Important:** *The general safety section includes instructions that apply to all safety practices. Any instructions specific to a certain safety practice (e.g., assembly safety), can be found in the appropriate section. Always read the complete instructional sections and not just these safety summaries before doing anything with the equipment.*

**YOU** are responsible for the **SAFE** use and maintenance of your equipment. **YOU** must ensure that you and anyone else who is going to work around the equipment understands all procedures and related **SAFETY** information contained in this manual.

Remember, **YOU** are the key to safety. Good safety practices not only protect you, but also the people around you. Make these practices a working part of your safety program.

- It is the equipment owner and the operator's responsibility to read and understand **ALL** safety instructions, safety decals, and manuals and follow them before assembling, operating, or maintaining the equipment. All accidents can be avoided.
- Equipment owners must give instructions and review the information initially and annually with all personnel before allowing them to operate this product. Untrained users/operators expose themselves and bystanders to possible serious injury or death.
- Use this equipment for its intended purposes only.
- Do not modify the equipment in any way. Unauthorized modification may impair the function and/or safety, and could affect the life of the equipment. Any modification to the equipment voids the warranty.
- Do not allow children, spectators, or bystanders within the work area.
- Have a first-aid kit available for use should the need arise, and know how to use it.
- Provide a fire extinguisher for use in case of an accident. Store in a highly visible place.
- Wear appropriate protective gear. This list includes, but is not limited to:
  - a hard hat
  - gloves
  - protective shoes with slip-resistant soles
  - protective goggles
  - hearing protection
- For Powered Equipment: before servicing, adjusting, or repairing powered equipment, unplug, place all controls in neutral or off position, stop the engine or motor, remove ignition key or lock out power source, and wait for all moving parts to stop.



- Follow good shop practices:
  - keep service area clean and dry
  - be sure electrical outlets and tools are properly grounded
  - use adequate light for the job at hand
  - Think SAFETY! Work SAFELY!



## 2.2. ASSEMBLY SAFETY

- Read through the instructions to get to know the sub-assemblies and hardware that make up the equipment.
- Do not take chances with safety. The components are large, heavy, and can be hard to handle. Always use the proper tools, stands, jacks, and hoists for the job.
- Always have 2 or more people assembling the equipment. Because of the weight, do not attempt assembly alone.

## 2.3. TRANSPORT & PLACEMENT SAFETY

- Transport auger in full down position with slight tension on cable.
- Properly place hitch pin and securely attach safety chain. Use a type of hitch pin that will not allow auger to separate from towing vehicle.
- Always attach an SMV (slow moving vehicle) sign before transporting auger. Equip the auger with the necessary lights for transportation where required by law. Always use hazard warning flashers on the tractor/towing vehicle when transporting unless prohibited by law.
- Always travel at a safe speed, never exceeding 15 mph (24 km/hr). Reduce speed on rough surfaces and be cautious when turning corners or meeting traffic.
- Before raising/lowering/moving the auger, make sure the area around the auger is clear of obstructions and/or untrained personnel. Never allow anyone to stand on or beneath auger while transporting or placing auger.
- Do not transport auger on slopes greater than 20°.
- Wheels must be free to move when raising or lowering auger.
- Never attempt to move auger manually. To do so will result in serious injury.

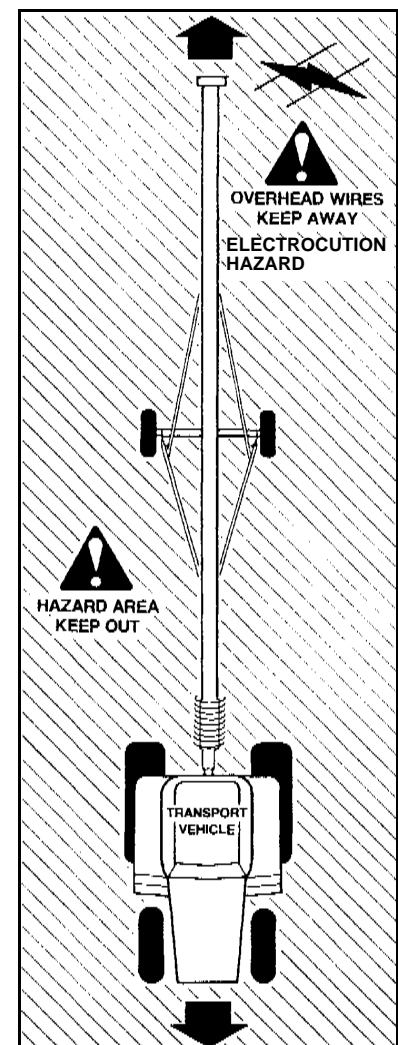

- Before moving auger, check for overhead obstructions and/or electrical wires. Electrocutation can occur without direct contact.
- ➔ **PTO models only:** Disconnect PTO driveline from tractor before moving auger or tractor and secure in transport saddle (where applicable).
- If the track shoe becomes stuck when lowering the auger, continuing to turn the winch handle counter-clockwise will disengage the brake mechanism and create an unsafe condition. Too much slack in the cable may also cause the auger to drop suddenly.
  - The winch must make a clicking sound when raising auger. If clicking sound stops, retain grip on handle, lower auger fully, and repair winch.
  - After lowering auger, turn handle clockwise two clicks to lock winch brake.
  - Always keep a minimum of 3 cable wraps on the winch drum.
  - The winch is designed for manual operation only.

## 2.4. OPERATION SAFETY

---

- Have another trained person nearby who can shut down the auger in case of accident. Always work with a second trained person around augers.
- Do not operate with any of the safety guards removed.
- Keep body, hair, and clothing away from moving parts. Stay away from intake during operation.
- Inspect lift cable before using auger. Replace if frayed or damaged. Make sure it is seated properly in cable sheaves and cable clamps are secure.
- Operate auger on level ground free of debris. If ground is uneven, anchor the auger to prevent tipping or upending.
- Augers are not insulated. Keep away from electrical lines. Electrocutation can occur without direct contact.
- Support the discharge end and/or anchor the intake end before operating to prevent upending.
- Do not use auger as a hoist.
- Empty auger before raising or lowering.
- Lower auger at completion of operation or when not in use. Auger could drop rapidly in case of cable break or hydraulic failure (where applicable).
- Inspect the drive belt(s) before using auger. Replace if frayed or damaged.
- Lock winch before operating auger.
- Do not grab or touch drive belt(s) during operation for any reason.

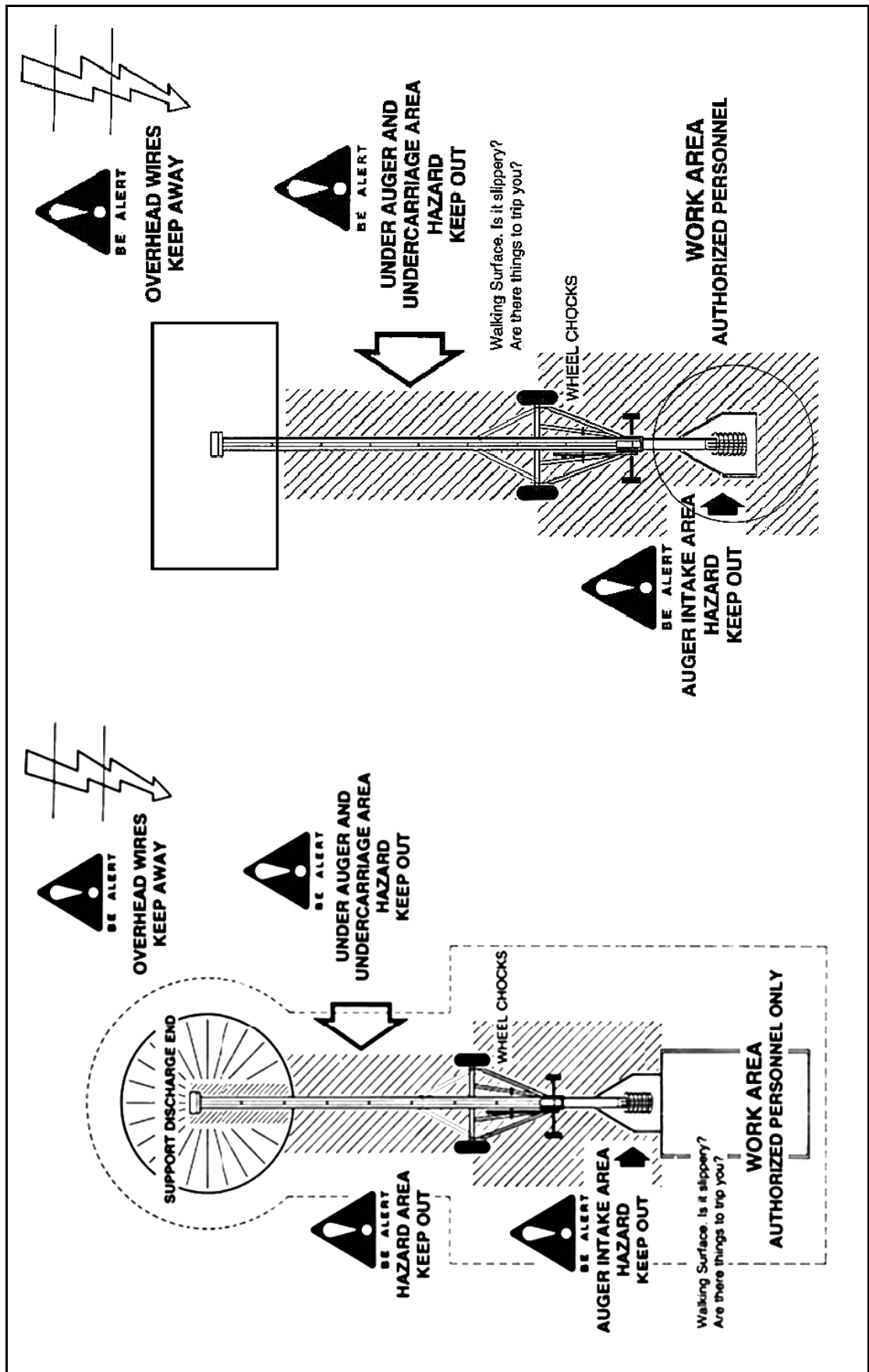

Figure 2.1 Auger Hazard Areas

## 2.5. PTO SAFETY

---

- Never use a PTO driveline without a rotating shield in good working order.
- Ensure PTO driveline is securely attached at both ends before operating.
- Before starting tractor, turn power to PTO to the off position (where applicable).
- Keep body, hair, and clothing away from rotating PTO driveline.
- Ensure the PTO driveline shields turn freely on the PTO driveline.
- Do not exceed operating speed of 540 rpm.
- Keep u-joint angles small and equal. Do not exceed recommended operating length for PTO driveline.

## 2.6. GAS ENGINE SAFETY

---

- Read and understand the operating and maintenance instructions that came with the gas engine.

## 2.7. ELECTRIC MOTOR SAFETY

---

- Inspect the drive belts before using auger. Replace if frayed or damaged.
- Do not grab or touch drive belts during operation for any reason.
- Remember to ground electric motor before using auger.

## 2.8. BATTERY SAFETY

---

- Wear safety glasses when working near batteries.
- Make certain the battery or terminal covers are in place and in good working order.
- Keep all sparks and flames away from batteries; gas given off by electrolyte is explosive.
- Avoid contact with battery electrolyte. Wash off any spilled electrolyte immediately.
- Do not tip batteries more than 45° to avoid electrolyte loss.
- To avoid injury from sparks or short circuits, disconnect battery ground cable before servicing any part of an electrical system.

## 2.9. MAINTENANCE SAFETY

---

- Shut down and lock out all power before attempting maintenance of any kind. **If applicable**, disconnect PTO driveline from tractor.
- After maintenance is complete, replace and secure all safety guards and safety devices, and if applicable, service doors and cleanout covers.
- Support auger tube before attempting maintenance on the undercarriage assembly. Auger should be in full down position for maintenance.

- Use only genuine Westfield replacement parts or equivalent. Replacement parts such as intake guards, pulley guards, PTO driveline shields, winches, and lift cables must meet ASABE standards or serious injury may result. Use of unauthorized parts will void warranty. If in doubt, contact Westfield or your Westfield dealer.
- Do not modify any auger components without authorization from Westfield. Modification can be dangerous and result in serious injuries.

## 2.10. SAFETY DECAL LOCATIONS

---

- Keep safety decals clean and legible at all times.
- Replace safety decals that are missing or have become illegible. See decal location figures below.
- Replaced parts must display the same decal(s) as the original part.
- Safety decals are available from your distributor, dealer, or factory.

### 2.10.1. DECAL INSTALLATION

---

1. Decal area must be clean and dry, with a temperature above 50°F (10°C).
2. Decide on the exact position before you remove the backing paper.
3. Align the decal over the specified area and carefully press the small portion with the exposed sticky backing in place.
4. Slowly peel back the remaining paper and carefully smooth the remaining portion of the decal in place.
5. Small air pockets can be pierced with a pin and smoothed out using the sign backing paper.

### 2.10.2. DECAL LOCATIONS

---

Replicas of the safety decals that are attached to the equipment are shown in this section. Good safety requires that you familiarize yourself with the various safety decals and the areas or particular functions that the decals apply to as well as the safety precautions that must be taken to avoid serious, injury, death, or damage.

*\* Westfield reserves the right to update safety decals without notice. Safety decals may not be exactly as shown.*

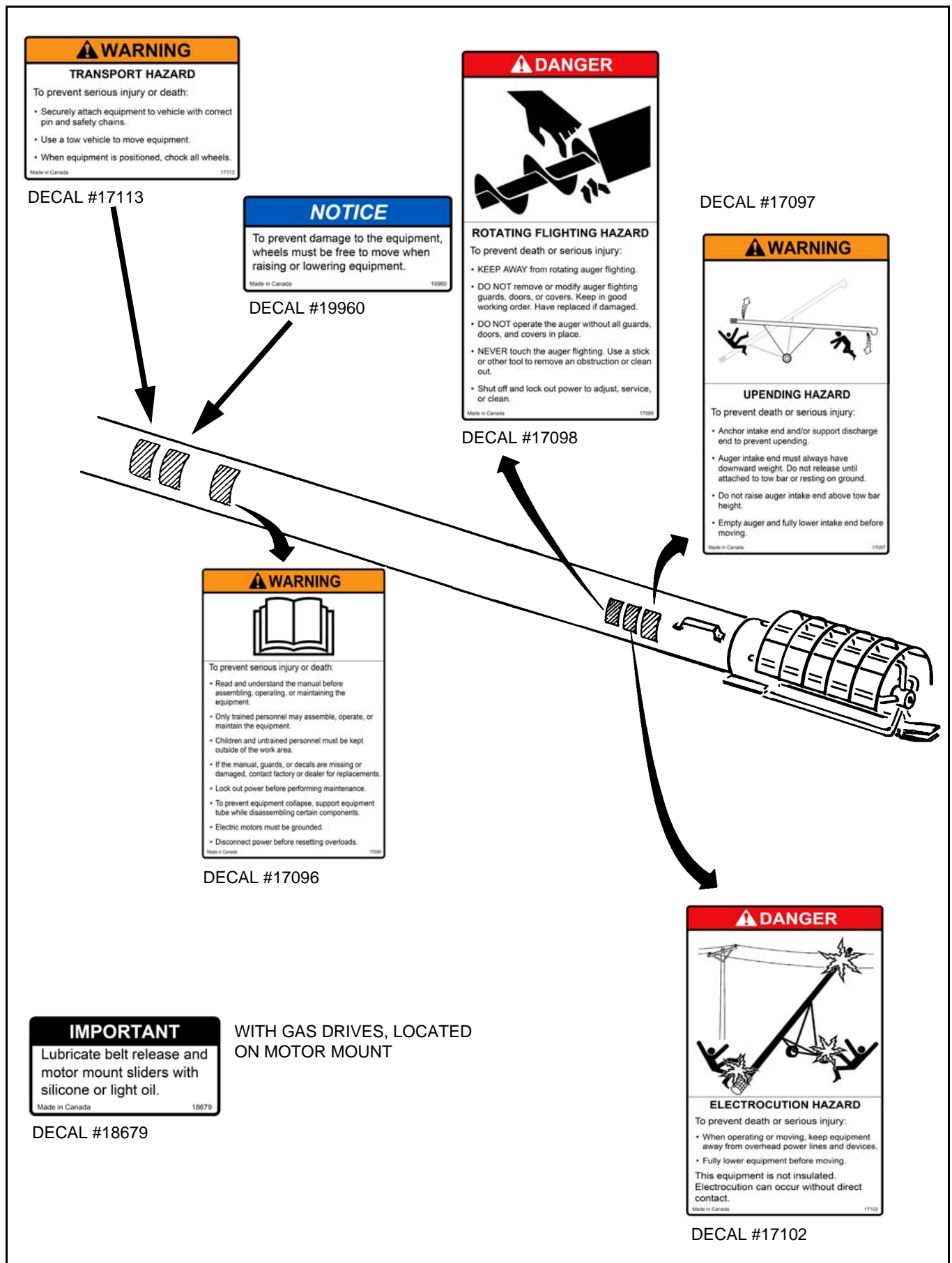

Figure 2.2 Auger Intake Tube Safety Decals

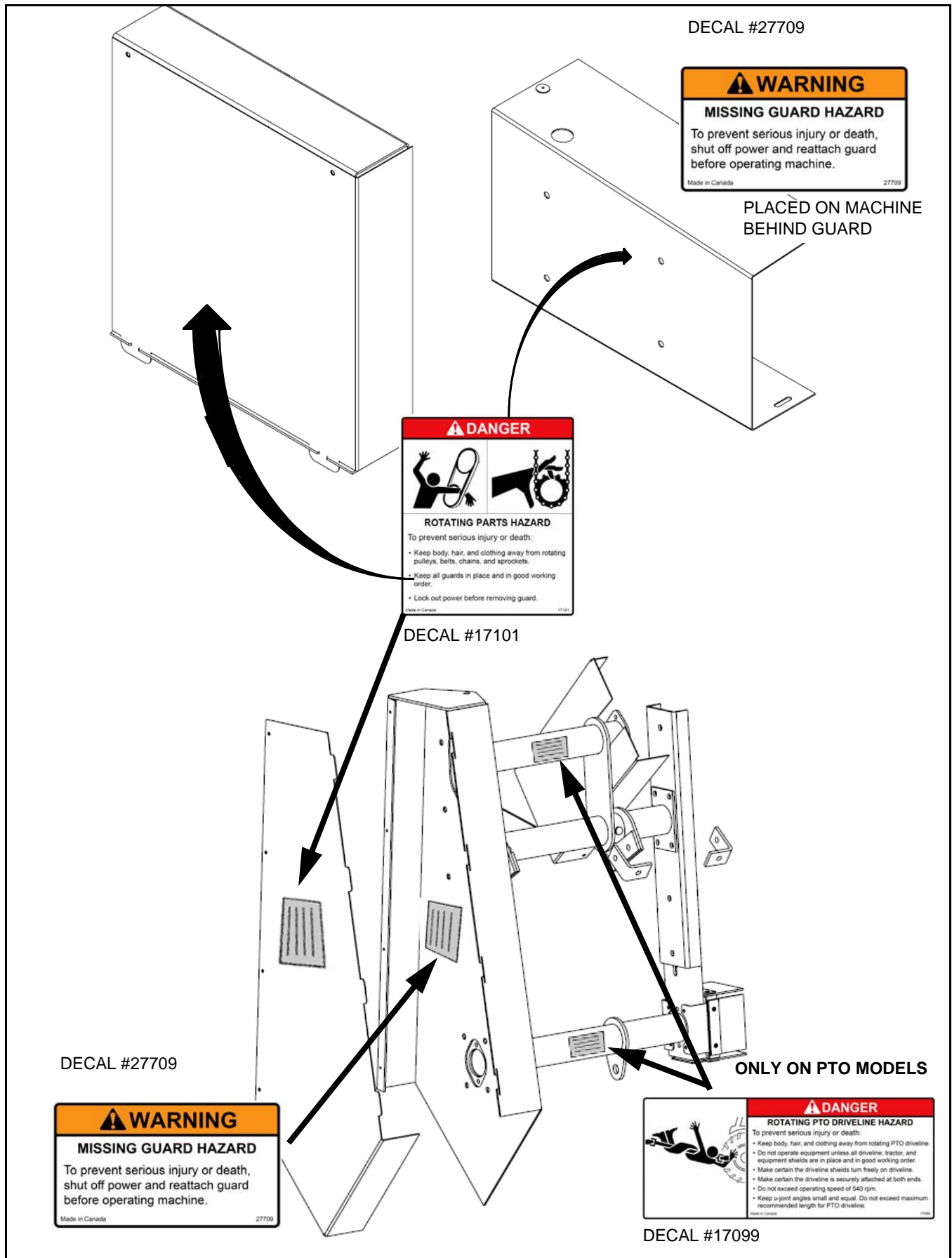

Figure 2.3 V-Belt Guard and PTO Shield Safety Decals

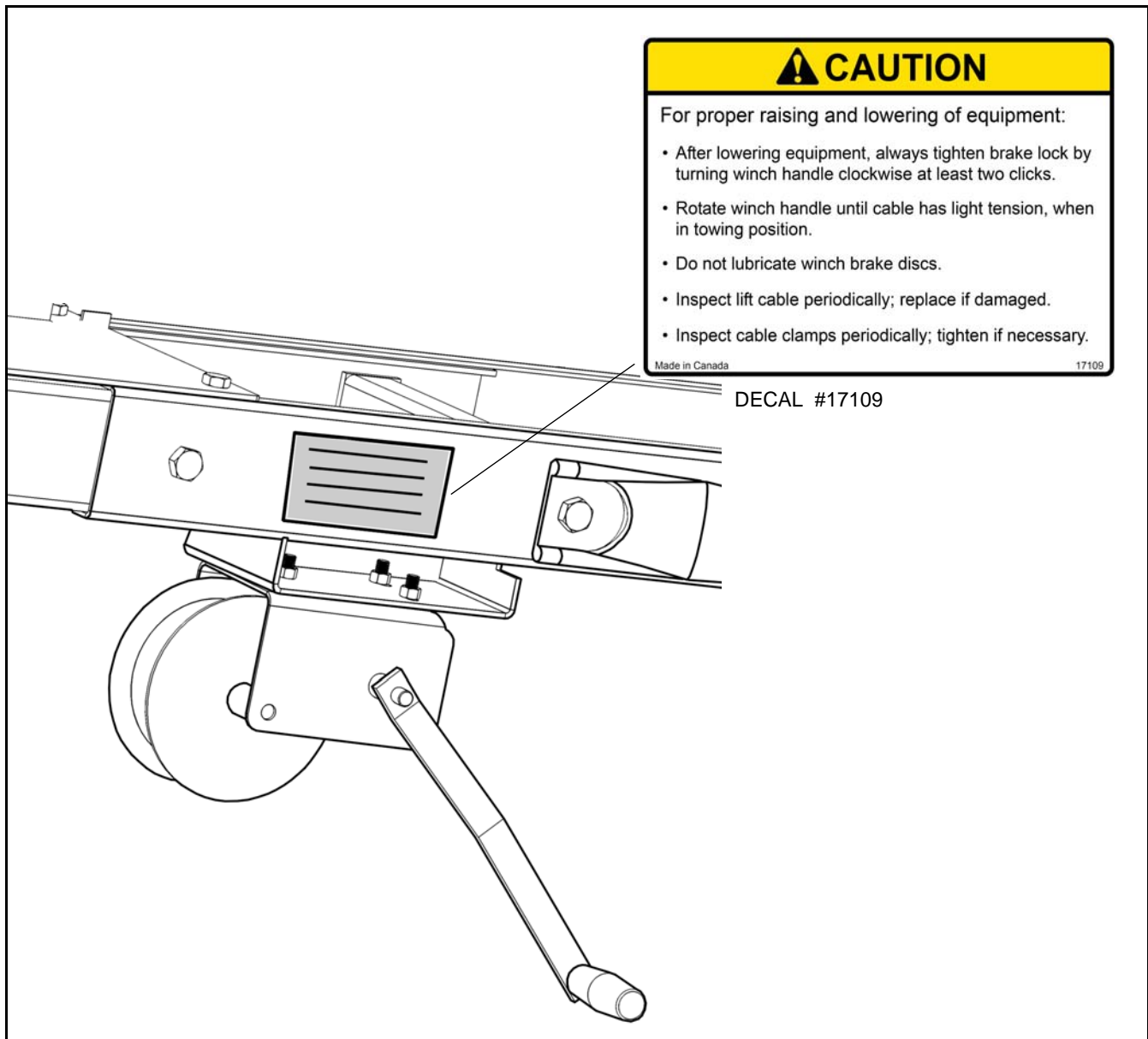

Figure 2.4 Winch Safety Decal

# 4. Transport & Placement

**Warning:** Before continuing, please reread the safety information relevant to this section in the safety section of this manual. Failure to follow the safety instructions can result in serious injury, death, or property damage.

## 4.1. TRANSPORT PROCEDURE

Follow all safety precautions when transporting the auger and use a proper towing vehicle.

1. If auger is raised, place in full down position. The roller track shoe should be seated against the upper track stop with slight tension on the lift cable. Refer to “Lowering & Completion” on page 52.

**Important:** *The winch must have a minimum of 3 wraps of cable on drum when auger is in transport position.*

2. Lock winch: turn handle clockwise until 2 clicks are heard.
3. Place and secure hitch pin and safety chain. Thread safety chain through handle on the lower tube and wrapped around auger tube before attaching to the towing vehicle (Figure 4.1).

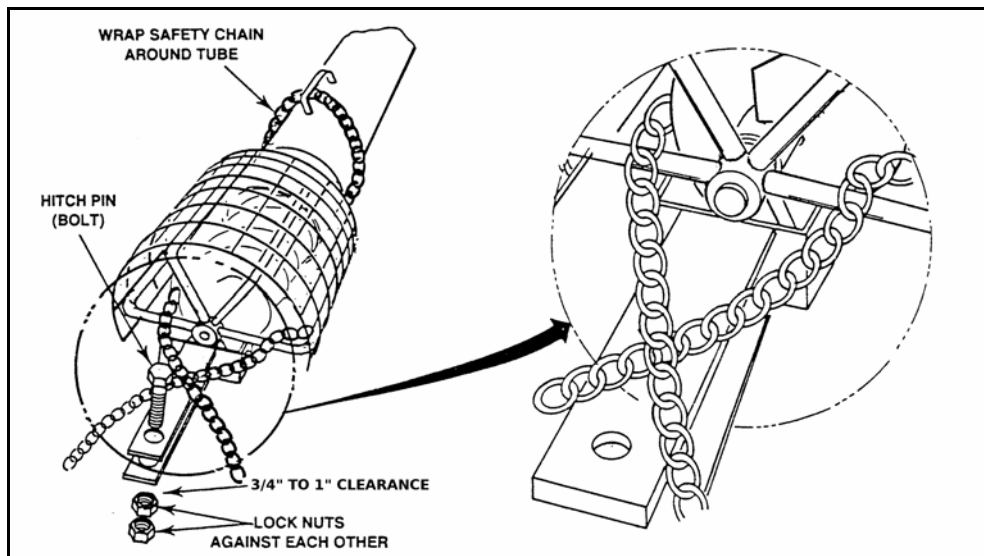

**Figure 4.1**

**Important:** *Use a type of hitch pin (see Figure 4.1) that will not allow auger to separate from towing vehicle.*

### WARNING



If auger wheels are partially or fully buried in snow or grain, failure to clear area around the wheels before moving may cause damage to the auger or result in serious injury.

4. Place belt(s) under tension for transport. Refer to “Gas / Electric Motor Mount Installation” on page 32 for more information.
- ➔ 5. **PTO models only:** Disconnect PTO driveline from tractor and secure in transport saddle.
6. Beware of overhead obstructions and electrical wires and devices. These augers have minimum clearances from 10'–13' (3.05 m–3.96 m) in normal transport position.
7. Refer to “Transport & Placement Safety” on page 11 for important safety information before towing.

## 4.2. PLACEMENT PROCEDURE

---

1. Ensure towing hitch is in place and secure.

**Important:** *Use a type of hitch pin (see Figure 4.1) that will not allow auger to separate from towing vehicle.*

2. Before raising or positioning auger, make sure that entire area in line of travel, both on the ground and overhead, is clear of any obstructions or electrical wires.

WARNING	
	If auger wheels are partially or fully buried in snow or grain, failure to clear the area around the wheels before moving may cause damage to the auger or result in serious injury.

3. Place auger on reasonably level ground when raising, lowering, or positioning.

**Note:** *Make certain cable is properly seated in cable groove before raising auger. Refer to Figure 3.14 on page 23.*

4. To raise auger, turn winch handle clockwise. Use a firm grip on winch handle; do not release unless the ratchet pawl is fully engaged.

NOTICE
Do not turn winch handle counter-clockwise except when lowering auger, or severe damage will occur.

**Important:** *Winch must make clicking sound when raising auger. If clicking stops, retain grip on handle, lower auger fully, and repair ratchet.*

5. Move the auger into working position slowly. Do not unhitch and attempt to move auger by hand.

WARNING	
	Never attempt to increase height of auger by positioning wheels on lumber, blocks, or by any other means. To do so will result in damage to equipment and/or personal injury.

6. Once auger is in position, chock wheels on both sides and apply the park brake on the tractor (or chock its wheels as well) to prevent movement during operation.

**Important:** *When releasing auger from the towing vehicle, test the intake end for downward weight. Do not raise the intake end above drawbar height. When the intake end is elevated too high with auger in raised position, the balance of weight quickly transfers to the discharge end, causing it to upend. Ensure proper anchoring/support.*

**Important:** **PTO models only:** The PTO driveline is a non-separable type. Remove from tractor and secure in the transport saddle on auger before moving tractor away from auger.

7. When operating auger in the raised position, rest the discharge end lightly on the bin roof, or tie to bin to prevent wind from toppling auger. When operating the auger in a freestanding position, anchor the intake end.
8. Anchor and/or support auger during operation.
  - When lower half of auger empties of grain, the weight balance transfers to upper end of auger, which can cause upending.

WARNING	
	Do not use auger as a hoist to raise any object regardless of weight. This will create an unsafe condition and will void warranty.

9. Refer to "Lowering & Completion" on page 52 for correct lowering procedure.



# 5. Operation

**Warning:** Before continuing, please reread the safety information relevant to this section in the safety section of this manual. Failure to follow the safety instructions can result in serious injury, death, or property damage.

## 5.1. PRE-OPERATIONAL CHECKLIST

Before operating auger each time, the operator must confirm the following:

- All fasteners are secure as per assembly instructions.
- PTO driveline is connected and secure (where applicable).
- PTO driveline shield rotates freely (where applicable).
- Drive belt(s) are not frayed or damaged.
- Drive belt(s) are properly adjusted and aligned.
- Lift cable is not frayed or damaged.
- Lift cable is properly seated in cable sheaves.
- Cable clamps are secure.
- Tube alignment is reasonably straight.
- Auger wheels are chocked, and if necessary, tractor wheels are chocked or the parking brake has been engaged.
- Intake area and discharge spout are free of obstructions.
- Proper maintenance has been performed.

## 5.2. AUGER DRIVE & LOCKOUT PROCEDURE

Drive Type	Before Operation	Lockout
Electric Motor	<p>Before starting motor, ensure</p> <ul style="list-style-type: none"> <li>• motor is properly grounded</li> <li>• belt release lever is disengaged so that the belt(s) are released from lower motor pulley</li> <li>• pulley guards are in place and secure</li> </ul>	<p>The electric motor should be equipped with a main power disconnect switch capable of being locked in the off-position only. The switch should be in the locked position during shutdown or whenever maintenance is performed on the auger.</p> <ul style="list-style-type: none"> <li>• If reset is required, disconnect all power <b>before</b> resetting motor.</li> </ul>

Drive Type	Before Operation	Lockout
Gas Engine	<p>Before starting engine, ensure</p> <ul style="list-style-type: none"> <li>• gas tank is properly closed</li> <li>• belt release lever is disengaged so that the belt(s) are released from lower motor pulley</li> <li>• area surrounding auger is properly ventilated</li> <li>• pulley guards are in place and secure</li> </ul>	<p>Shut down and lock out power source.</p> <ol style="list-style-type: none"> <li>For engines with a rope or crank start, remove the spark plug wire or the spark plug.</li> <li>For engines with an electric start, remove the ignition key, the spark plug wire, or the spark plug.</li> </ol>
PTO Driveline	<p>Before starting, ensure</p> <ul style="list-style-type: none"> <li>• PTO driveline is securely attached to the tractor and jack-haft</li> <li>• tractor park brake is engaged and/or wheels are chocked</li> <li>• you are not exceeding the maximum operating length of 64" (1610 mm) of the PTO driveline or maximum angle of 15°</li> <li>• PTO drive on the tractor is in the off position</li> </ul>	<p>Shut off tractor's engine and remove key from tractor.</p> <ul style="list-style-type: none"> <li>• If removing key is impossible, remove PTO driveline from tractor.</li> </ul>

## 5.3. OPERATING PROCEDURE

### 5.3.1. START-UP & BREAK-IN

#### BREAK-IN

1. Complete the pre-operational checklist at the beginning of this chapter. If everything is satisfactory, prepare for a 30-minute operation at half speed (PTO and gas models).
2. Correctly position portable grain hopper secure it to the auger with both straps (where applicable).

**Important:** *Anchor and/or support auger during operation. When lower half of auger empties of grain, the weight balance transfers to the upper end of auger, which can cause upending.*

<b>CAUTION</b>	
	<p>Do not start auger until area is clear of all unauthorized personnel.</p> <p>Do not exceed 540 rpm on the PTO.</p>

3. Start tractor and engage PTO driveline or start electric motor or gas engine if applicable, then feed grain to auger. If auger functions normally, check at varying speeds for a period of 30 minutes (PTO and gas models).

**Important:** *When starting auger for the first time, be prepared for an emergency shutdown in case of excessive vibration or noise. Note that auger may run rough until tube is polished.*

4. Upon completion of initial run, shut down auger. See “Shutdown” on page 52. for more information on shutting down your auger.
5. Lock out power source and conduct a complete inspection of auger following the checklist at the beginning of this chapter.

After the initial start-up and inspection, the auger should be shut down and inspected at least three times during the first 10 hours of operation.

Keep operation of empty auger to a minimum, as this results in excessive wear.

Once auger is broken in, the checklist should be a part of the daily routine before operating auger.

### 5.3.2. OPERATING WITH A FULL LOAD

---

1. When operating the auger, always work with a second person in a position to monitor the operation and initiate a shutdown in case of emergency.
2. Monitor the auger during operation for abnormal noises or vibrations.
3. Shut off all power before making adjustments, servicing, or clearing the machine.

<b>DANGER</b>	
	<p>Rotating Flighting Hazard!</p> <p>To prevent death or serious injury:</p> <ul style="list-style-type: none"><li>• Keep away from rotating auger flighting.</li><li>• Do not remove or modify auger flighting guards, doors, or covers. Keep in good working order. Have replaced if damaged.</li><li>• Do not operate the auger without all guards, doors, and covers in place.</li><li>• Never touch the auger flighting. Use a stick or other tool to remove an obstruction or clean out.</li><li>• Shut off and lock out power to adjust, service, or clean.</li></ul>

### 5.3.3. SHUTDOWN

---

#### NORMAL SHUTDOWN

1. Near the end of a load, reduce the feed of grain and decrease auger speed (when possible) until auger is clear of all grain.
2. Disengage belt release and stop engine / motor, or disengage PTO.
3. Shut down and lock out power source.

**Important:** *The flighting rpm on augers equipped with electric motors is not adjustable. To clear auger of grain, decrease the grain flow until auger is clear and stop motor.*

#### EMERGENCY SHUTDOWN / FULL-TUBE RESTART:

1. If the auger is shut down for an emergency, lock out motor (gas / electric) or tractor (PTO models) before correcting the problem.
  - If the problem is plugging, clear as much of the grain as possible using a piece of wood, wet/dry vac, or other tool before restarting auger. **Do not reach in and use your hands** (see “Auger Drive & Lockout Procedure” on page 49 for lockout procedure.)
2. If auger is full of grain, do not restart at full speed. Engage the belt release gradually until normal operating speed is reached.

#### NOTICE

Starting the auger under load may result in damage to unit.  
Be sure there is no blockage.

### 5.3.4. LOWERING & COMPLETION

---

At the completion of an operation, the auger should be moved to the next work area or to a storage area. After operation:

1. Clean entire work area.
2. Remove all supports and chocks.
3. Move auger out of working position and lower fully (see shaded box that follows for lowering procedure).
4. Move auger to the next work area or to a storage area and then clean out.

### LOWERING

1. For PTO drives: disconnect driveline from tractor before lowering.
2. Ensure area beneath auger is clear.
3. Turn winch counterclockwise to lower (there will be no clicking sound when lowering).
4. After lowering, turn handle clockwise until you hear 2 clicks to lock brake.
  - Use a firm grip on handle. Do not release unless ratchet pawl is fully engaged.
  - The winch is designed for manual operation only.
  - When lowering, never continue to turn handle counterclockwise if the cable does not keep moving out under load. This will disengage the brake mechanism and create an unsafe condition. If this happens, winch in slack cable and correct problem.

Do not leave auger in raised position when not in use. Auger could drop rapidly due to a cable break. High winds may also upset auger.

5. Clean out auger.
  - a. Shut off tractor engine (PTO models) or shut off motor (gas / electric) and lock out power.
  - b. Manually clean out grain with a piece of wood, vacuum cleaner, or other tool. Do not use hands.
6. Prepare for transport and placement or storage (see “Transport & Placement” on page 45 or “Maintenance & Storage” on page 55 for more information).

## 5.4. HORSEPOWER REQUIREMENTS

Table 5.1 <sup>a</sup>

	8"		10"	
	Gas	Electric	Gas	Electric
31'	16	5	20	7.5-10
36'	16	5-7.5	20-25	10
41'	16	5-7.5	20-25	10-15
46'	18	7.5	—	—
51'	18	7.5	—	—

a. With dry grain. High moisture grain will require more horsepower.



# 6. Maintenance & Storage

**Warning:** Before continuing, please reread the safety information relevant to this section in the safety section of this manual. Failure to follow the safety instructions can result in serious injury, death, or property damage.

Proper maintenance habits on the TFX auger mean a longer life, better efficiency, and safer operation. Please follow the guidelines below.

## 6.1. GENERAL MAINTENANCE PROCEDURES

Area	Maintenance Procedure	Frequency
General	While auger is in use, observe the checklist on page 49.	Daily
General	Check all operating, lifting, and transport components. Replace damaged or worn parts before using auger. For replacement instructions, see Chapter 3.	Regularly
Lift Cable	Check and replace if frayed or damaged. Make sure cable clamps are secure.	Periodically
Wheel Hubs	Repack with lithium-based grease.	Every 2–3 years
Tire Pressure	Check with a pressure gauge. Pressure should be maintained according to side wall recommendations.	Monthly, or if it seems low
Upper Chain Drive	Fill enclosed upper drive housing with grease. TFX 831, 836, 841, 846, 851: 750 g / 26 oz TFX 1031, 1036, 1041: 1100g / 40 oz  For continuous use in extreme cold, semi-fluid arctic grease or heavy oil may be used.	Regularly
Drive Chain Adjustment	Maintain 1/4" - 1/2" chain deflection. To adjust, loosen bolts on top bearing in the upper drive housing, adjust chain to proper tension, and re-tighten bolts.	Regularly
Belt Release and Motor Mount Sliders	Lubricate with silicone or light oil.	Regularly
Intake Bushing	Grease.	Daily
Truss Cables	Adjust to keep auger tube reasonably straight (if equipped).	As necessary
Belt Release	Keep film of silicone lubricant on motor mount pipes and sliding end of push bar for easier release of belt tension.	Often
Cable Pulleys	Oil.	As needed.

Area	Maintenance Procedure	Frequency
Winch  Note: Service winch with auger in fully lowered position and cable slack.	Keep a film of grease on gears.	Regularly
	Oil the bushings, drum shaft, and ratchet. Take care not to get oil or grease on brake discs. Service winch with auger in fully lowered position and cable slack.	Occasionally
	Replace brake discs if less than 1/16" thick.	As required
	Check for proper ratchet pawl operation. When cranking in (clockwise) = loud clicking When cranking out (counterclockwise) = no clicking and ratchet pawl fully engaged into gear teeth	Regularly
PTO Driveline	Check shield and replace if damaged.	Regularly
	Lubricate both universal joints.	After every 8 hours of operation.
	Lubricate the center portion of driveline (grease fitting is beneath shield) where applicable.	Yearly
Gearbox	Maintain oil level at half full (center of cross shaft) with EP90 lube oil. Gearbox should be level when checking or refilling. Do not overfill.	Regularly
Drive Belts	Check and replace if frayed or damaged.	Regularly
	Ensure tension is correct under load. Correct operating tension is the lowest tension at which the belts will not slip under peak load conditions.	Regularly

**To replace drive shaft bearings:** remove flange bolts, split one-piece wood bearing with chisel, then replace with new two-piece wood bearing and replace flanges.

**TO CHANGE BELTS:**

First, shut off and lock out all power!	Gas Engine Drive	Electric and PTO Drive
<b>Lower Belts (jackshaft to engine, motor, or PTO)</b>	1. Remove jackshaft pulley guard.	1. Remove jackshaft pulley guard.
	2. Remove engine pulley guard if necessary.	2. Remove motor/PTO pulley guard.
	3. Disengage belt tensioner handle on belt tension tube to loosen belts.	3. Unlock nut and loosen tensioner bolt on motor/PTO mount base.
	4. Remove old belts and replace.	4. Remove old belts and replace.
	5. Engage belt tensioner handle to tighten belts.	5. Tighten tensioner bolt on motor mount base and turn nut to lock in place.
	6. Replace guards.	6. Replace guards.

**TO CHANGE BELTS:**

First, shut off and lock out all power!	Gas Engine Drive	Electric and PTO Drive
<b>Upper Belts (jackshaft to gearbox)</b>	<b>All Drives</b>	
	1. To change upper belts, the lower belts must be loosened. Disengage belt tensioner or remove bottom belts.	
	2. Remove gearbox pulley guard and jackshaft pulley guard.	
	3. Turn tensioner bolt on jackshaft assembly to loosen belts.	
	4. Loosen 4 bolts on base of jackshaft assembly.	
	5. Remove and replace belts.	
	6. Once belts are installed, slide the jackshaft assembly as far as possible by hand towards the discharge end of the auger. Tighten 4 bolts on base.	
	7. Tighten tensioner bolt to tighten belts. Lock in place with nut.	
	8. Replace pulley guards. 9. Tension lower belts. The belt tensioner may need readjustment, see Section 3.12.	

## 6.2. GENERAL STORAGE PROCEDURES

**TO PROTECT AUGER IN STORAGE DURING THE OFF SEASON:**

1. Lower the auger to the full down position with a slight tension on cable.
2. Lubricate all grease fittings per maintenance procedures.
3. Inspect auger for damage and note any repairs required. Order replacement parts from your dealer.
4. Check tire pressure and inflate if necessary. See tire side-wall for pressure recommendations.
- ➔ 5. Where applicable:
  - a. Remove battery and store in a cool, dry place. Recharge periodically as required.
  - b. Drain gas tank.
  - c. Cover engine/motor with plastic to protect from weather.
6. Clean and re-lubricate spline on PTO driveline. Cover PTO driveline with plastic bag to protect it from the weather and place in the transport saddle.
7. Tow auger to storage area. Park and chock wheels.

<b>CAUTION</b>	
	Support discharge end of auger before removing or replacing any parts on the undercarriage.

### TO PREPARE AUGER FOR USE AFTER STORAGE:

1. Check tire pressure and inflate if necessary. See tire side-wall for pressure recommendations.
2. Tow auger to worksite.
- ➔ 3. Where applicable:
  - a. Remove protective covering from motor.
  - b. Remove cover from spline of PTO driveline and re-lubricate.
  - c. Replace battery in holder (where applicable). When recharging battery, follow the correct procedure as indicated in the battery manual.
4. Check oil level in gearbox and refill if necessary (half full only). **Do not overfill.**
5. On augers equipped with lubricated upper drive, check level of lubrication annually and add as needed. Refill to plug level.
6. Replace any damaged parts.
7. Conduct general maintenance procedures before using auger.

**Note:** *Use only genuine Westfield replacement parts or equivalent. Replacement parts such as intake guards, pulley guards, PTO driveline shields, winches and lift cables Must meet ASAE standards or serious injury may result. Use of unauthorized parts will void warranty. If in doubt, contact Westfield or your Westfield dealer. Do not modify any auger components.*

# 7. Troubleshooting

Problem	Possible Cause	Remedy
<p><b>Excessive noise or vibration.</b></p> <p>*Remember to follow proper break-in procedures—auger may run rough until tube is polished. If noise is extreme from outset or continuous after several loads of grade are fed, continue with troubleshooting below</p>	Chatter from wooden bearings.	Spray penetrating lubricant between shaft and bearing surface. Bearings will break in over time. *If replacement of a bearing becomes necessary, split bearings are available to avoid having to slide all bearings off driveshaft.
	Truss cables incorrectly adjusted.	Support end of auger and adjust cables so auger is flat or curves slightly upwards.
	Flighting peeled back due to plugging.	Inspect spout end of auger for flight condition. Remove and replace flight sections as necessary.
	Top drive inadequately lubricated.	Fill to appropriate level with grease. Top drive is not designed to be filled with oil.
	Bent flighting sections.	Support auger and remove all flight sections. Check for straightness of flight stubs by rolling across flat concrete section. Straighten stub or replace as necessary. Take care not to bend flighting when reinstalling.
	Obstruction in tube.	Visually inspect for cloth or trash wrapped around flighting, or buildup of gum from oily crops such as flax or canola.
<p><b>Drive belts jumping off pulleys.</b></p>	Motor misaligned.	Ensure drive and driven pulleys are correctly aligned.
	Belts mismatched.	Check manual for correct belt sizes and only replace in pairs.
	Belt tension inadequate.	Maintain correct tension as per Assembly section.
	Using a lower horsepower motor than recommended.	See manual for recommended motor sizes.
<p><b>Shear bolts fail repeatedly.</b></p>	Incorrect shear bolt type.	Replace with correct part number. Westfield shear bolts are specifically designed to provide correct driveline protection.
	Shear bolt hole worn out-of-round.	Frequent use of the incorrect shear bolt size can wear the mounting hole creating a “scissor effect,” which will require replacement of the affected parts.
	Corn spreaders in bin unable to keep up with auger output.	Slow down auger or remove corn spreaders.
	Flighting peeled back as a result of plugging.	Occurs when bin has overfilled, or corn spreaders restrict end of discharge. Inspect flighting at discharge end of auger. If necessary, replace flighting.
	Driveline failure (bearing, gear-box, etc.).	See Maintenance section.

Problem	Possible Cause	Remedy
<b>Premature wear on auger tubes.</b>	Auger being run at low capacity or empty for extended period of time.	Frequently occurs on farms using grain wagons. Auger should not be left unattended when filling bins. Depending on application, a belt conveyor may be more appropriate.
	Bent flighting.	
	Flighting allowed to wear beyond normal point of replacement.	When flighting becomes razor-thin at intake, replacement is critical. Since flight material is double thickness at welded lap joints, high spots on flight occur and can accelerate spot tube wear.

# WARRANTY

Westfield Industries Ltd. warrants products of its manufacture against defects in materials or workmanship under normal and reasonable use for a period of one year after date of delivery to the original purchaser.

Our obligation under this warranty is limited to repairing, replacing, or refunding defective part or parts which shall be returned to a distributor or a dealer of our Company, or to our factory, with transportation charges prepaid. This warranty does not obligate Westfield Industries Ltd. to bear the cost of labor in replacing defective parts. Any defects must be reported to the Company before the end of the one year period.

This warranty shall not apply to equipment which has been altered, improperly assembled, improperly maintained, or improperly repaired so as to adversely affect its performance. Westfield Industries Ltd. makes no express warranty of any character with respect to parts not of its manufacture.

The foregoing is in lieu of all other warranties, expressed or implied, including any warranties that extend beyond the description of the product, and the IMPLIED WARRANTY of MERCHANTABILITY is expressly excluded.

WESTFIELD INDUSTRIES LTD.

ROSENORT, MANITOBA

CANADA

ROG 1W0

## ***WESTFIELD***<sup>®</sup>

Westfield Industries is a Division of Ag Growth Industries LP

Part of the Ag Growth International Inc. Group

P.O. Box 39

Rosenort, Manitoba, Canada R0G 1W0

Phone: (866) 467-7207 (Canada & USA)

Fax: (866) 768-4852

website: [www.grainaugers.com](http://www.grainaugers.com)

email: [sales@grainaugers.com](mailto:sales@grainaugers.com)

© Ag Growth Industries Limited Partnership 2010

Printed in Canada