

# WESTFIELD®

## GRAVITY WAGON AUGER

GWA-612 / GWA-615

ASSEMBLY & OPERATION MANUAL

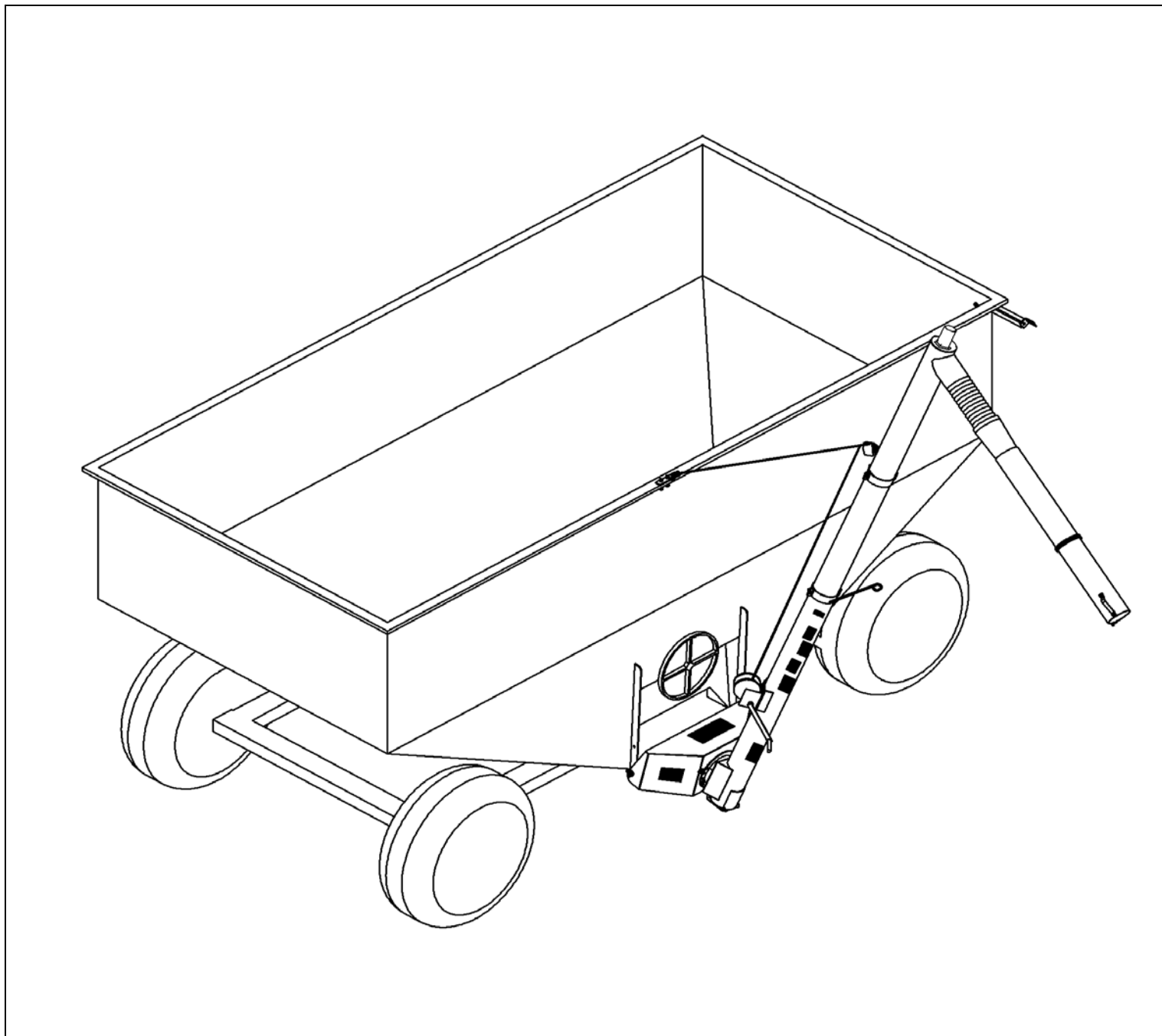

Read this manual before using product. Failure to follow instructions and safety precautions can result in serious injury, death, or property damage. Keep manual for future reference.

Part Number: 30388 R1

Revised: 5/2/10



# TABLE OF CONTENTS

<b>1. Introduction .....</b>	<b>3</b>
<b>2. Safety First.....</b>	<b>5</b>
2.1. General Safety .....	6
2.2. Assembly Safety.....	7
2.3. Operational Safety.....	7
2.4. Transport and Placement Safety .....	8
2.5. Hydraulic Safety .....	8
2.6. Maintenance Safety.....	9
2.7. Safety Decal Locations.....	9
2.7.1. Decal Installation .....	9
2.7.2. Decal Locations .....	10
<b>3. Assembly .....</b>	<b>11</b>
3.1. Gravity Wagon Preparation .....	11
3.2. Discharge Hopper .....	12
3.3. Cable Anchor Bracket .....	12
3.4. Auger Installation.....	13
3.5. Winch and Liftcable Installation .....	13
3.6. Transport Bracket.....	14
3.7. Unload Spout & Solenoid Valve .....	16
3.8. Electrical Hookup .....	17
3.9. Spout Hanger .....	17
<b>4. Operation .....</b>	<b>19</b>
4.1. Pre-Operational Checklist .....	19
4.2. Hydraulic Specifications .....	19
4.3. Start-Up and Break-in.....	20
4.4. Completion / Clean-Up .....	21
4.5. Transport.....	21
<b>5. Maintenance &amp; Storage.....</b>	<b>23</b>
5.1. Maintenance Procedures .....	23
5.2. Storage Procedures .....	23
<b>6. Troubleshooting .....</b>	<b>25</b>
Warranty.....	27



# 1. Introduction

Congratulations. As the new owner of a grain auger, you will be working with equipment designed to complement and improve your farming operation. Before using this auger, please read this manual and all safety labels and familiarize yourself with the various features of the machine and the necessary precautions for efficient and safe operation.

In addition, anyone using this auger is required to comply with all safety precautions in this manual and in safety labels attached to the auger. A sign-off form is supplied on the inside front cover to record your safety reviews.

Thank you.

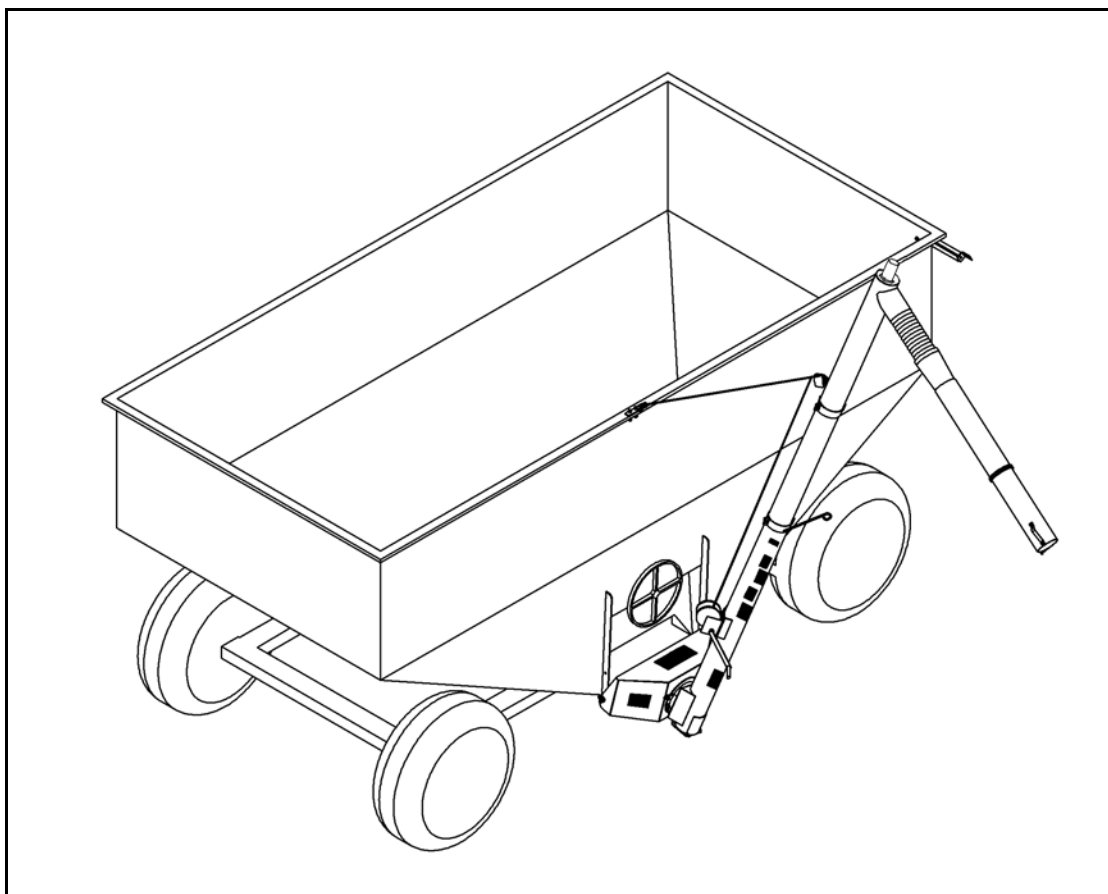

<b>Serial Number:</b>	
*located on the tube	



# 2. Safety First



The Safety Alert symbol to the left identifies important safety messages on the product and in the manual. When you see this symbol, be alert to the possibility of personal injury or death. Follow the instructions in the safety messages. Why is SAFETY important to you?

Three big reasons:

- Accidents disable and kill.
- Accidents cost.
- Accidents can be avoided.

## SIGNAL WORDS

Note the use of the signal words **DANGER**, **WARNING**, **CAUTION**, and **NOTICE** with the safety messages. The appropriate signal word for each message has been selected using the definitions below as a guideline.

The Safety Alert symbol means ATTENTION, BE ALERT!, YOUR SAFETY IS INVOLVED.

### DANGER



Indicates an imminently hazardous situation that, if not avoided, will result in serious injury or death.

### WARNING



Indicates a hazardous situation that, if not avoided, could result in serious injury or death.

### CAUTION



Indicates a hazardous situation that, if not avoided, may result in minor or moderate injury.

### NOTICE

Indicates a potentially hazardous situation that, if not avoided, may result in property damage.

## 2.1. GENERAL SAFETY

**Important:** *The general safety section includes instructions that apply to all safety practices. Any instructions specific to a certain safety practice (e.g., assembly safety), can be found in the appropriate section. Always read the complete instructional sections and not just these safety summaries before doing anything with the equipment.*

**YOU** are responsible for the **SAFE** use and maintenance of your equipment. **YOU** must ensure that you and anyone else who is going to work around the equipment understands all procedures and related **SAFETY** information contained in this manual.

Remember, **YOU** are the key to safety. Good safety practices not only protect you, but also the people around you. Make these practices a working part of your safety program.

- It is the equipment owner and the operator's responsibility to read and understand **ALL** safety instructions, safety decals, and manuals and follow them before assembling, operating, or maintaining the equipment. All accidents can be avoided.
- Equipment owners must give instructions and review the information initially and annually with all personnel before allowing them to operate this product. Untrained users/operators expose themselves and bystanders to possible serious injury or death.
- Use this equipment for its intended purposes only.
- Do not modify the equipment in any way. Unauthorized modification may impair the function and/or safety, and could affect the life of the equipment. Any modification to the equipment voids the warranty.
- Do not allow children, spectators, or bystanders within the work area.
- Have a first-aid kit available for use should the need arise, and know how to use it.
- Provide a fire extinguisher for use in case of an accident. Store in a highly visible place.
- Wear appropriate protective gear. This list includes, but is not limited to:
  - a hard hat
  - gloves
  - protective shoes with slip-resistant soles
  - protective goggles
  - hearing protection
- For Powered Equipment: before servicing, adjusting, or repairing powered equipment, unplug, place all controls in neutral or off position, stop the engine or motor, remove ignition key or lock out power source, and wait for all moving parts to stop.



- Follow good shop practices:
  - keep service area clean and dry
  - be sure electrical outlets and tools are properly grounded
  - use adequate light for the job at hand
  - Think SAFETY! Work SAFELY!



## 2.2. ASSEMBLY SAFETY

- Read through the instructions to get to know the sub-assemblies and hardware that make up the equipment.
- Do not take chances with safety. The components are large, heavy, and can be hard to handle. Always use the proper tools, stands, jacks, and hoists for the job.
- Always have 2 or more people assembling the equipment. Because of the weight, do not attempt assembly alone.

## 2.3. OPERATIONAL SAFETY

- Keep children and untrained personnel away from auger work area (Figure 2.1). The area around the auger is not safe for untrained personnel, and especially not safe for children.
- Have another person nearby who can shut down the auger in case of accident. Always work with a second person around augers.
- Do not operate with any of the safety guards removed or cleanout door open. Ensure cleanout door is latched securely.
- Keep body, hair, and clothing away from moving parts. Stay away from intake during operation.
- Augers are not insulated. Keep away from electrical lines. Electrocutation can occur without direct contact.

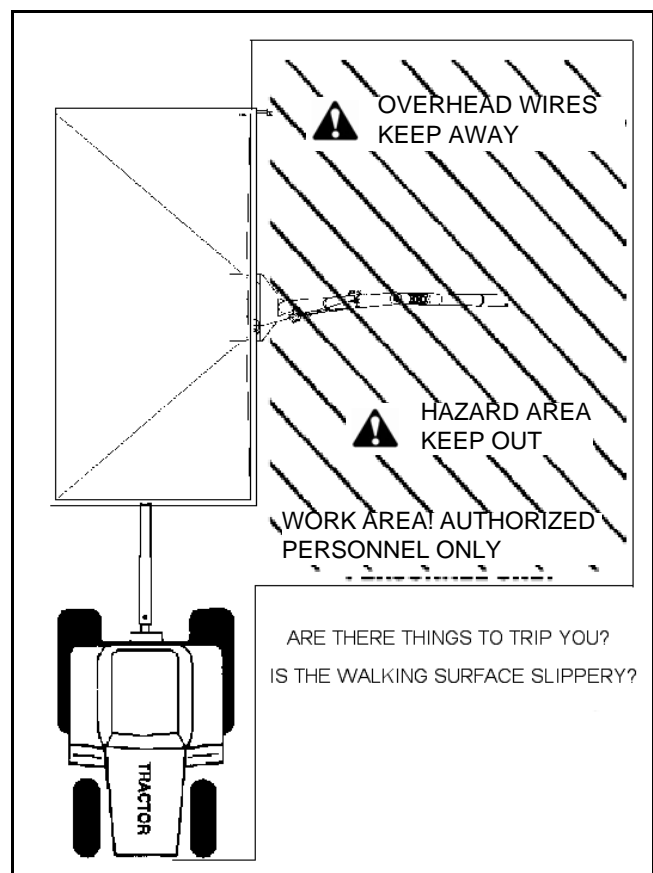

Figure 2.1

- Keep out of gravity wagon at all times.
- Inspect lift cable before using auger. Replace if frayed or damaged. Make sure it is seated properly in the cable pulley and that cable clamps are secure.

- Reposition auger to transport position after completion of operation or when not in use.

## 2.4. TRANSPORT AND PLACEMENT SAFETY

---

- Transport auger in the transport position with auger tube locked into place with retaining pin.
- Always attach an SMV (slow moving vehicle) sign before transporting wagon and auger assembly.
- Before moving auger (and wagon), clear area around the auger of obstructions and/or unauthorized personnel. Never allow anyone to stand on or beneath auger while transporting or placing auger.
- Before moving auger (and wagon), check for overhead obstructions and/or electrical wires. Electrocution can occur without direct contact.
- Use extreme caution when turning and cornering.
- Do not raise or lower auger until hazard area is clear.
- When lowering auger, never continue to turn winch handle counterclockwise if the cable does not keep moving out under load. This will disengage the brake mechanism and will create an unsafe condition, which generally indicates that the cable pulley is stuck. Also, too much slack in cable could allow auger to drop suddenly. To correct the problem, winch in the slack cable and correct the sticking cable pulley.
- The winch must make a clicking sound when raising auger. If clicking sound stops, retain grip on handle, lower auger fully, and repair winch.
- After lowering auger, turn winch handle clockwise 2 clicks to lock winch brake.
- The winch is designed for manual operation only.
- Always keep a minimum of three cable wraps on winch drum.
- Ensure auger is empty and clear area before raising or lowering.
- Remember that auger uses a hand-operated winch that automatically locks into position. Ensure that winch is locked before operating.
- Do not get on or beneath auger when raising or lowering auger tube, or when auger is in transport position.
- When raising or lowering the tube, be aware of weight shift. If tube is allowed to drop, it will result in damage to tube and/or personal injury. Keep firm grip on winch handle.

## 2.5. HYDRAULIC SAFETY

---

- Wear proper hand and face protection when searching for hydraulic leaks. Escaping fluid under pressure can penetrate the skin, causing serious injury like gangrene. In case of accident, see a doctor immediately.
- Do not disconnect hydraulic couplers when hydraulic system is pressurized. For the correct procedure, consult this manual or your tractor manual.
- Relieve pressure before unhooking hydraulic lines.

## 3.8. ELECTRICAL HOOKUP

1. Connect either of the two wires on solenoid to one of the wires on the wiring harness (supplied), then cover connection with electrical tape.

**Note:** *The other wire on the solenoid is the ground wire. The solenoid must be properly grounded: connect a ground wire from the wagon frame to the other wire on the solenoid. Make certain the wire-connecting areas are free of paint, oil, and dirt.*

2. Leaving some slack at the solenoid, route the wiring harness down along the down spout.
3. Mount ON/OFF switch to the pre-drilled holes near the telescopic unload spout handle with two 1/4" x 1/2" bolts and whiznuts.
4. Fully extend telescoping unload spout and secure the wiring harness along spout with nylon ties.

**Note:** *Leave some slack in the wiring harness at the flexible portion of the unload spout.*

5. Run a 5 amp fused power wire (not supplied) from tractor power to the loose wire on wiring harness. Cover connection with electrical tape.

## 3.9. SPOUT HANGER

See Figure 3.15.

Bolt spout hanger clamp to tube using a 6" half clamp and two 7/16" x 1" bolts with locknuts. Position of the hanger clamp is determined by interference with any other components on auger tube; attach it out of the way so there is easy access to the spout strap.

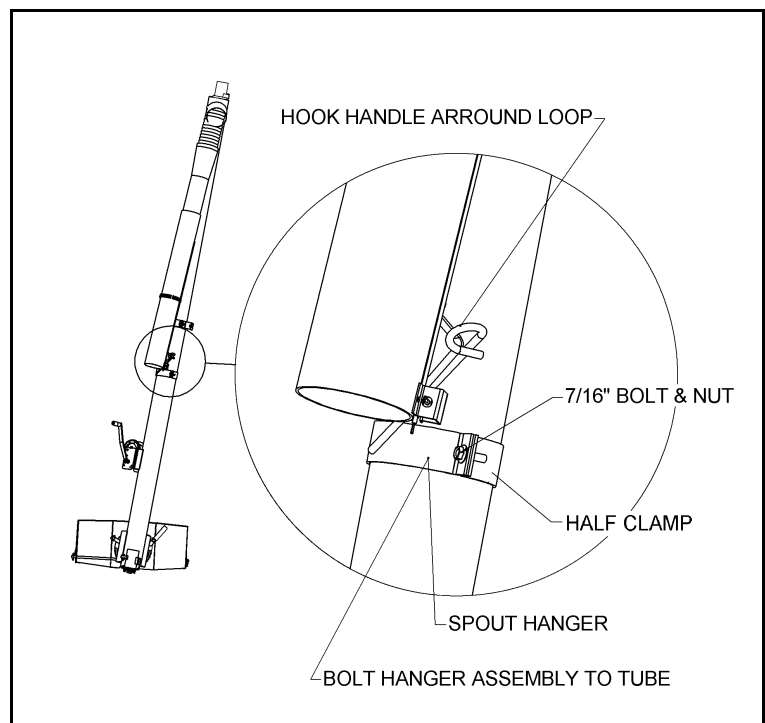

Figure 3.15



# 4. Operation

**Warning:** Before continuing, please reread the safety information relevant to this section at the beginning of this manual. Failure to follow the safety instructions can result in serious injury, death, or property damage.

## 4.1. PRE-OPERATIONAL CHECKLIST

---

Before operating auger each time, the operator must confirm the following:

- All fasteners are secure as per assembly instructions.
- Cable clamps are secure.
- Cable is not frayed, damaged, or kinked.
- Discharge hopper mount rod is not bent or cracked.
- Discharge hopper is securely mounted on mount rod with retaining pin in place.
- Intake area and discharge spout are free of obstructions.
- Cleanout cover is closed and secured with retaining pins in place and secure.
- Hydraulic hoses are in good condition.
- Hydraulic connections are in place and secure.
- Proper maintenance has been performed.

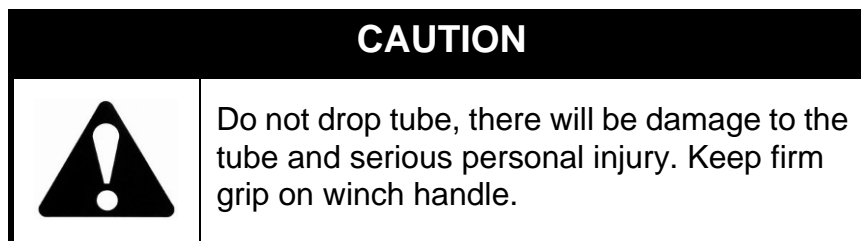

## 4.2. HYDRAULIC SPECIFICATIONS

---

- Required operating pressure is **1400 psi (13, 443 kPa)** at a maximum flow rate of **12 gpm**.
- Hose requirement: 3/8" diameter hydraulic hose.
- Pulsar 109-06-3/8" - 3000 psi WPSAE 100R17-30-99) complete with 3/8" NPTF male fitting.
- Length of hose is dependent on distance from wagon discharge to tractor hydraulics.

## 4.3. START-UP AND BREAK-IN

---

1. Complete the pre-operational checklist at the start of this section.
2. If everything is satisfactory, prepare for a 10 minute operation at half speed.
3. Position gravity wagon close to seeding equipment.
4. Correctly position the intake hopper.
5. Properly connect all hoses.
6. Unlock auger tube from transport bracket.
7. To position auger tube, turn winch and physically pull or push tube to the desired location.
8. Position auger tube and telescopic discharge spout to maximize product flow and dispersion to seeding equipment.
9. When desired auger position is obtained, lock auger tube into place by rotating support ring locking bar to lock position.

**Important:** *When starting gravity wagon auger for the first time, be prepared for an emergency shutdown in case of excessive vibration or noise. Note that the auger may run rough until tube is polished.*

10. Start tractor and **idle at low rpm**. Engage hydraulic flow lever.
11. Turn switch on telescopic spout to ON. Check that flighting is engaged and turning in the right direction.

**Important:** *In order to maintain proper grain flow through the discharge spout, hold spout at no less than 45° to the horizontal during operation. A more shallow angle could plug the downspout, resulting in damage to the equipment.*

12. Place telescopic unload spout in collection bin. Do not over-extend spout, as plugging will occur.
13. Gradually begin feeding grain into the discharge hopper.
  - Make sure that grain is being transported up the tube to discharge end.
  - Do not overfill the hopper on initial loads, keep feed of grain at about half capacity.
  - After auger tube is polished and runs smoothly, proceed to unload at the full speed of 500 rpm (flight rotation speed) and at full hopper capacity.

**Important:** *Always unload auger tube at the end of filling session or before transport mode.*

## 4.4. COMPLETION / CLEAN-UP

---

After operation, move the auger (along with gravity wagon) to the next work area or to a storage area. The recommended procedure is:

1. Lock out power.
2. Clean entire work area.
3. Empty auger. If necessary, manually clean out grain using a piece of wood, vacuum cleaner, or other tool. Do not use hands.
4. Auger can be completely disassembled from wagon or remain locked in transport position for storage.

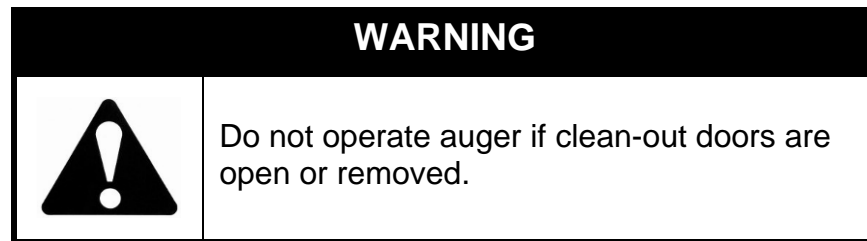

## 4.5. TRANSPORT

---

**Note:** Empty auger and lock it in transport position before transporting.

1. Unlock auger tube by rotating auger locking bar to unlocked position.
2. Push auger tube towards transport bracket. At the same time, adjust tube height to match bracket by turning winch handle.
3. Adjust auger tube height until locking pin is positioned inside transport bracket hole.
4. Release tension on cable. Let tube rest in bracket.
5. Lock tube into place by inserting hairpin.



# 5. Maintenance & Storage

**Warning:** Before continuing, please reread the safety information relevant to this section at the beginning of this manual. Failure to follow the safety instructions can result in serious injury, death, or property damage.

Proper maintenance habits on the gravity wagon auger mean a longer life, better efficiency, and safer operation.

## 5.1. MAINTENANCE PROCEDURES

---

We recommend the following steps for the general maintenance of the auger.

1. Observe the “Pre-Operational Checklist” on page 19 on a daily basis when auger is in use.
2. Check all operating, lifting, and transport components. Replace damaged or worn parts before using auger.

**Note:** *To replace a damaged part, refer to “Assembly” on page 11.*

## 5.2. STORAGE PROCEDURES

---

To protect auger in storage during the off-season, we suggest the following:

1. Remove all residual material from the hopper and tube.
2. Lock auger in transport position.
3. Release tension in cable, disconnect hoses, and plug up hydraulic openings.
4. Inspect auger for damage and note any repairs required. Order replacement parts from your dealer.



# 6. Troubleshooting

The Gravity Wagon Auger uses steel (or brush) fighting inside a steel tubing to convey material from the gravity wagon to other devices. It is a simple and reliable system that requires minimal maintenance.

In the following section, we have listed some causes and solutions to some of the problems you may encounter in the field.

If you encounter a problem that is difficult to solve, even after having read through this troubleshooting section, please call your local Westfield dealer or distributor. Before you call, please have this manual and the serial number from your machine ready.

<b>Problem</b>	<b>Cause</b>	<b>Solutions</b>
Auger runs too slow.	Tractor engine running too slow.	Increase engine speed.
	Tractor pump not producing required flow and pressure.	Check tractor pump capacity and correct.
	Hydraulic auger motor worn.	Repair or replace.
	Solenoid mounted wrong.	Mount solenoid to motor as per instructions.
	Hydraulic hose too small.	Replace with correct hose (3/8").
Auger won't run	Auger jammed.	Shut off and lock out power. Open cleanout doors and remove excess seed or fertilizer. Make sure discharge spout is clear.
	No hydraulic pressure to motor.	Check for correct attachment for hydraulic hoses and routing.
	No power to solenoid.	Correct or replace: burned fuse, poor ground-solenoid to wagon frame, wire connections at solenoid or control switch broken.
	Burned out solenoid.	Replace solenoid.
	Ports between hydraulic motor and solenoid blocked.	Remove solenoid and clean out obstruction.
	Solenoid mounted wrong.	Mount solenoid as per instructions.
	Poor grounding.	Properly ground solenoid to wagon frame or tractor.
Oil leaking at motor and solenoid connection.	Solenoid bolts loose.	Tighten bolts.
	O-rings damaged or not installed properly.	Remove solenoid and check that o-rings are properly installed. Replace if damaged.
Auger creeps when spout switch is shut off.	Oil flow (gpm) is too high.	Decrease oil flow (not pressure) to hydraulic motor with use of flow control valve. Flow must not exceed 12 gpm.
Solenoid won't function.	Poor ground.	Attach ground wire from solenoid to wagon frame.
	Solenoid mounted wrong.	Mount solenoid to motor as per instructions.



# WARRANTY

Westfield Industries Ltd. warrants products of its manufacture against defects in materials or workmanship under normal and reasonable use for a period of one year after date of delivery to the original purchaser.

Our obligation under this warranty is limited to repairing, replacing, or refunding defective part or parts which shall be returned to a distributor or a dealer of our Company, or to our factory, with transportation charges prepaid. This warranty does not obligate Westfield Industries Ltd. to bear the cost of labor in replacing defective parts. Any defects must be reported to the Company before the end of the one year period.

This warranty shall not apply to equipment which has been altered, improperly assembled, improperly maintained, or improperly repaired so as to adversely affect its performance. Westfield Industries Ltd. makes no express warranty of any character with respect to parts not of its manufacture.

The foregoing is in lieu of all other warranties, expressed or implied, including any warranties that extend beyond the description of the product, and the IMPLIED WARRANTY of MERCHANTABILITY is expressly excluded.

WESTFIELD INDUSTRIES LTD.

ROSENORT, MANITOBA

CANADA

ROG 1W0

***WESTFIELD***

Westfield is a Division of Ag Growth Industries LP

Part of the Ag Growth International Inc. Group

P.O. Box 39

Rosenort, Manitoba, Canada R0G 1W0

Phone: (866) 467-7207 (Canada & USA)

Fax: (866) 768-4852

website: [www.grainaugers.com](http://www.grainaugers.com)

email: [sales@grainaugers.com](mailto:sales@grainaugers.com)

© Ag Growth Industries Limited Partnership 2009

Printed in Canada