

WESTFIELD®

MK FLEX AUGER 71' - 111' ASSEMBLY & OPERATION MANUAL



Read this manual before using product. Failure to follow instructions and safety precautions can result in serious injury, death, or property damage. Keep manual for future reference.

Part Number: 30650 R0

Revised: 5/10/09

TABLE OF CONTENTS

1. Introduction	5
2. Safety First.....	7
2.1. General Safety	8
2.2. Assembly Safety.....	9
2.3. Operation Safety	9
2.4. PTO Safety	11
2.5. Hydraulic Safety	11
2.6. Transport and Placement Safety	12
2.7. Maintenance Safety.....	13
2.8. Safety Decal Locations.....	13
2.8.1. Decal Installation	14
2.8.2. Decal Locations	14
3. Assembly	19
3.1. Tubes & Flighting	19
3.2. Flex Frame Components	26
3.3. Flex Tube Assembly	28
3.4. Flex Tube to Flex Frame Connection	30
3.5. Discharge Spout and Thrust Adjuster	31
3.6. Track Shoe, Trackstop, & Lift-Assist Arm (71'–81').....	32
3.7. Track Shoe, Trackstop, & Lift-Assist Arm (91'–111').....	33
3.8. Adjustable Towbar.....	34
3.9. Truss (71'–81')	35
3.10. Truss (91'–111')	38
3.10.1. Cable Trussing	40
3.11. Transport Undercarriage (71'–81')	41
3.12. Transport Undercarriage (91'–111')	46
3.13. Lift Cables	50
3.13.1. MK Flex 71'	50
3.13.2. MK Flex 81'	52
3.13.3. MK Flex 91' - 111'	52
3.14. Hydraulic Hoses	53
3.14.1. MK Flex 71'	53
3.14.2. MK Flex 81'	54
3.14.3. MK Flex 91'–111'	56
3.15. PTO (CV) Driveline.....	58
3.16. Low Profile Hopper	59
3.16.1. Hopper Lift Arm / Winch	69
3.17. Flex Auger Hydraulics	70
3.17.1. Open to Closed Center Conversion.....	73
3.18. Hitch Jack.....	73

TABLE OF CONTENTS

3.19. Auger-to-Tractor Hookup	73
3.19.1. PTO Driveline / Drawbar	74
3.19.2. Hydraulic Hose Couplers	77
3.20. Plastic Manual Holder.....	77
4. Transport & Placement	79
4.1. Pre-Transport Checklist.....	79
4.2. Transport Procedure.....	80
4.3. Pre-Placement Checklist	81
4.4. Placement Procedure	83
5. Operation	87
5.1. Pre-Operational Checklist.....	87
5.2. Connecting Auger PTO Driveline	88
5.3. Auger Operation and Break-In.....	88
5.3.1. Before Starting.....	89
5.3.2. Operation and Break-In Instructions	89
5.3.3. After Operating 30 Minutes.....	91
5.3.4. After Operating For 5 and 10 Hours	91
5.3.5. Shutdown.....	91
5.3.6. Emergency Shutdown.....	91
5.3.7. Full-Tube Restart	92
5.4. Lowering Auger	92
6. Maintenance & Storage.....	95
6.1. General Maintenance Procedures.....	95
6.2. Storage	98
7. Troubleshooting	101
8. Appendix.....	105
8.1. Specifications	105
8.2. Lift Cylinder Hydraulics (81'/91'/111')	106
8.2.1. Special Notes.....	107
Warranty.....	109

1. Introduction

Congratulations. As the new owner of a grain auger, you will be working with equipment designed to complement and improve your farming operation. Before using this auger, please read this manual and all safety labels and familiarize yourself with the various features of the machine and the necessary precautions for efficient and safe operation.

In addition, anyone using this auger is required to comply with all safety precautions in this manual and in safety labels attached to the auger. A sign-off form is supplied on the inside front cover to record your safety reviews.

Thank you.

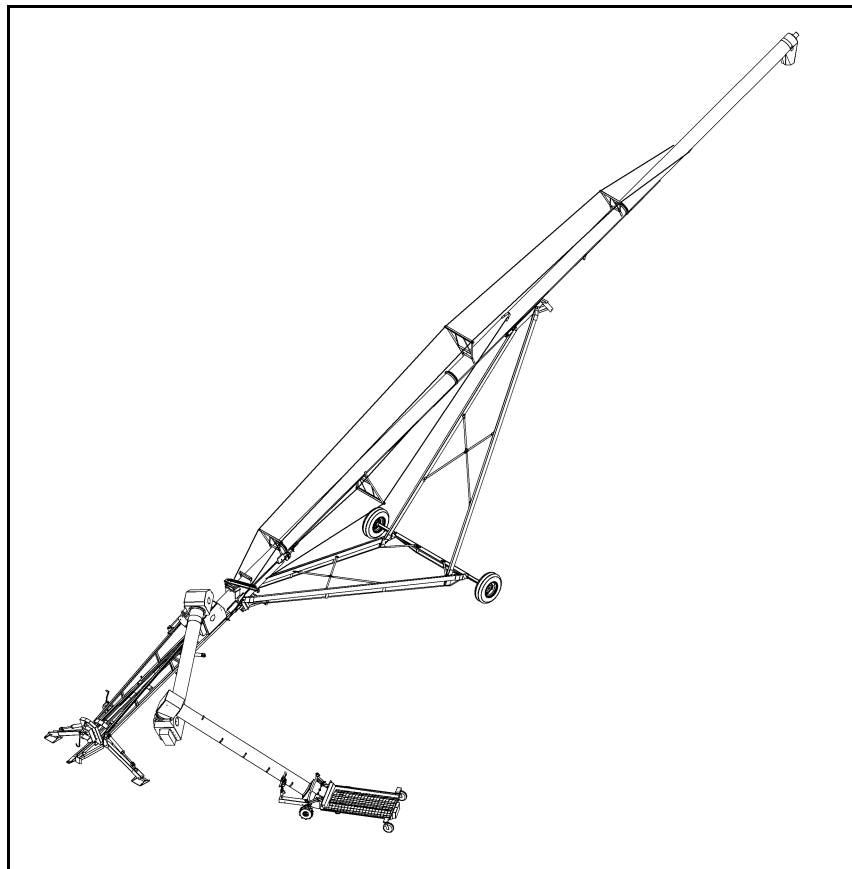

Serial Number:	
*Serial number is located on the lower tube.	

2. Safety First



The Safety Alert symbol to the left identifies important safety messages on the product and in the manual. When you see this symbol, be alert to the possibility of personal injury or death. Follow the instructions in the safety messages. Why is SAFETY important to you?

Three big reasons:

- Accidents disable and kill.
- Accidents cost.
- Accidents can be avoided.

SIGNAL WORDS

Note the use of the signal words **DANGER**, **WARNING**, **CAUTION**, and **NOTICE** with the safety messages. The appropriate signal word for each message has been selected using the definitions below as a guideline.

The Safety Alert symbol means ATTENTION, BE ALERT!, YOUR SAFETY IS INVOLVED.

DANGER	
	Indicates an imminently hazardous situation that, if not avoided, will result in serious injury or death.

WARNING	
	Indicates a hazardous situation that, if not avoided, could result in serious injury or death.

CAUTION	
	Indicates a hazardous situation that, if not avoided, may result in minor or moderate injury.

NOTICE	
	Indicates a potentially hazardous situation that, if not avoided, may result in property damage.

2.1. GENERAL SAFETY

Important: *The general safety section includes instructions that apply to all safety practices. Any instructions specific to a certain safety practice (e.g., assembly safety), can be found in the appropriate section. Always read the complete instructional sections and not just these safety summaries before doing anything with the equipment.*

YOU are responsible for the **SAFE** use and maintenance of your equipment. **YOU** must ensure that you and anyone else who is going to work around the equipment be familiar with all procedures and related **SAFETY** information contained in this manual.

Remember, **YOU** are the key to safety. Good safety practices not only protect you, but also the people around you. Make these practices a working part of your safety program.

- The most important safety device on this equipment is a **SAFE** user or operator. It is the user/operator's responsibility to read and understand **ALL** safety instructions, safety decals, and manuals and follow them before assembly, operating, or maintaining the equipment. All accidents can be avoided.
- A person who has not read and understood all safety instructions is not qualified to operate or use the equipment. Untrained users/operators expose themselves and bystanders to possible serious injury or death.
- Equipment owners must give instructions to employees before allowing them to operate or use the product.
- Review safety information initially and annually with all personnel who will be using the product.
- Use this equipment for its intended purposes only.
- Do not modify the equipment in any way. Unauthorized modification may impair the function and/or safety, and could affect the life of the equipment. Any modification to the equipment voids the warranty.
- Do not allow children, spectators, or bystanders within the work area.
- Have a first-aid kit available for use should the need arise, and know how to use it.
- Provide a fire extinguisher for use in case of an accident. Store in a highly visible place.
- Wear appropriate protective gear. This list includes, but is not limited to:



- a hard hat
- gloves
- protective shoes with slip-resistant soles
- protective goggles
- hearing protection



- Before servicing, adjusting, or repairing powered equipment, unplug, place all controls in neutral or off position, stop the engine or motor, remove ignition key or lock out power source, and wait for all moving parts to stop.
- Follow good shop practices:
 - keep service area clean and dry
 - be sure electrical outlets and tools are properly grounded
 - use adequate light for the job at hand
- Think SAFETY! Work SAFELY!



2.2. ASSEMBLY SAFETY

- Read through the instructions to get to know the subassemblies and hardware that make up the equipment.
- Do not take chances with safety. The components are large, heavy, and can be hard to handle. Always use the proper tools, stands, jacks, and hoists for the job.
- Always have 2 or more people assembling the equipment. Because of the weight, do not attempt assembly alone.

2.3. OPERATION SAFETY

- Have another trained person nearby who can shut down the auger in case of an accident. Always work with a second trained person around augers.
- Do not operate with any of the safety guards removed.
- Keep body, hair, and clothing away from moving parts. Stay away from intake during operation.
- Inspect lift cable before using auger. Replace if frayed or damaged. Make sure it is seated properly in cable sheaves and cable clamps are secure.
- Operate auger on level ground free of debris. If ground is uneven, anchor the auger to prevent tipping or upending.
- Augers are not insulated. Keep away from electrical lines. Electrocution can occur without direct contact.
- Support the discharge end and/or anchor the intake end before operating to prevent upending.
- Do not use auger as a hoist.
- Empty auger before raising or lowering.
- Lower auger at completion of operation or when not in use. Auger could drop rapidly if the cable breaks or if the hydraulics fail (where applicable).
- Do not operate auger with the service or cleanout doors open or unlatched.

- Do not get on or beneath auger when raising or lowering intake hitch jack, or when auger is supported by hitch jack.
- Do not operate auger with intake hopper in transport position. This will cause damage to the u-joint.

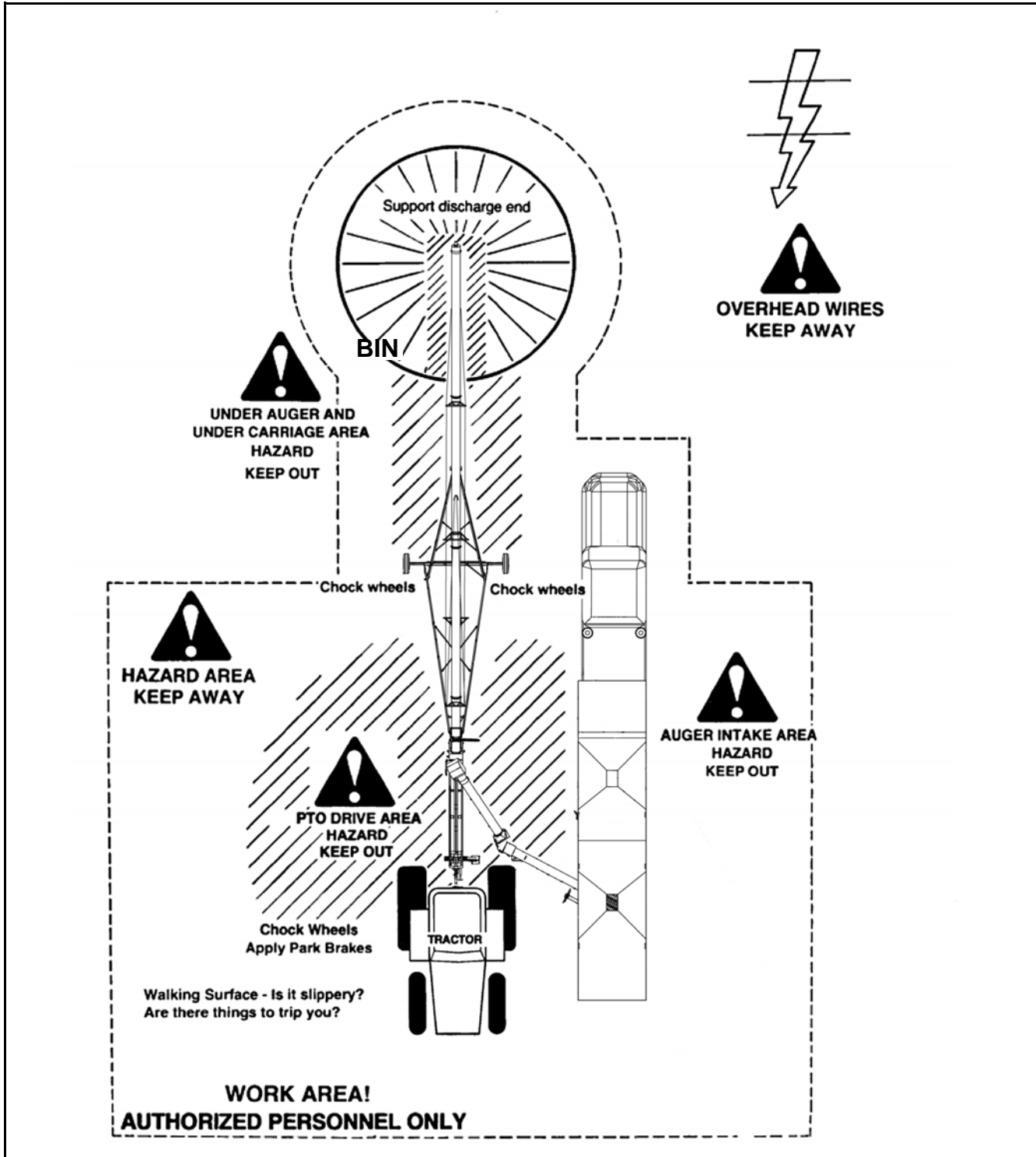

Figure 2.1

2.4. PTO SAFETY

- Never use a PTO driveline without a rotating guard in good working order.
- Ensure PTO driveline is securely attached at both ends.
- Before starting tractor, turn power to PTO to the off position (where applicable).
- Keep body, hair, and clothing away from rotating PTO driveline.
- Ensure the driveline shields turn freely on driveline.
- Do not exceed operating speed of 540 rpm.
- Keep u-joint angles small and equal. Do not exceed recommended operating length for PTO driveline.

2.5. HYDRAULIC SAFETY

- Wear proper hand and face protection when searching for hydraulic leaks. Escaping fluid under pressure can penetrate the skin, causing serious injury like gangrene. In case of accident, see a doctor immediately.
- Fluid leaks in the hydraulic lift cylinders or hoses will allow the auger to lower inadvertently. Repair all leaks and breaks immediately. Rupture could cause damage and/or personal injury.
- A hydraulic lift is faster than a conventional hand crank—always clear area of personnel before raising or lowering.
- Do not disconnect hydraulic couplers when hydraulic system is pressurized. For the correct procedure, consult this manual or your tractor manual.
- Relieve pressure before unhooking hydraulic lines.
- Inspect hydraulic fittings and hoses for damage on a daily basis. Repair if damaged.
- Ensure that the hydraulic line is properly connected and secure.
- Keep hydraulic line away from moving parts.
- Clean connections before connecting to equipment.

2.6. TRANSPORT AND PLACEMENT SAFETY

- Transport auger in full down position with slight tension on cable.
- Properly place hitch pin and securely attach safety chain. Use a type of hitch pin that will not allow auger to separate from towing vehicle.
- Always attach an SMV (slow moving vehicle) sign before transporting auger. Equip the auger with the necessary lights for transportation where required by law. Always use hazard warning flashers on the tractor/towing vehicle when transporting, unless prohibited by law.
- Always travel at a safe speed, never exceeding 15 mph (24 km/hr). Reduce speed on rough surfaces and be cautious when turning corners or meeting traffic.
- Before raising/lowering/moving the auger, make sure the area around the auger is clear of obstructions and/or untrained personnel. Never allow anyone to stand on or beneath auger while transporting or placing auger.
- Do not transport auger on slopes greater than 20°.
- Wheels must be free to move when raising or lowering auger.
- Never attempt to move auger manually. To do so will result in serious injury.
- Before moving auger, check for overhead obstructions and/or electrical wires. Electrocutation can occur without direct contact.
- Disconnect PTO driveline from tractor before moving auger or tractor, and secure driveline in transport saddle (where applicable).

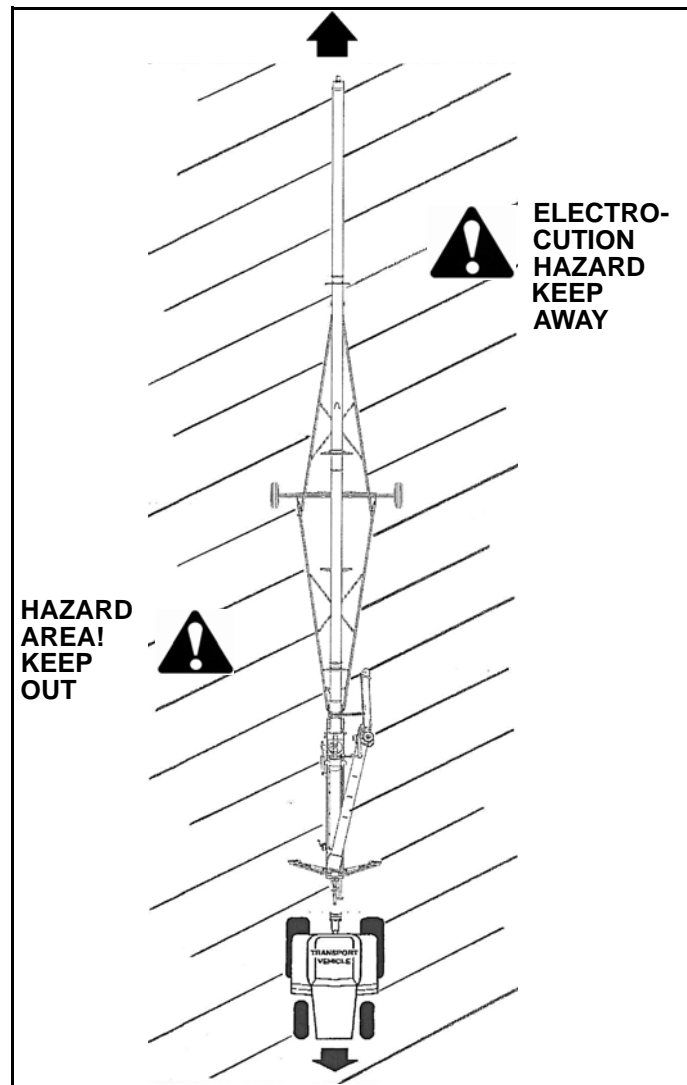

- Raise intake feed hopper into transport position and lock hopper lift winch before transporting or moving auger. Intake feed side of hopper must face main auger when in transport position.
- Do not operate auger with intake hopper in transport position. This will cause damage to the u-joint.
- Not intended for transport on public roads. If auger must be moved, check local length and width regulations. Be careful when turning corners. Watch for low overhead objects. Retract axles before transporting unit.

The Flex Auger exceeds hitch weight capacity for most trucks and must be towed with appropriate equipment. A tractor is recommended. Refer to the Specifications Section in the Appendix for details on the weight of this machine. Check with your local dealer if you are unsure.

2.7. MAINTENANCE SAFETY

- Shut down and lock out all power before attempting maintenance of any kind. If applicable, disconnect PTO driveline from tractor or hydraulic hoses on units with hydraulic drive hoppers.
- After maintenance is complete, replace and secure all safety guards and safety devices, and if applicable, service doors and cleanout covers.
- Support auger tube before attempting maintenance on the undercarriage assembly. Auger should be in full down position for maintenance.
- Use only genuine Westfield replacement parts or equivalent. Replacement parts such as intake guards, pulley guards, PTO driveline shields, winches, and lift cables must meet ASABE standards or serious injury may result. Use of unauthorized parts will void warranty. If in doubt, contact Westfield or your Westfield dealer.
- Do not modify any auger components without authorization from Westfield. Modification can be dangerous and result in serious injuries.

2.8. SAFETY DECAL LOCATIONS

- Keep safety decals clean and legible at all times.
- Replace safety decals that are missing or have become illegible. See decal location figures below.
- Replaced parts must display the same decal(s) as the original part.
- Safety decals are available from your distributor, dealer, or factory.

2.8.1. DECAL INSTALLATION

1. Decal area must be clean and dry, with a temperature above 10°C (50°F).
2. Decide on the exact position before you remove the backing paper.
3. Align the decal over the specified area and carefully press the small portion with the exposed sticky backing in place.
4. Slowly peel back the remaining paper and carefully smooth the remaining portion of the decal in place.
5. Small air pockets can be pierced with a pin and smoothed out using the sign backing paper.

2.8.2. DECAL LOCATIONS

Replicas of the safety decals that are attached to the equipment are shown below. Good safety requires that you familiarize yourself with the various safety decals and the areas or particular functions that the decals apply to as well as the safety precautions that must be taken to avoid serious, injury, death, or damage.

** Westfield Industries reserves the right to update safety decals without notice. Safety decals may not be exactly as shown.*

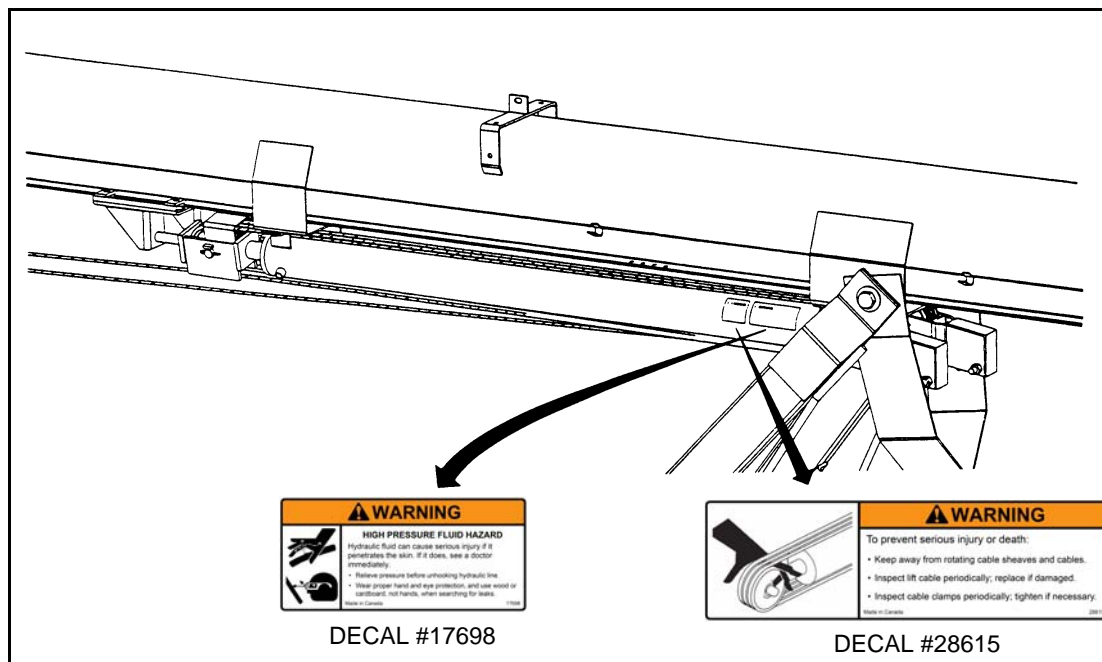

Figure 2.2

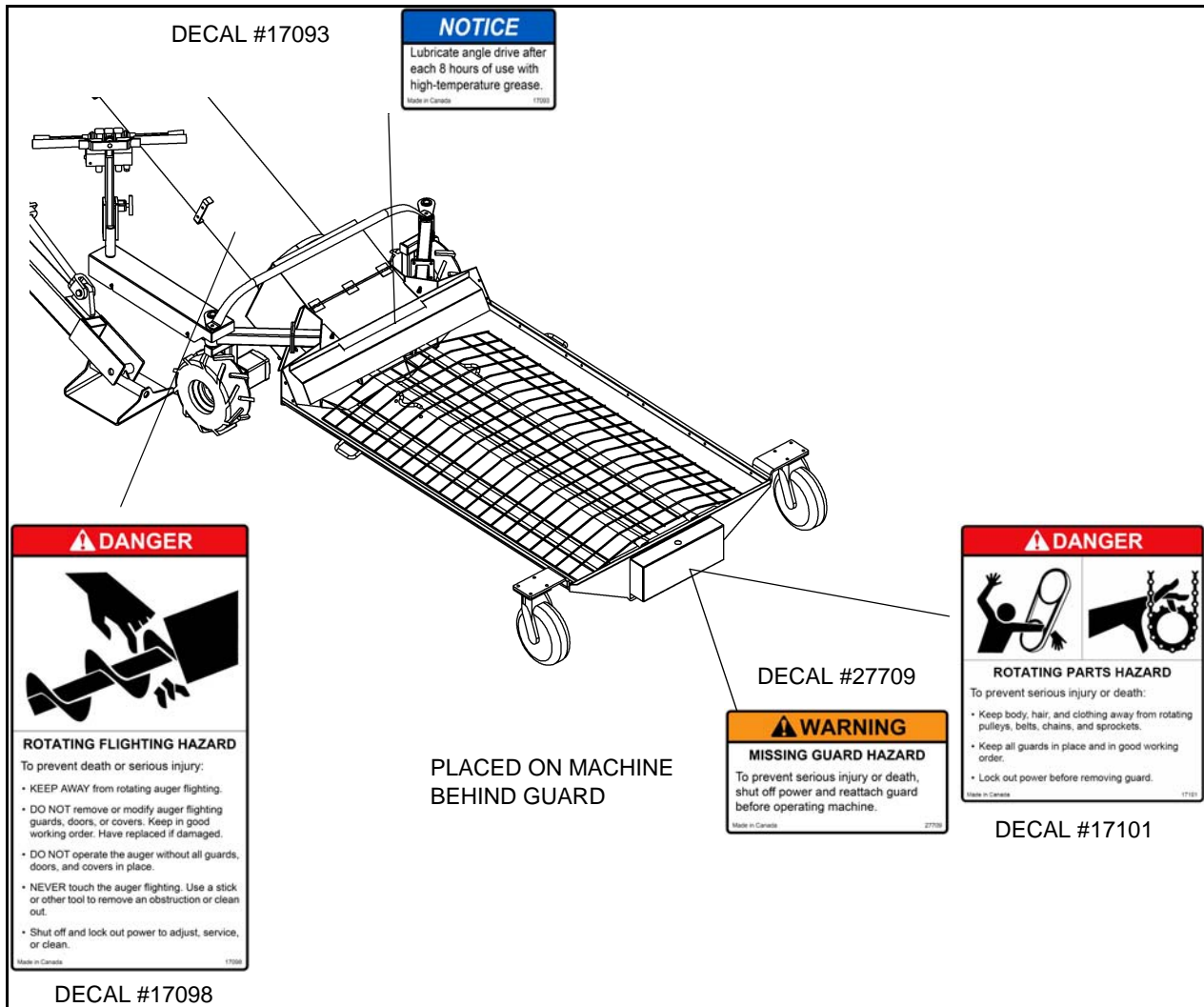
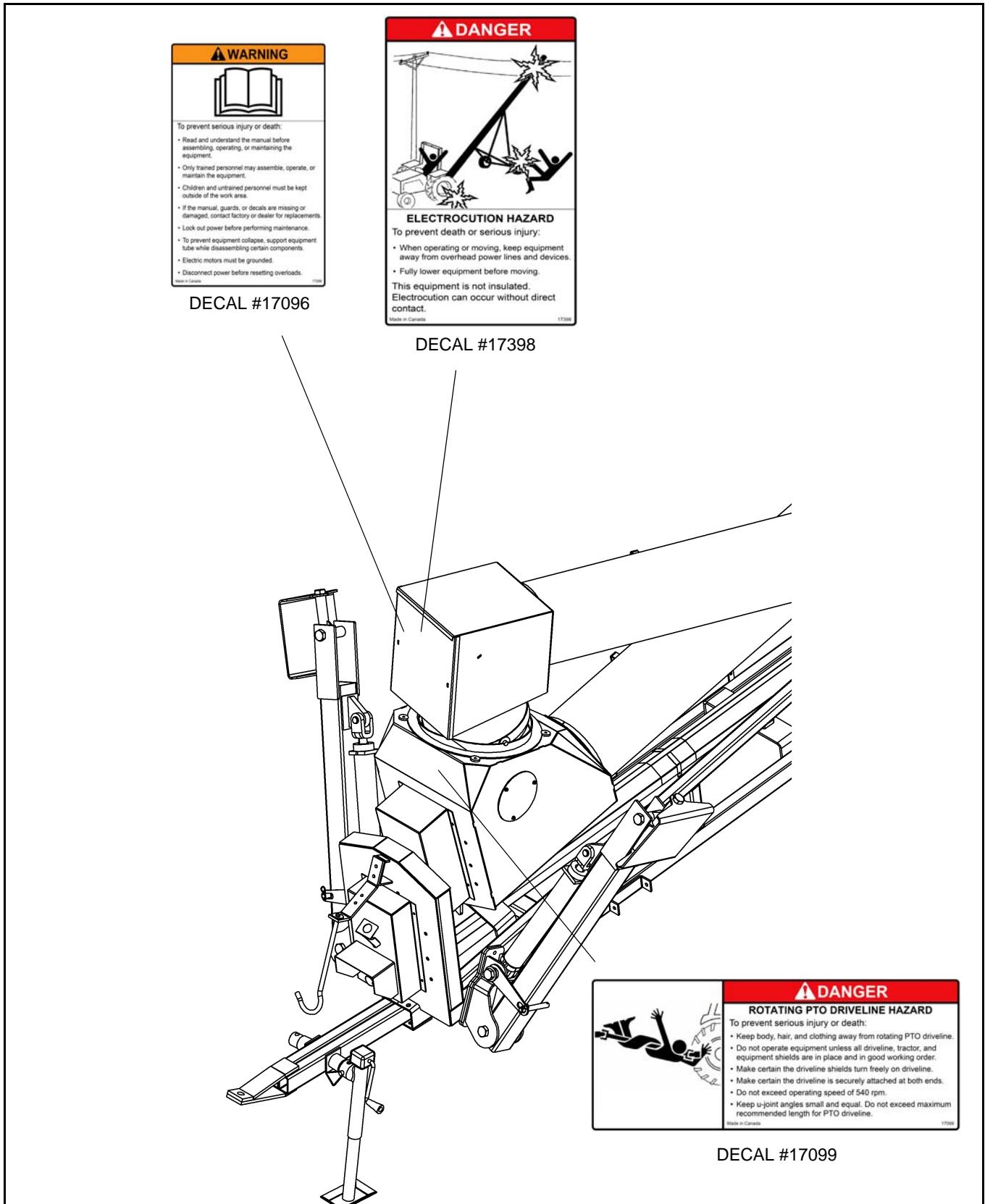
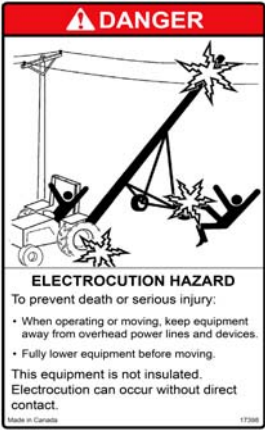

Figure 2.3



DECAL #17096



DECAL #17398



DECAL #17099

Figure 2.4

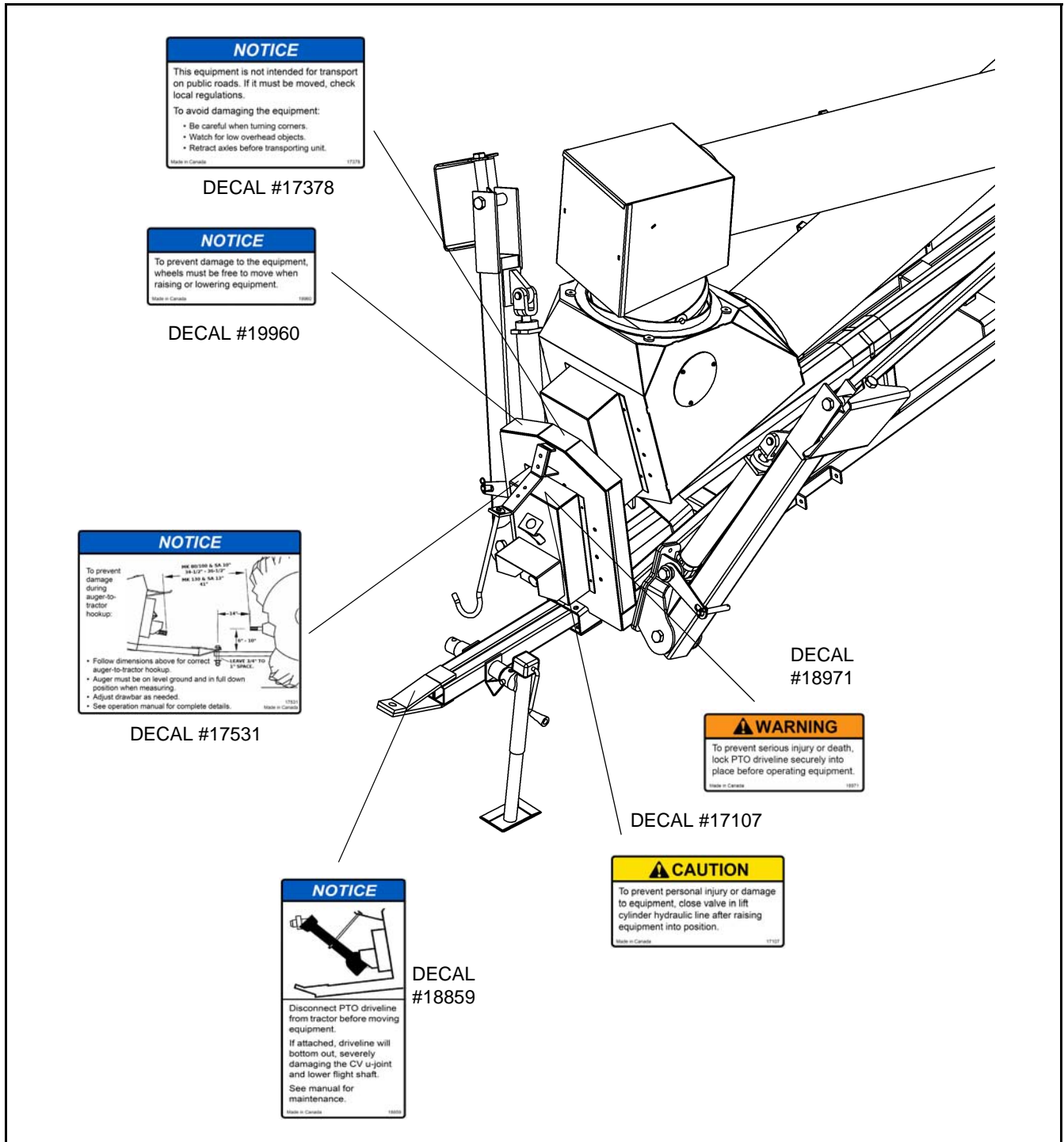

Figure 2.5

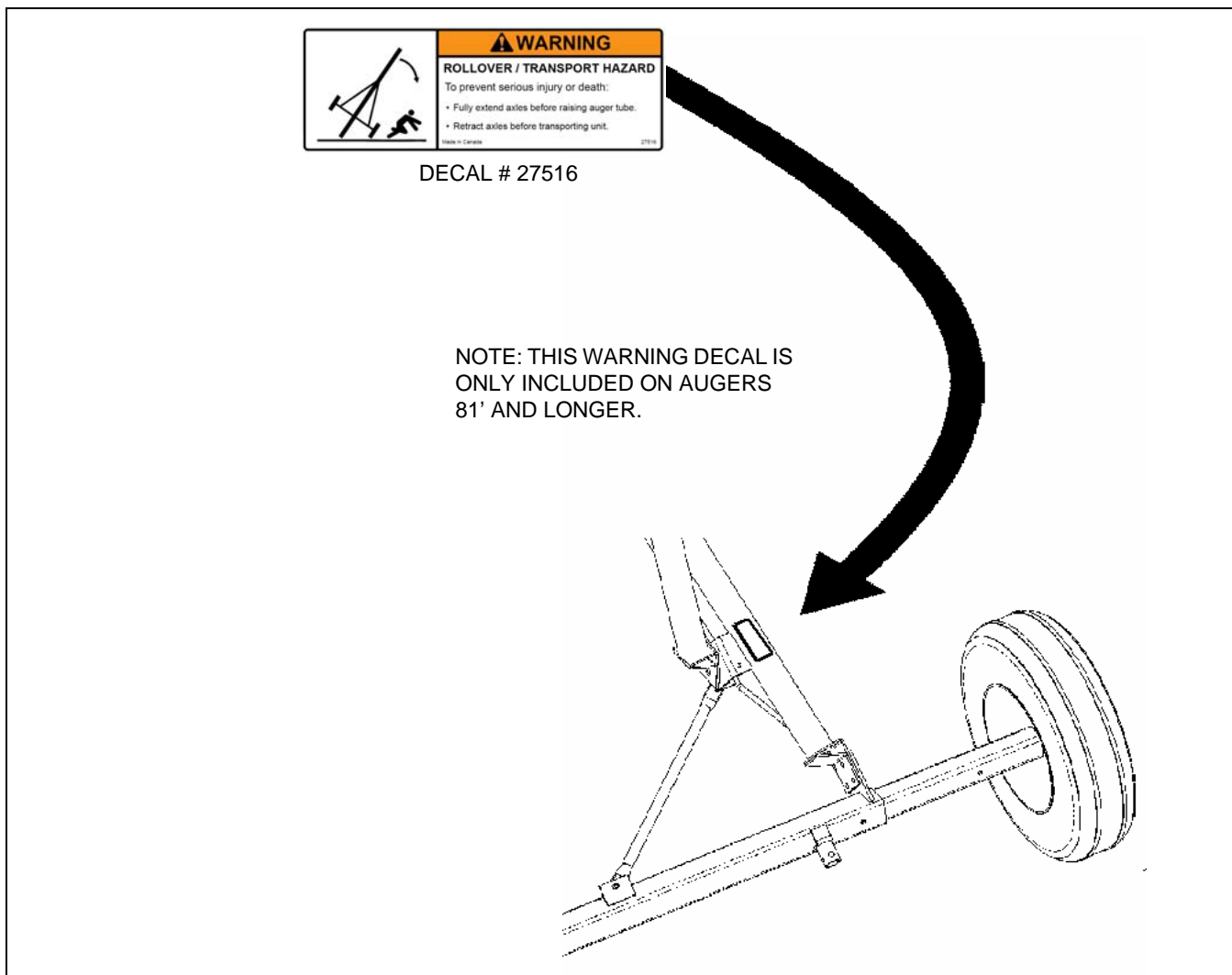

Figure 2.6

Important: *Please review the decals shown. If your auger does not have these decals, they are available upon request. Please specify which decals you need.*

4. Transport & Placement

WARNING

Before continuing, please reread the safety information relevant to this section at the beginning of this manual. Failure to follow the safety instructions can result in serious injury, death, or property damage.

This auger is designed to be transported and operated without unhitching unit from tractor.

4.1. PRE-TRANSPORT CHECKLIST

1. Use appropriate equipment to transport the Flex Auger. The Flex Auger exceeds the hitch weight capacity of most trucks. A tractor is recommended. Refer to the Specifications Section in the Appendix for details on the weight of this machine. Check with your local dealer if you are unsure of your towing capacity.
2. Ensure auger is in full down-position with PTO driveline disconnected from tractor. The trackshoe must be seated against the trackstop with slight tension on the lift cable.

Important: *Check lift cable before each use. Replace if frayed or damaged.*

3. Check that the flex tube is locked in place with the saddle pin (Figure 4.3).
4. Intake feed hopper is raised into transport position, lift cable is connected to and secured with saddle pin and hairpin (see Figure 4.1).

NOTICE

Do not operate auger with intake hopper in transport position. This will damage the u-joint.

5. Outrigger legs are raised and locked in transport position (see Figure 4.3).

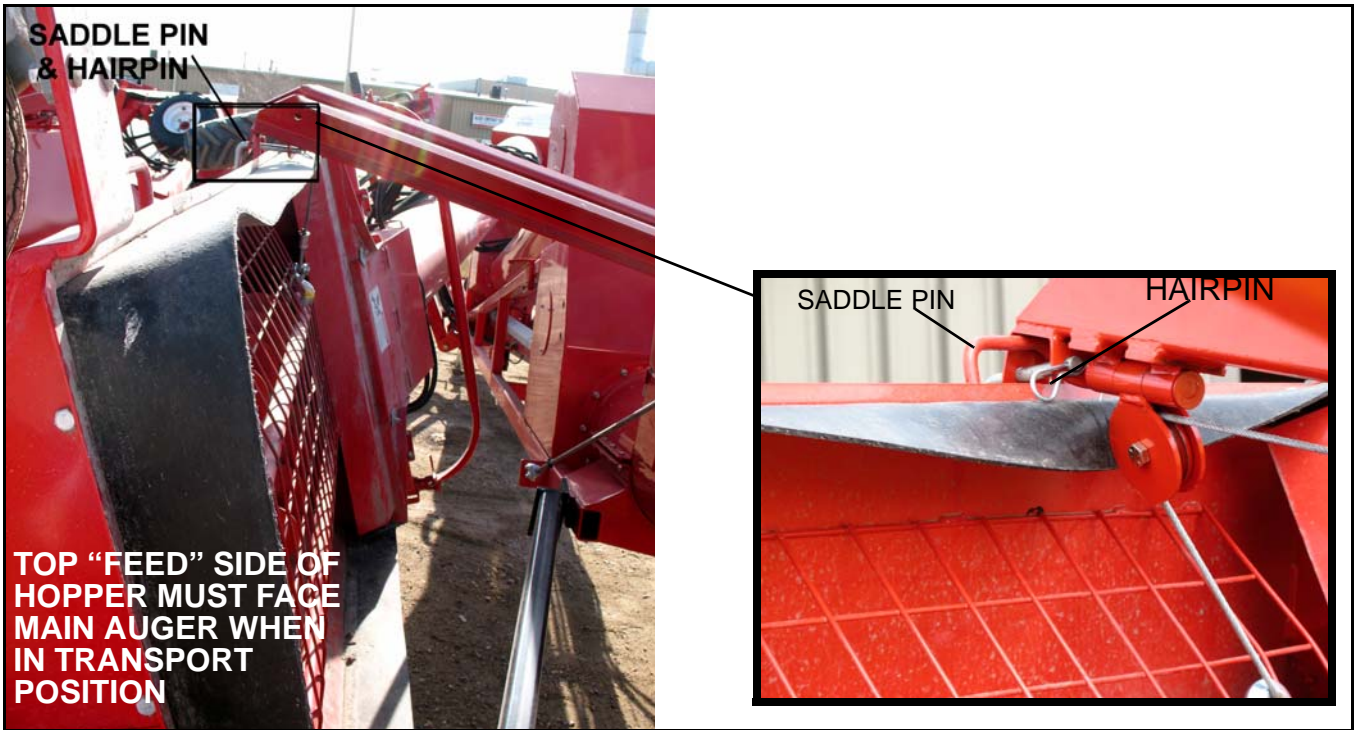

Figure 4.1

4.2. TRANSPORT PROCEDURE

1. Connect the hitch pin and safety chain in place and secure. Place safety chain through clevis welded to auger hitch tube and bolt together before attaching to tractor (see Figure 4.2).

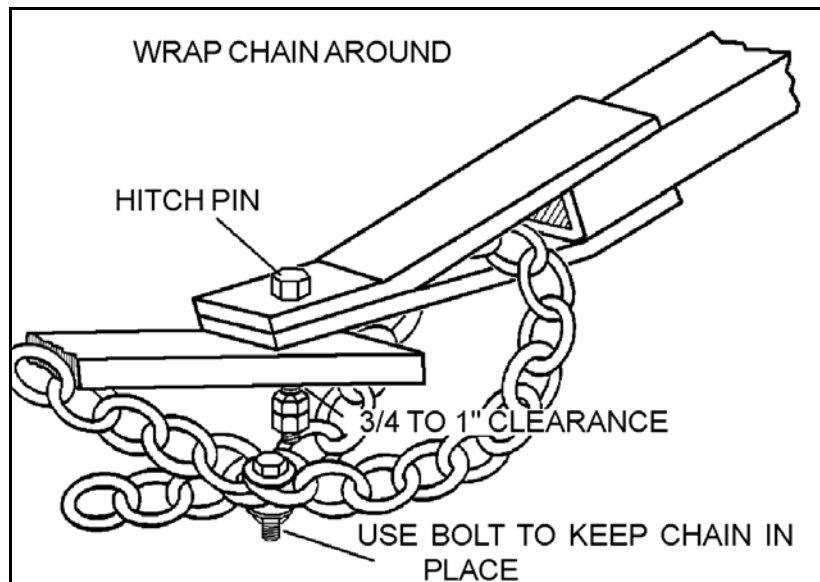



Figure 4.2

2. Place the swivel jack (on side of hitch) in transport position and lock.

WARNING	
	If auger wheels are partially or fully buried in snow or grain, failure to clear the area around the wheels before moving may cause damage to the auger or result in serious injury.

WHEN TRANSPORTING THE AUGER:

- Tow auger at speeds less than than 15 mph (24 km/h).

WARNING	
	Watch for overhead obstructions and electrical wires and devices. The 71' augers require minimum clearances of 12', the 81' augers require 10'7", the 91' augers require 12'6", and the 111' augers require a minimum clearance of 15'.

- Observe all regulations concerning marking, towing, and maximum width.
- Equip the auger with the necessary lights where required by law.
- Do not transport auger on slopes greater than 20°.
- Use extreme caution turning and cornering when towing auger.

4.3. PRE-PLACEMENT CHECKLIST

1. PTO driveline is disconnected from tractor and secured in transport saddle.

NOTICE
When positioning, PTO driveline must be disconnected from the tractor and placed in the transport saddle to prevent damage to auger and PTO driveline.

2. Ensure that the auger is on reasonably level ground when raising, lowering, or when positioning.

Important: *Auger could topple if ground is too uneven, damaging equipment and/or causing injury.*

3. Before raising or positioning auger, ensure that entire area, both on the ground and overhead, is clear of any obstructions or electrical wires.

DANGER	
	Watch for overhead electrical wires. Electrocution can occur without direct contact. Failure to heed this warning will result in serious injury or death.

4. Towing hitch is positioned and secured.

Important: Use a type of hitch pin that has proper clearance and will not allow auger to separate from towing vehicle. Refer to Figure 4.2.

WARNING	
	Auger must be hooked up to tractor for all operations including transport, raising, placement, and augering grain. Never attempt to move auger manually; doing so will result in serious injury.

5. Because of the many different kinds of tractor hydraulic systems, the quick-connect coupler must be supplied by the owner. Please consult your tractor manual or dealer for the proper coupler.
 - Before connecting hose, ensure that the quick-connect coupler on auger and tractor is clean and free of dirt by wiping with a cloth.

NOTICE	
Dirt in the hydraulic system can damage the cylinder o-rings, causing leakage and the possible failure of the system and personal injury.	

4.4. PLACEMENT PROCEDURE

1. Connect hydraulic hoses tightly. Check for leaks, binding, flattening, kinks, or wear.
2. To raise the auger for positioning:
 - a. Check that valve on hose to lift cylinder is open.
 - b. Check that the area above and around the auger is clear.
 - c. Raise auger to the desired height using tractor hydraulic controls.

Note: *Wheels must move freely when raising or lowering auger.*

- d. Close hose valve after auger is positioned.

Important: *The hydraulic cylinders are shipped without oil and must be charged with oil before auger is put into operation. See the "Lift Cylinder Hydraulics (81'/91'/111')"* on page 106 for charging instructions.

WARNING



Fluid leaks in the hydraulic cylinder or hose will allow auger to lower inadvertently.

Repair all leaks and breaks immediately.

CAUTION



If hose valve remains open, a loss of hydraulic pressure within the tractor system will allow the auger to lower inadvertently, damaging equipment and/or causing personal injury.

3. Move the auger into working position slowly, making sure that there is no one in the hazard zone; refer to Figure 2.1 on page 10 . Do not unhitch and attempt to move auger by hand.

NOTICE	
When positioning the Flex auger, the PTO driveline must be disconnected from the tractor and placed in the transport saddle to prevent damage to auger and PTO driveline.	

WARNING	
	Never attempt to increase height of auger by positioning wheels on lumber, blocks, or by any other means. To do so will result in damage to equipment and/or serious injury.

4. Once the auger is in position, connect and secure the main hydraulic lines to the tractor.

Important: *If your tractor is equipped with a single hydraulic system, relieve pressure and disconnect lift hose to connect main hydraulic system hoses. Do not disconnect the hydraulic couplers when under pressure. Refer also to the tractor manual.*

WARNING	
	Escaping hydraulic fluid under pressure can cause serious injury if it penetrates the skin. Wear protective clothing when working around hydraulic equipment.

5. Clear hydraulic hoses away from any moving parts.
6. Lower outrigger legs by removing retaining pin and engaging tractor hydraulics. Close ball valve located on outrigger leg to secure legs once fully lowered (Figure 4.3).

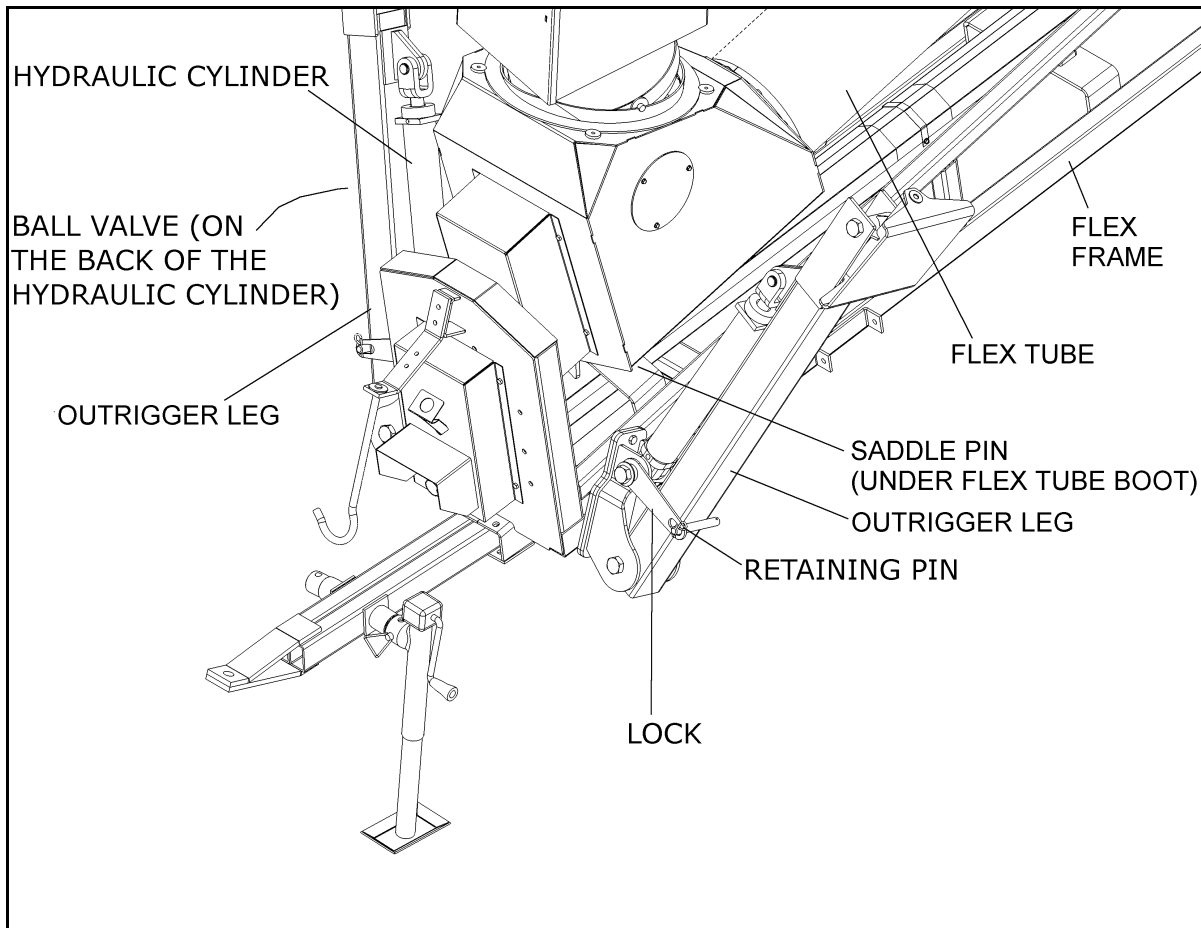

Figure 4.3

7. Chock wheels on both sides and apply the park brake on the tractor (or chock its wheels as well) to prevent movement during operation.
8. Remove the saddle pin and hairpin holding the swing hopper in place.
9. Using the winch on the side of the auger, fully lower the swing hopper to the ground and remove lift cable.
10. Under the flex tube boot, rotate the saddle pin downwards to lock, this allows the flex tube to move during operation (Figure 4.3).

WARNING



Do not use auger as a hoist to raise any object regardless of weight. Doing so could result in serious injury, death or damage to the auger or item being lifted.

5. Operation

WARNING

Before continuing, please reread the safety information relevant to this section at the beginning of this manual. Failure to follow the safety instructions can result in serious injury, death, or property damage.

5.1. PRE-OPERATIONAL CHECKLIST

Operators must observe safety procedures at all times and follow the pre-operational checklist before each start-up.

Before operating auger each time, the operator must confirm the following:

- All fasteners are secure as per assembly instructions.
- Cable clamps are secure.
- Lift cable is not frayed or damaged.
- Lift cable is properly seated in cable sheaves.
- Hydraulic hoses are in good condition.
- Hydraulic connections are in place and secure.
- PTO driveline is connected and secure.
- PTO driveline shield rotates freely.
- Clean-out and service doors and access covers are in place and secure and safety discharge door is closed.
- All safety guards are in place and secure.
- Tube alignment is reasonably straight.
- Intake area and discharge spout are free of obstructions.
- Auger wheels are chocked, and if necessary, tractor wheels are chocked or the parking brake has been engaged.
- Proper maintenance has been performed.
- Tractor and auger are in line or as close to being in line as possible.
- The saddle pin under the main boot is released to allow it to move during operation.
- Know how to shut down the auger safely in case of an emergency.

5.2. CONNECTING AUGER PTO DRIVELINE

1. Place PTO drive on the tractor in the off position.
2. Engage tractor park brake and/or chock tractor wheels.
3. Securely attach PTO driveline to the tractor.
4. Check to ensure you are not exceeding the maximum operating length of the PTO driveline. Refer to "Auger-to-Tractor Hookup."

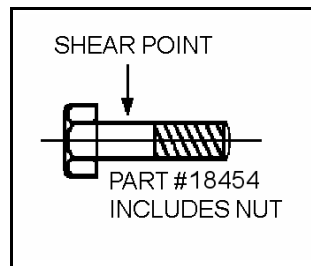

Note: *If shearbolt in PTO driveline fails, shut down and lock out tractor to replace bolt.*

5.3. AUGER OPERATION AND BREAK-IN

CAUTION	
	Auger must be hooked up to tractor for all operations, including transport, raising, placement, and augering of grain.

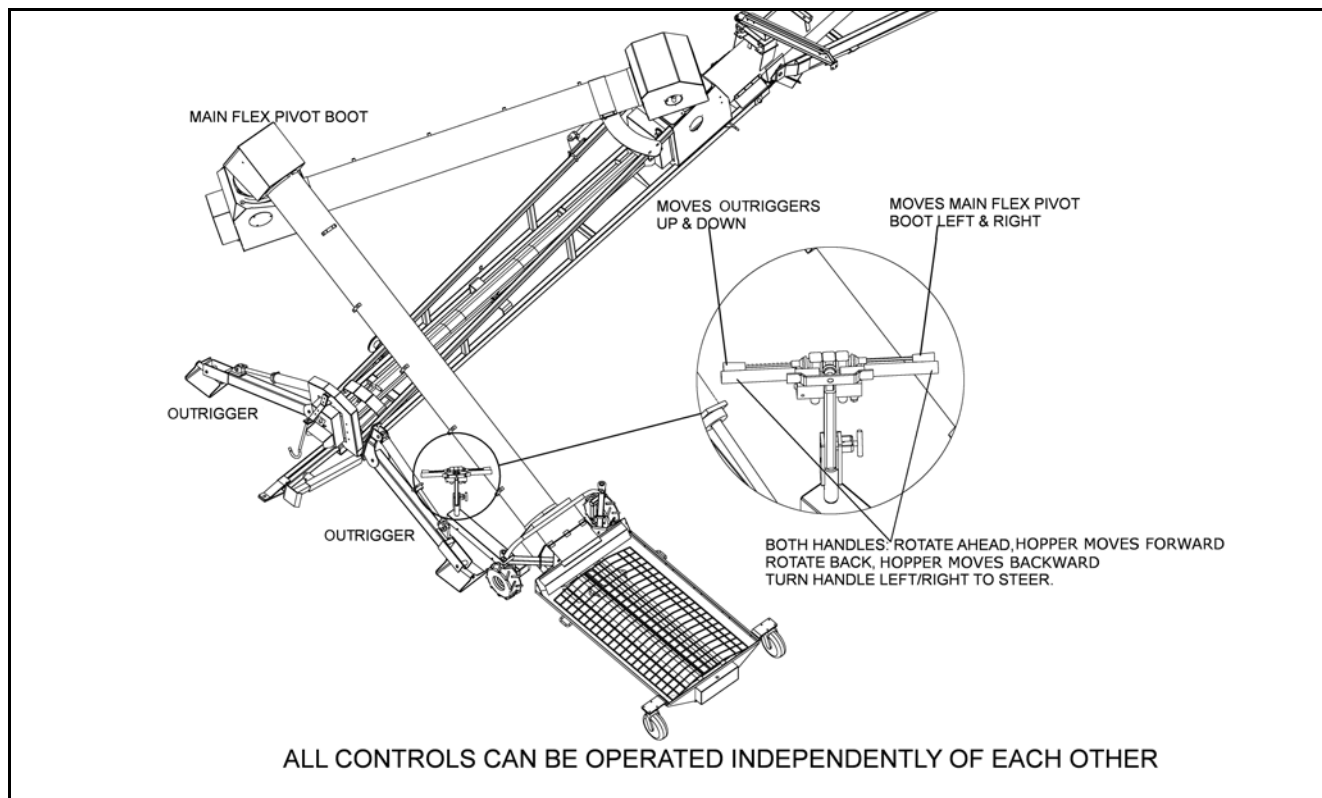

Figure 5.1

5.3.1. BEFORE STARTING

1. Ensure auger is properly placed (see Placement) and complete the pre-operational checklist.

Important: *Do not operate auger with intake hopper in transport position. This will damage the u-joint.*

2. If everything is satisfactory, prepare for 30 minutes of operation at half speed.
3. Using the hydraulic controls, position the intake hopper as shown in Figure 5.1.

5.3.2. OPERATION AND BREAK-IN INSTRUCTIONS

Important: *When starting auger for the first time, be prepared for an emergency shutdown in case of excessive vibration or noise. Auger may run rough until tube is polished.*

1. Roughly position the truck trailer centered at the intake hopper and use the hydraulic controls to position the hopper under the truck hopper.
2. Start tractor and idle at low rpm. Slowly engage PTO drive.

NOTICE

Running auger empty at high speeds results in excessive wear. Do not exceed 540 rpm.

3. Gradually begin feeding grain into hopper, bringing auger speed up to about 300 rpm.

Note: *Do not overfeed the hopper on initial loads; keep feed of grain at about half capacity.*

4. Once one truck hopper is empty, use the hydraulic controls to move the hopper under the remaining hopper and continue unloading truck.

DANGER	
	<p>Rotating Flighting Hazard!</p> <p>To prevent death or serious injury:</p> <ul style="list-style-type: none">• Keep away from rotating auger flighting.• Do not remove or modify auger flighting guards, doors, or covers. Keep in good working order. Have replaced if damaged.• Do not operate the auger without all guards, doors, and covers in place.• Never touch the auger flighting. Use a stick or other tool to remove an obstruction or clean out.• Shut off and lock out power to adjust, service, or clean.

- Monitor the auger during operation for abnormal noises or vibrations.
- **If grain overflows** through safety discharge door, then the auger is loaded beyond its capacity; reduce volume of feed going into intake hopper. Remember, auger capacity will decrease as the auger's angle increases.

NOTICE
<p>USE OF GRAIN SPREADERS: Many grain spreaders cannot handle the large capacity of some augers. Some augers plug, causing damage to the flighting and other drive components. This type of damage is not covered by warranty. Hints on how to avoid this...</p> <ul style="list-style-type: none">• Get a larger spreader, if available.• Remove the spreader.• Make sure spreader is turned on.• Center auger spout on spreader.• Do not lower auger spout into spreader.• Suspend the spreader from bin ceiling leaving extra room for excess grain to flow over the spreader. <p>BIN LEVEL INDICATORS: These augers are fast and bins fill up quickly. A full bin will cause auger to plug, which can damage the flighting and other drive components. Installing quality grain-level indicators on your bins will allow you to monitor bin filling and help prevent damage to your auger.</p>

5.3.3. AFTER OPERATING 30 MINUTES

1. After auger tube is polished and runs fairly smoothly, proceed to unload at full speed of 540 rpm.
2. After initial run, slow auger down until empty of grain and then stop.
3. Lock out tractor and conduct a complete inspection of auger following the checklist (see "Pre-Operational Checklist" on page 87).

5.3.4. AFTER OPERATING FOR 5 AND 10 HOURS

After initial start-up and inspection, auger should be operated and inspected at least 3 more times during the first 10 hours of operation.

After Break-in:

Maintain auger speed of 300 to 540 rpm under normal use for maximum efficiency and to reduce chance of plugging.

5.3.5. SHUTDOWN

1. Near the end of a load, decrease auger speed until all grain is clear of machine.
2. When auger is clear of grain, disengage PTO drive.
3. Shut down and lock out tractor.

5.3.6. EMERGENCY SHUTDOWN

1. Lock out tractor before correcting the problem.
 - a. Shut off tractor's engine and remove key or coil wire from tractor.
 - b. If removing key is impossible, remove PTO driveline from tractor.
2. If the problem is plugging, clear as much of the grain as possible using a piece of wood, wet/dry vac, or other tool before restarting auger.

Important: *Do not reach in and use your hands.*

5.3.7. FULL-TUBE RESTART

1. If cleanout covers or safety doors have been opened or removed, close or replace them before restarting the unit.
2. If auger is full of grain, do not restart at full speed. Engage PTO at low rpm, gradually increasing power until normal operating speed is reached.

NOTICE

Starting the auger under load may result in damage to unit.
Be sure there is no blockage.

5.4. LOWERING AUGER

After operation, move auger to next work/storage area and clean out.

1. Clean entire work area and clear area beneath auger.
2. Disconnect PTO driveline from tractor.
3. Place the upper flex tube in transport position, lock in place with saddle pin on flex frame (see Figure 5.1).
4. Use winch on side of auger to raise intake feed hopper slightly.

Note: *Reconnect lift cylinder hose coupler to tractor, if disconnected.*

5. Remove all supports and chocks.
6. Raise outriggers by first opening the ball valve located on outrigger leg and then engaging flex auger hydraulics (see Figure 5.1). Put locks in place and insert retaining pins (Figure 5.2).
7. Move auger out of working position and lower fully by opening hose valve and tractor valve, feathering to prevent too rapid a descent.
8. Once valves are open, auger lowers by gravity. As the auger nears the full down position, the rate of descent increases. Do not operate with tractor valve fully open.
9. Lower auger using tractor hydraulics, seating lift assist arm against the track and the track shoe against the trackstop with slight tension on the lift.
10. Place the steering assembly in transport position. Pull out the lockpin, and fold the steering assembly down 90°.

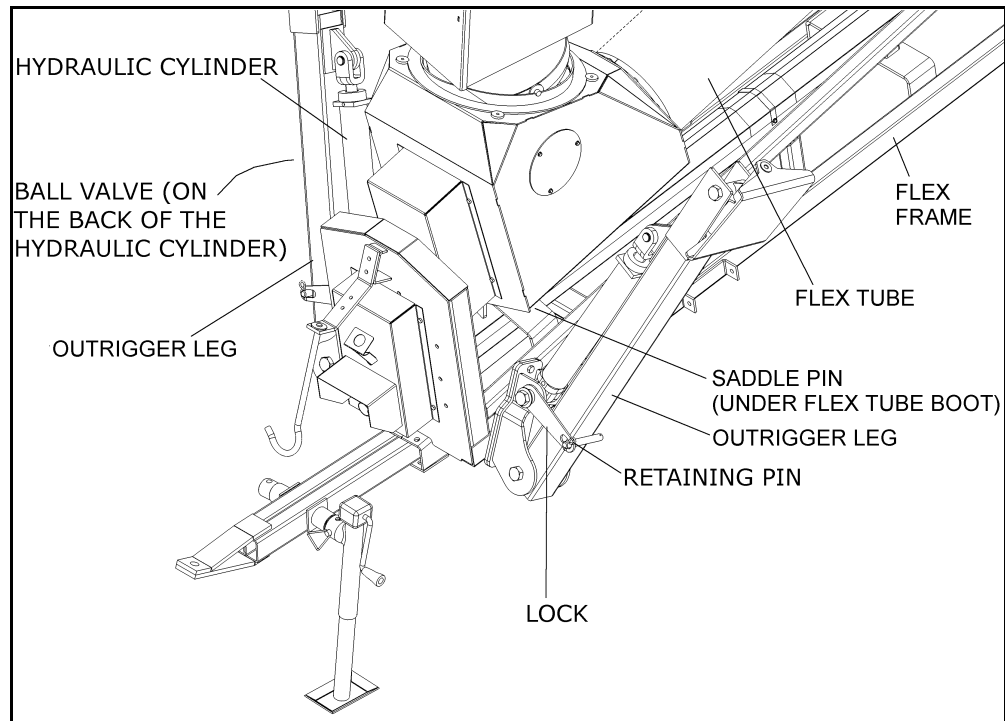

Figure 5.2

11. Attach cable hook to the loops inside the hopper (Figure 5.3).
12. Fully raise hopper with intake side facing towards the main auger as shown in Figure 5.3.
13. Secure hopper to lift arm with hopper lock, saddle pins, and hairpins provided.

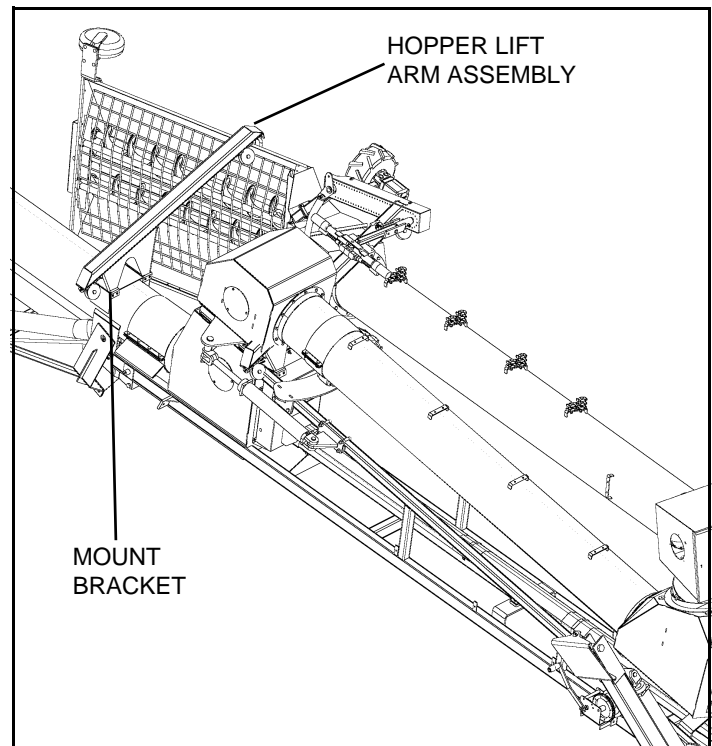

Figure 5.3

Important: *Never operate auger with intake feed hopper in transport position. This will damage the universal joint.*

14. Clean out auger.
 - a. Shut off tractor engine and lock out power.
 - b. If necessary, open cleanout cover on the boot and manually clean out grain with a piece of wood, vacuum cleaner, or other tool. Do not use hands.
 - c. Replace cleanout cover.
 - d. Clean out remaining grain using a piece of wood or other tool.
15. Prepare for transport and placement or storage (see appropriate chapters for more information).

6. Maintenance & Storage

WARNING

Before continuing, please reread the safety information relevant to this section at the beginning of this manual. Failure to follow the safety instructions can result in serious injury, death, or property damage.

6.1. GENERAL MAINTENANCE PROCEDURES

Please follow the guidelines below.

Area	Maintenance Procedures	Frequency
General	While auger is in use, observe the pre-operational checklist.	Daily
General	Check all operating, lifting, and transport components. Replace damaged or worn parts before using auger. <ul style="list-style-type: none"> For replacement instructions, see "Assembly" on page 19. 	Regularly
Hydraulic Hose	Using cardboard as a backdrop, check hose and hose coupler for leaks, wear, and damage. Replace if necessary. Refer to the Hydraulic Safety section. <ul style="list-style-type: none"> Replacement hose and hose ends must have a minimum strength of 2750 psi (18,961 kPa) working pressure. 	Frequently
Lift Cable	Check and replace if frayed or damaged. Make sure cable clamps are secure.	Periodically
Cable Sheaves	Oil sheave pins on lift cylinder.	Twice/year
Truss Cables	Adjust to keep auger tube reasonably straight.	As necessary
Wheel Hubs	Repack with lithium-based grease.	Every 2–3 years
Tire Pressure	Check with a pressure gauge. Pressure should be maintained according to sidewall recommendations.	Monthly, or if it seems low
Hopper Lift Cable	Check and replace if frayed or damaged.	Periodically
Hopper Lift Cable Pulleys	Oil lightly for easier raising of hopper.	Several times a year

Area	Maintenance Procedures	Frequency
Winch	Keep a film of grease on gears.	Regularly
	Oil the bushings, drum shaft, and ratchet. <ul style="list-style-type: none"> Take care not to get oil or grease on brake discs. Service winch with auger in fully lowered position and cable slack. 	Occasionally
	Replace brake discs if less than 1/16" thick.	As required
	Service winch with auger in fully lowered position and cable slack.	Regularly
PTO Driveline	Lubricate all 5 grease fittings with good quality Lithium Soap Base E.P. Grease meeting NLGI #2 specifications and containing no more than 1% molybdenum disulfide (example: Shell Super Duty). <ul style="list-style-type: none"> Grease fittings No. 2 and 3 can be reached through hole in implement end portion of the driveline guard. Grease fitting No. 4 can be reached through hole in center portion of the driveline guard. The first lube interval should be 16-24 hours of operation after initial start-up, then follow the schedule. 	After the first 16–24 hours and then regularly afterward
General	Ensure that the set screws and shear-bolt are tight.	Regularly
Low Profile Hopper	Loosen the 2 nuts securing the service door. Open door, then grease the 4 bushings and the 2 u-joints. Close door, then securely tighten the two 3/8" nuts.	Frequently
	Check and adjust the hopper drive chain and lubricate the hopper drive chain. <ul style="list-style-type: none"> To adjust chain, loosen the bearing bolts and adjust chain tension to about 1/4" deflection. Replace guard. 	Occasionally

LUBE RECOMMENDATIONS ^a		
INTERVAL	LOCATION	AMOUNT
8 HRS.**	CROSS & BEARING ON PTO	1 PUMP
8 HRS.	TELESCOPING MEMBERS ON PTO	4-8 PUMPS
8 HRS.**	CV BALL & SOCKET ON PTO	1-2 PUMPS
8 HRS.	DOWNRIGGER LEG	1-2 PUMPS
8 HRS.	BOOT UNDER HYD CONTROLLED SWING	4-8 PUMPS

a. **Constant angle applications must have lube interval of 4 hours.

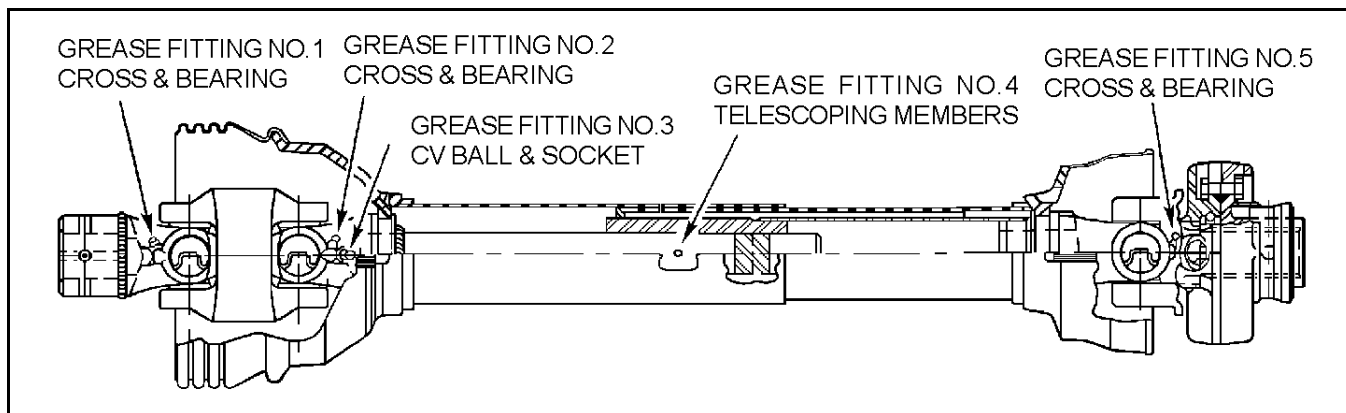

MECHANICAL DRIVE SYSTEM:

Area	Maintenance Procedures	Frequency
Chain Drives <ul style="list-style-type: none"> Replace sprocket guard after maintenance! 	Keep drive chain tension adjusted to about 1/4" deflection by loosening the four bolts on lower bearing, then re-tighten.	Regularly
	Oil chain often enough to keep film of oil on it (this can be done through the hole in the side of the sprocket guard).	Frequently
Universal Joint	Flip up safety discharge door and lubricate grease fitting in the u-joint. Check set screws and re-tighten if necessary. To open the other door, remove the 3 screws.	After every 8 hours of operation
	Check set screws and re-tighten if necessary.	Regularly
Gearboxes	Flip up safety discharge door or open round service door and service each of the four gearboxes.	At least once a year, depending on use
	For more extensive servicing or repairs, remove hopper from boot assembly by removing the 3/8" x 3/4" bolts and large washers. Lift hopper with front-end loader or other secure method (Figure 6.1).	As required
	Check and re-tighten set screws and connecting bolts. Clean and lightly grease the splined shaft. Reattach hopper to boot assembly as per instructions. (See Low Profile Hopper section.)	As required

WARNING	
	<p>Do not operate auger without intake hopper in place.</p> <p>Replace and secure service doors before operating auger.</p>

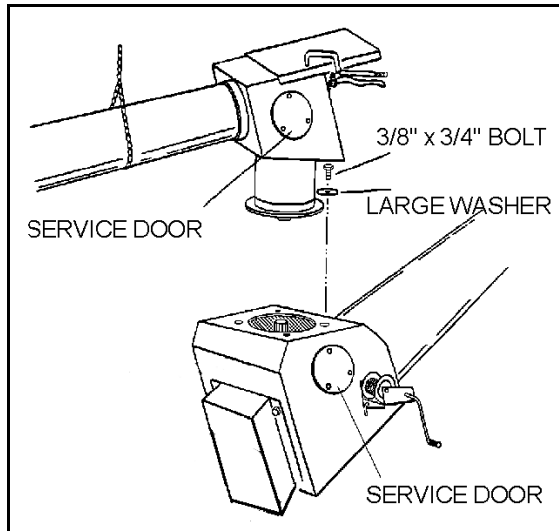



Figure 6.1

6.2. STORAGE

TO PROTECT AUGER IN STORAGE DURING THE OFF-SEASON:

1. Lower the auger to full down position with slight tension on the cable (see Operation for instructions on lowering).
2. Lubricate all grease fittings according to the maintenance procedure.
3. Inspect auger for damage and note any repairs required. Order replacement parts from your dealer.

WARNING	
	Support discharge end of auger before removing or replacing any parts on the undercarriage.

4. Check tire pressure and inflate if necessary. See sidewall for recommended pressure.
5. Clean and re-lubricate spline on PTO driveline. Cover PTO driveline with a plastic bag to protect it from the weather and place it in transport saddle.
6. Tow auger to storage area. Park and chock wheels.

TO PREPARE AUGER FOR USE AFTER STORAGE:

1. Check tire pressure and inflate if necessary. See sidewall for recommended pressure.
2. Tow auger to work site.
3. Remove cover from spline of PTO driveline and re-lubricate.

4. Check oil level in gearbox and refill if necessary (half full only).
5. Replace any damaged parts and decals.
6. Check and perform general maintenance before using auger.
7. Before raising auger after storage, make certain cable is in good condition, replacing it if frayed or damaged. Also make sure cable is properly seated in roller track and that cable clamps are secure.

7. Troubleshooting

Problem	Possible Cause	Remedy
<p>Excessive noise or vibration.</p> <p>*Remember to follow proper break-in procedures—auger may run rough until tube is polished. If noise is extreme from outset or continues after several loads of grain are fed, continue with troubleshooting below.</p>	<p>Determine if noise originates in main or swing away section of auger. Disconnecting the chain from the sprocket drive can assist in narrowing down the source of the problem. If noise <i>disappears</i> when chain is disconnected, problem is likely in the swing away auger.</p>	
	<p>Hopper flight support bearings are dry or have failed.</p>	<p>Check for flight operation by rotating by hand with sprocket chain disconnected and tractor shut off. Grease or replace as necessary.</p>
	<p>Universal joint not greased or is faulty.</p>	<p>Grease or replace as necessary.</p>
	<p>Faulty upper gearbox.</p>	<p>Refer to appropriate troubleshooting section.</p>
	<p>Obstruction in tube.</p>	<p>Visually inspect for cloth or trash wrapped around flighting, or a buildup from oily crops.</p>
	<p>Bent flight stub on swing flighting.</p>	<p>Remove flighting and roll against flat surface to determine if stub is true.</p>
	<p>If noise <i>continues</i> when chain is disconnected, check auger or PTO.</p>	
	<p>CV PTO failure.</p>	<p>Refer to appropriate troubleshooting section.</p>
	<p>Incorrectly adjusted truss cables.</p>	<p>Support end of auger and adjust cables so auger is flat or slightly curved upwards.</p>
	<p>Flighting has peeled back due to plugging.</p>	<p>Inspect spout end of auger for flight condition. Remove and replace flight sections as necessary.</p>
	<p>Faulty lower gearbox.</p>	<p>Refer to appropriate troubleshooting section.</p>
	<p>Lower bearing dry or has failed.</p>	<p>Refer to appropriate troubleshooting section.</p>
	<p>Bent flighting section.</p>	<p>Support auger and remove all flight sections. Check for straightness of flight stubs by rolling across flat section of concrete floor. Straighten stub or replace as necessary. Take care not to bend flighting when reinstalling.</p>
	<p>Obstruction in tube.</p>	<p>Visually inspect for cloth or trash wrapped around flighting, or a buildup of gum from oily crops such as flax or canola.</p>
<p>High spot at flighting joints.</p>	<p>Check with straight edge. If necessary, grind down until even.</p>	

Problem	Possible Cause	Remedy
CV PTO failure.	Try to determine the operation and maintenance habits of the owner in order to avoid multiple repairs and unnecessary frustration.	
	Broken CV ball.	Most frequently occur when PTO driveline is not disconnected during transport or setup of the auger. Remind all operators to disconnect PTO driveline except when at the bin in operation.
	Excessive PTO angle.	Check manual for correct dimensions (auger input and tractor PTO output). It may be necessary to raise tractor drawbar to maintain correct dimensions. Extreme side-to-side angles that are necessary because of the bin and tractor placement may be corrected with a right angle drive kit.
	Early series cross-link or non-Westfield part used.	Ensure new "E" series cross links and genuine Westfield replacement parts are used.
	Telescoping part of PTO shaft bottoming out.	Pull out or lengthen tractor drawbar to maintain minimum clearance.
Bearings not receiving adequate grease.	Check manual—CV PTO drivelines should be greased as part of daily maintenance procedures.	
Premature gearbox failure.	While all gearboxes come from the factory filled with oil, it should be part of the setup procedure to double check that a half full level is maintained.	
	Failed seal.	Check gearbox levels on a regular basis and only fill with EP90 oil.
	1000 rpm tractor input being used.	Use 540 rpm tractor or install speed reducer.
Shear bolts fail repeatedly.	Incorrect shear bolt type.	Replace with correct part number. Westfield shear bolts are specifically designed to provide correct driveline protection.
	Shear bolt hole worn out-of-round.	Frequent use of an incorrect shear bolt size can wear the mounting hole creating a "scissor effect," which will require replacement of the affected parts.
	Corn spreaders in bin unable to keep up with auger output.	Slow down auger or remove corn spreaders.
	Flighting "peeled back" as a result of plugging.	Occurs when bin has overfilled or corn spreaders restrict end of discharge. Inspect flighting at discharge end. If necessary, replace flighting.
	Driveline failures (bearing, gearbox, etc.).	Refer to appropriate troubleshooting section.

Problem	Possible Cause	Remedy
Lower bearings repeatedly fail.	Bearings not receiving adequate grease.	Check manual for correct greasing intervals.
	Bearing load not evenly distributed between upper and lower bearings.	Use correct sequence of tightening lock collars when setting up or replacing bearings. Adjust bearing load using threaded upper flight stub.
	Insufficient CV PTO shaft clearance.	Maintain correct tractor hitch dimensions as per manual.
	Failure of bearing seals.	Wet grain or fertilizer will damage seals if left in boot over time. Clean out boot before storing auger.
	Bent lower flight stub.	Check for straightness of flight stub by rolling across flat concrete section. Straighten stub or replace as necessary.
Premature wear on auger tubes.	Auger being run at low capacity or empty for extended periods of time.	Frequently occurs on farms using grain wagons. Auger should no be left unattended when filling bins. Depending on application, a belt conveyor may be more appropriate.
	Bent flighting.	Refer to appropriate troubleshooting section.
	Flighting allowed to wear beyond normal point of replacement.	When flighting becomes razor-thin at intake, replacement is critical. Since flight material is double thickness at welded lap joints, high spots on flight occur and can accelerate spot tube wear.
Hydraulic lift settles out over time.	Shut off ball valve is open.	Oil is leaking through tractor valve. Auger ball valve should be closed whenever set up at a bin.
	Shut off ball valve is leaking.	Disconnect hose from tractor and check for leakage.
	Lift cylinder cup seal leaking or cylinder barrel scored or pitted.	See if oil leaks from cylinder breather hole (single action cylinders). Remove and replace cup seal and hone cylinder or replace as needed.
Hydraulic controlled tube doesn't swing in or out.	Transport lock pin engaged.	Disengage pin.
No minimal hydraulics function.	Hydraulic flow going to valve in wrong direction.	Reverse tractor hydraulics or move hydraulic lever opposite.
Hydraulic control tube hits transport rest plate, won't roll on smoothly.	Mis-adjusted roller.	Adjust height. Adjust roller.

8. Appendix

8.1. SPECIFICATIONS

Important: *Westfield Industries reserves the right to change specifications without notice.*

Table 8.1

		71'	81'	91'	111'
CAPACITY					
Unloading Rate		8700 - 9600 Bu/Hr			
DIMENSIONS					
Tube Size		13"	13"	13"	13"
Height Lowered (A)		12'0"	10'7"	12'6"	15'0"
Height Halfway (B)		32'2"	31'5"	36'0"	42'6"
Height Raised (C)		46'0"	51'9"	59'6"	71'6"
Reach Lowered (D)		33'7"	41'3"	44'8"	54'7"
Reach Halfway (E)		30'9"	38'7"	41'5"	50'11"
Reach Raised (F)		27'2"	32'0"	34'8"	42'6"
Height at Arms (G)		20'2"	22'4"	23'3"	27'8"
Height at Wheels (H)		25'7"	27'2"	28'6"	33'5"
Reach to Arms (I)		27'7"	26'6"	31'4"	38'5"
Reach to Wheels (J)		27'9"	30'8"	38'4"	48'9"
Width (transport)		10'4"	9'4"	14'8"	15'4"
Width (with axles extended)		--	12'4"	17'8"	18'4"
TIRES					
Type		11-15X8PLY			
Hubs		6 Bolt Automotive Type			
WEIGHT					
Weight (lb)	Total Weight	6675	7480	7930	9380
	Axle Weight	4175	4980	5430	7100
	Hitch Weight	2500	2500	2500	2280
PTO DRIVE					
Power Requirements		100 HP	120 HP	140 HP	160 HP
PTO Speed		540 rpm			
PTO Shaft		35R			
OTHER					
Hitch Jack		5000 lb Side Winder			

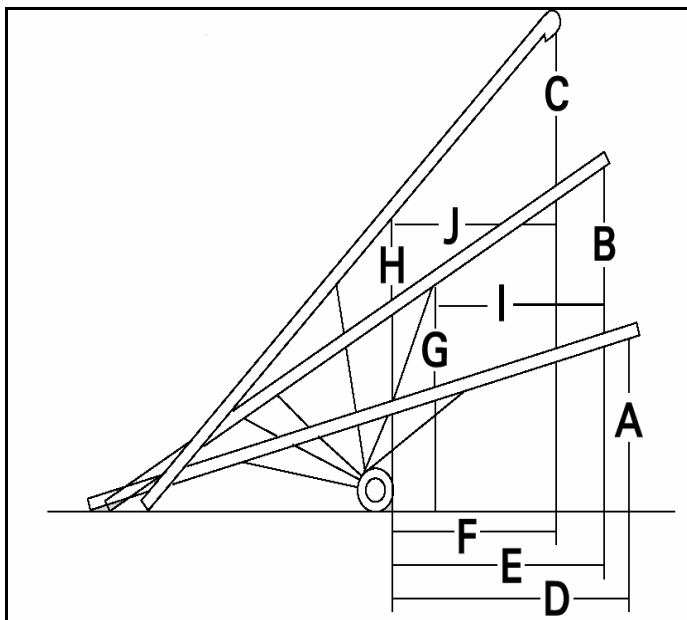

Figure 8.1

8.2. LIFT CYLINDER HYDRAULICS (81'/91'/111')

The 81'/91'/111' auger is elevated with 2, specially designed, double-acting hydraulic cylinders and cables. The following table lists the psi required to raise specific auger sizes (as determined by testing).

These tests used a hydraulic pressure gauge (4000 psi maximum rating) and are solely intended to be used as a guide. The psi requirements for specific augers may vary slightly. Should your auger require a significantly higher psi to raise, contact either your dealer or Westfield Industries.

SIZE	PSI	kPa
81'	1500	10,343
91'	1950	13,443
111'	2000	13,790

The approximate quantity of hydraulic fluid required to raise auger is 4 liters.

HOW TO CHARGE THE LIFT SYSTEM

The cylinders will require approximately 19 L (5 US gallons). Check your tractor's operation manual for correct oil type and specifications.

Before charging cylinders, ensure that:

- Tractor is correctly hooked up.
- Hydraulic hoses are connected.
- Shut-off valve is open.

- Auger is parked on level ground.

Note: *Do not raise auger in high winds.*

1. Start with the tractor's hydraulic oil level in a normal operating range.
2. Add about **4 L** (1 US gallon) to the tractor's hydraulic oil reservoir.
3. Start tractor, then raise auger until the lift-assist is fully extended and track shoe has moved about 1' from trackstop.
4. **With tractor still running**, lower auger to full down position.
5. Repeat steps 2, 3, and 4 until about 19 L (5 US gallons) have been added and tractor hydraulic oil level in the reservoir remains within the operating range.

8.2.1. SPECIAL NOTES

Do not exceed a constant back pressure of 300 psi (2068 kPa) in the hydraulic motor.

- The hydraulic system on some tractors is designed so that the return flow of hydraulic fluid from the hydraulic motor to the tractor is restricted. This creates excessive back pressure inside the hydraulic motor and deprives it of an adequate flow of hydraulic fluid. The result will be **seal failure, overheating, rough running, and loss of power.**

To date, these problems occur primarily with certain John Deere tractors. Kits to correct the problem are available from your John Deere dealer (Figure 8.2).

Important: *John Deere Series 50 tractors with a single hydraulic lever will require this kit. Series 50 tractors with double hydraulic levers have the kit pre-installed.*

Note: *The problem discussed in this section may exist on tractors other than the John Deere. Should you experience this situation, contact your tractor dealer.*

A remote cylinder control valve oil return kit, which returns oil to the oil filter cover, is available for more efficient use of tractor hydraulics. Order AR71945 Remote Cylinder Control Valve Oil Return kit and AT30197 Ported Cover for transmission filter. (See Figure No. 38)

IMPORTANT

A steel-encased filter element must be used with the AT30197 Ported Filter Cover.

W8058

INFORMATION COURTESY JOHN DEERE MANUAL "PREPARING THE TRACTOR."

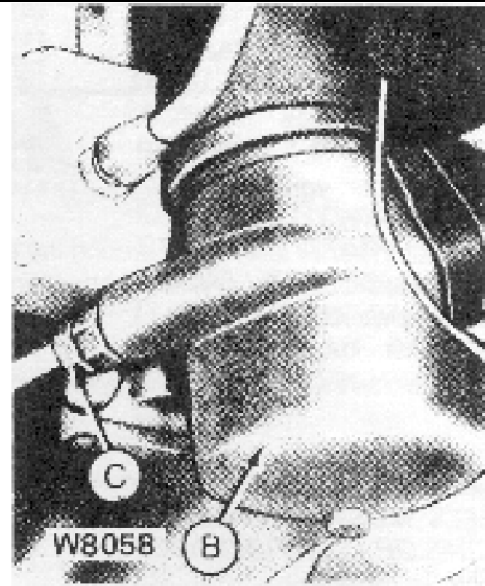

Figure 8.2

WARRANTY

Westfield Industries Ltd. warrants products of its manufacture against defects in materials or workmanship under normal and reasonable use for a period of one year after date of delivery to the original purchaser.

Our obligation under this warranty is limited to repairing, replacing, or refunding defective part or parts which shall be returned to a distributor or a dealer of our Company, or to our factory, with transportation charges prepaid. This warranty does not obligate Westfield Industries Ltd. to bear the cost of labor in replacing defective parts. Any defects must be reported to the Company before the end of the one year period.

This warranty shall not apply to equipment which has been altered, improperly assembled, improperly maintained, or improperly repaired so as to adversely affect its performance. Westfield Industries Ltd. makes no express warranty of any character with respect to parts not of its manufacture.

The foregoing is in lieu of all other warranties, expressed or implied, including any warranties that extend beyond the description of the product, and the IMPLIED WARRANTY of MERCHANTABILITY is expressly excluded.

WESTFIELD INDUSTRIES LTD.

ROSENORT, MANITOBA

CANADA

ROG 1WO

WESTFIELD[®]

Westfield is a Division of Ag Growth Industries LP

Part of the Ag Growth International Inc. Group

P.O. Box 39

Rosenort, Manitoba, Canada R0G 1W0

Phone: (866) 467-7207 (Canada & USA)

Fax: (866) 768-4852

website: www.grainaugers.com

email: sales@grainaugers.com

Printed in Canada